

Linear Array Probe

EUP-L73S

INSTRUCTION MANUAL

Notes for operators and responsible maintenance personnel

- ★ Please read through this Instruction Manual carefully prior to use.
- ★ Keep this Instruction Manual together with the system with care to make it available anytime.

 **Hitachi, Ltd.**

Tokyo , Japan

Q1E-EP1019-9

© Hitachi, Ltd. 2013,2017. All rights reserved.

 0123

Manufacturer:



Hitachi,Ltd

2-16-1, Higashi-Ueno, Taito-ku, Tokyo,

110-0015, Japan

+81-3-6284-3668

<http://www.hitachi.com/businesses/healthcare/index.html>

European

Representative:



Hitachi Medical Systems GmbH

Otto-von-Guericke-Ring 3 D-65205 Wiesbaden,

Germany

EU Importer:

Address:

Hitachi Medical Systems Europe Holding AG

Sumpfstrasse 13 CH-6300 Zug, Switzerland

Local Distributor:

About this manual

This instruction manual shall provide instructions for using, cleaning, and disinfecting and/or sterilizing the HITACHI ultrasound probes. It also describes safety considerations, maintenance.

For instructions about operating the main unit, refer to the operation manual for it.

Before using the probe, thoroughly read this manual and keep this book for future reference.

If you have any questions concerning the manual, please contact a service support.

The following conventions are used throughout the manual to denote information of special emphasis.



WARNING: "Warning" is used to indicate the presence of a hazard which can cause severe personal injury, death, or substantial property damage if the warning is ignored.

CAUTION: "Caution" is used to indicate the presence of a hazard which will or can cause minor personal injury or property damage if the caution is ignored.

NOTICE: "Notice" is used to notify people of installation, operation, or maintenance information which is important, but not hazard related.









Graphical Symbols for Use in Labeling of Hitachi Ultrasound Probes

Some graphical symbols that are used in labeling of Hitachi Ultrasound Probes are compliant with EN980:2008 standard. Refer to the following table about the meanings of them.

Explanation of Symbol	Symbol	Descriptive Content
Manufacturer Company Name and Address		Hitachi, Ltd. 2-16-1, Higashi-Ueno, Taito-ku, Tokyo, 110-0015, Japan +81-3-6284-3668 http://www.hitachi.com/businesses/healthcare/index.html
Authorized Representative in The European Community		Hitachi Medical Systems GmbH Otto-von-Guericke-Ring 3 D-65205 Wiesbaden, Germany
Keep away from Sunlight		Store the probe in a cool place and keep away from high temperature, high humidity and direct sunlight.

Definition of symbol

The following symbol is also used for HITACHI Ultrasound Probes.

Location	Symbol	Definition
Probe connector		This instrument complies with Directive 93/42/EEC relating to Medical Device and Directive 2011/65/EU relating to RoHS
Probe connector	IPX7	IPX7 mark See section 1.6.
Probe connector		Type BF APPLIED PART
Probe connector		General warning sign
Probe connector		Warning; dangerous voltage
Probe connector		Caution; Biohazard
Probe connector		Follow the instruction manual to operate this instrument. If not avoided, may result in injury, property damage, or the equipment trouble.
Probe connector		STERRAD sterilization compatibility mark
Probe connector		Upper Limit of Temperature; The probes that are <u>applicable</u> to Ethylene Oxide Gas Sterilization use symbol of "Upper Limit of Temperature: 55 degrees".
Probe connector		Do not waste the instrument as general waste. Comply with a local regulation.
Probe connector	Rx Only	By prescription only. U.S. Federal Law restricts this device to sale on order of a physician only.

CONTENTS

Page

1. Introduction	1
1.1 General	1
1.2 Principles of operation	1
1.3 Intended Use	2
1.4 Components	2
1.5 Option	2
1.6 External View	3
2. Inspection before Use	4
2.1 Inspection for Appropriate Connection	4
2.2 Inspection for Material Surface	4
3. Operation Procedure	5
4. Magnetic Sensor for EUP-L73S	7
4.1 Magnetic sensor EZU-RV2S	7
4.2 Magnetic sensor EZU-RV3S	10
4.3 Elasto Coupler	13
5. Reprocessing Procedure	14
5.1 Point of use (Pre-cleaning)	17
5.2 Containment and transportation	17
5.3 Manual Cleaning and disinfection	17
5.4 Drying	21
5.5 Inspection	21
5.6 Packaging	21
5.7 Sterilization	21
5.8 Storage	23
6. Maintenance and Safety Inspection	24
7. Safety Precautions	25
8. Specifications	26
8.1 Probe	26
8.2 Suppliers List	27
9. Disposal of the probe	28

1. Introduction

1.1 General

The EUP-L73S is a linear array probe.

The acoustic output of the EUP-L73S was measured according to the IEC60601-2-37 standard and the measurement was conducted by operating with the Hitachi ultrasound diagnostic scanner. The measured acoustic output is listed in the instruction manual of the Hitachi ultrasound diagnostic scanner.

The EUP-L73S is categorized in class IIa according to Directive 93/42/EEC and classified as type BF according to IEC 60601-1.

1.2 Principles of operation

This probe and the ultrasound diagnostic scanner enable image diagnosis using ultrasonic waves. This system operates under the principles described below.

- 1) When an electric pulse signal is applied from the transmitter to the transducer of the probe, the transducer converts electric signals into mechanical vibration energy for emitting pulse-shaped ultrasonic waves into the body part, liquid or other medium contacting the transducer.
- 2) The emitted ultrasonic waves are reflected by boundaries with different acoustic characteristics (acoustic impedance) within the body.
- 3) The transducer is also used to receive reflected ultrasonic waves. The transducer vibrates mechanically due to the received ultrasonic waves and converts mechanical vibrations into electric energy. Electric signals are converted to shades of brightness by brightness modulation to obtain an image.

1.3 Intended Use

The EUP-L73S is designed for observation and diagnosis mainly of the following regions by connecting with the Hitachi ultrasound diagnostic scanner.

- Superficial region
- Cervical region
- Mammary gland
- Biopsy (with Coupler Attachment)

WARNING

Never use the probe for following applications.

- Direct contact to the heart.
- Biopsy to the heart.

1.4 Components

The components of the EUP-L73S are given below:

- 1) Probe EUP-L73S 1 piece
- 2) Instruction manual 1 copy

CAUTION

Sterilization has not been made to the probe, shipped from the factory. Prior to use the probe, be sure to clean, disinfect and sterilize the probe.

1.5 Option

- 1) Magnetic Sensor Attachment (part number: 7349172A)
- 2) Spacer for EZU-RV2S
- 3) Elasto Coupler (part number: 7225446A)
- 4) Coupler Attachment EZU-PA7L1

Please refer to the instruction manual of EZU-PA7L1 about the method of handling, cleaning and sterilizing the EZU-PA7L1.

CAUTION

Sterilization has not been made to the magnetic sensor attachment, the spacer for EZU-RV2S and the elasto coupler and the EZU-PA7L1 shipped from the factory. Prior to use of them, be sure to clean, disinfect and sterilize them.

1.6 External View

The external view of the EUP-L73S is shown in Fig. 1.

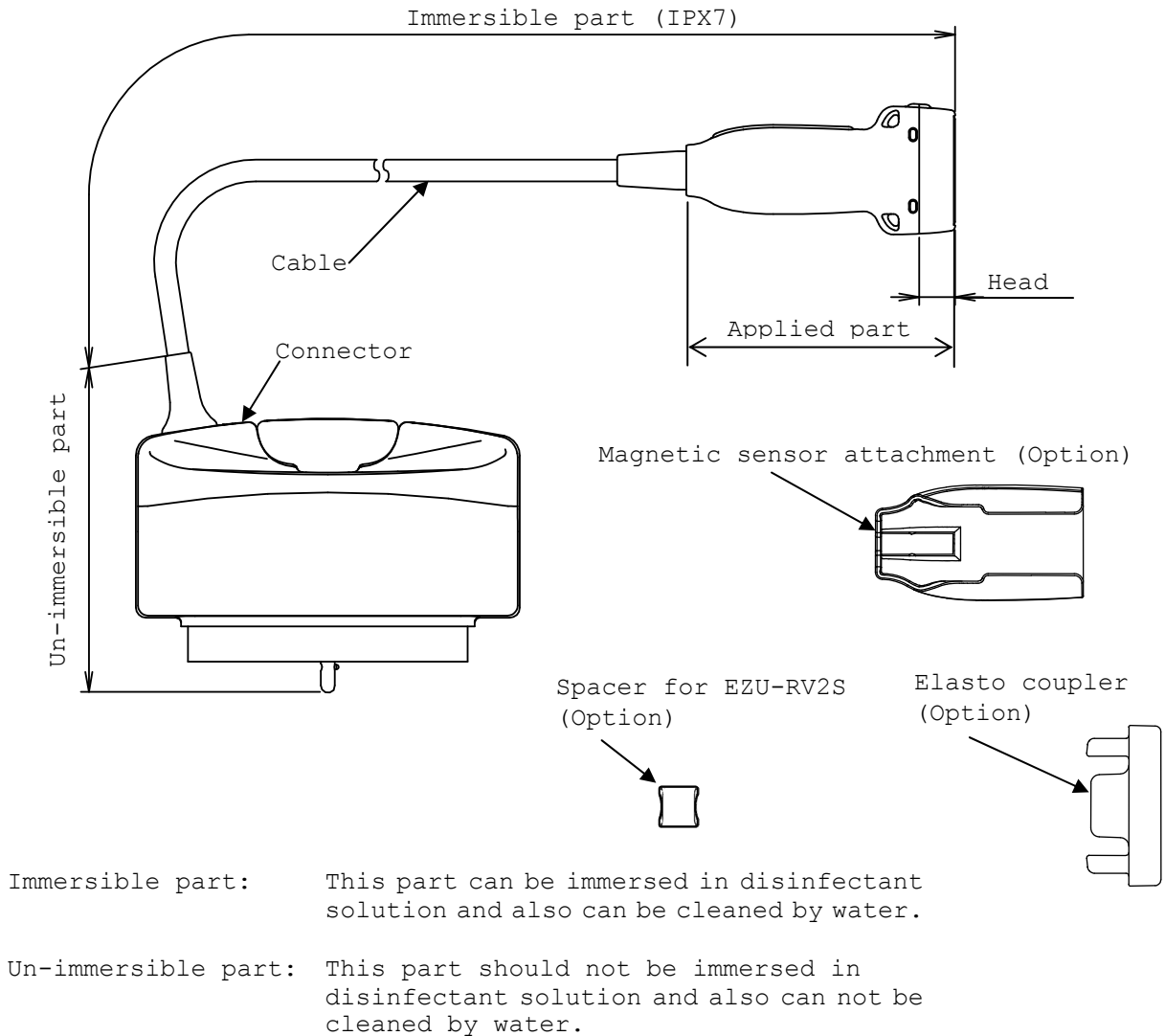

Fig. 1 External view of the EUP-L73S

2. Inspection before Use

Prior to use, the probe must be carefully inspected that it is appropriate for use.

2.1 Inspection of appropriate connection

2.1.1 Confirm that the system is correctly operating.

Refer to the instruction manual for the ultrasound diagnostic scanner.

2.1.2 Do not attach or connect unauthorized devices nor instruments on the probe, such as unauthorized biopsy attachments.

2.2 Inspection of material surface

2.2.1 Visually inspect that the surface of the probe and head, housing, the cable and the connector for any crack, scratch or denaturalization. If you find any damage, do not use the probe and contact a service support immediately.

2.2.2 Visually inspect the magnetic sensor attachment and the spacer for EZU-RV2S for any crack, deformation or denaturalization. If you find any damage, do not use them and contact a service support immediately.

2.2.3 Visually inspect the elasto coupler for any crack, deformation or denaturalization. If you find any damage, do not use the elasto coupler. If you find any damage, do not use the elasto coupler and contact a service support immediately.

3. Operation Procedure

- 1) Confirm that the probe, the magnetic sensor attachment, the spacer for EZU-RV2S and the elasto coupler are cleaned, disinfected and/or sterilized.
- 2) Connect the probe to the ultrasound diagnostic scanner, operate the scanner, and adjust the image, all according to the instructions given in the operation manual for the ultrasound diagnostic scanner with which the probe is used as connected.
- 3) Confirm the direction of the probe. The relationship between the direction of the probe and image is shown in Fig. 2. The Right-left orientation mark on the image indicates the direction of the index mark of the probe.

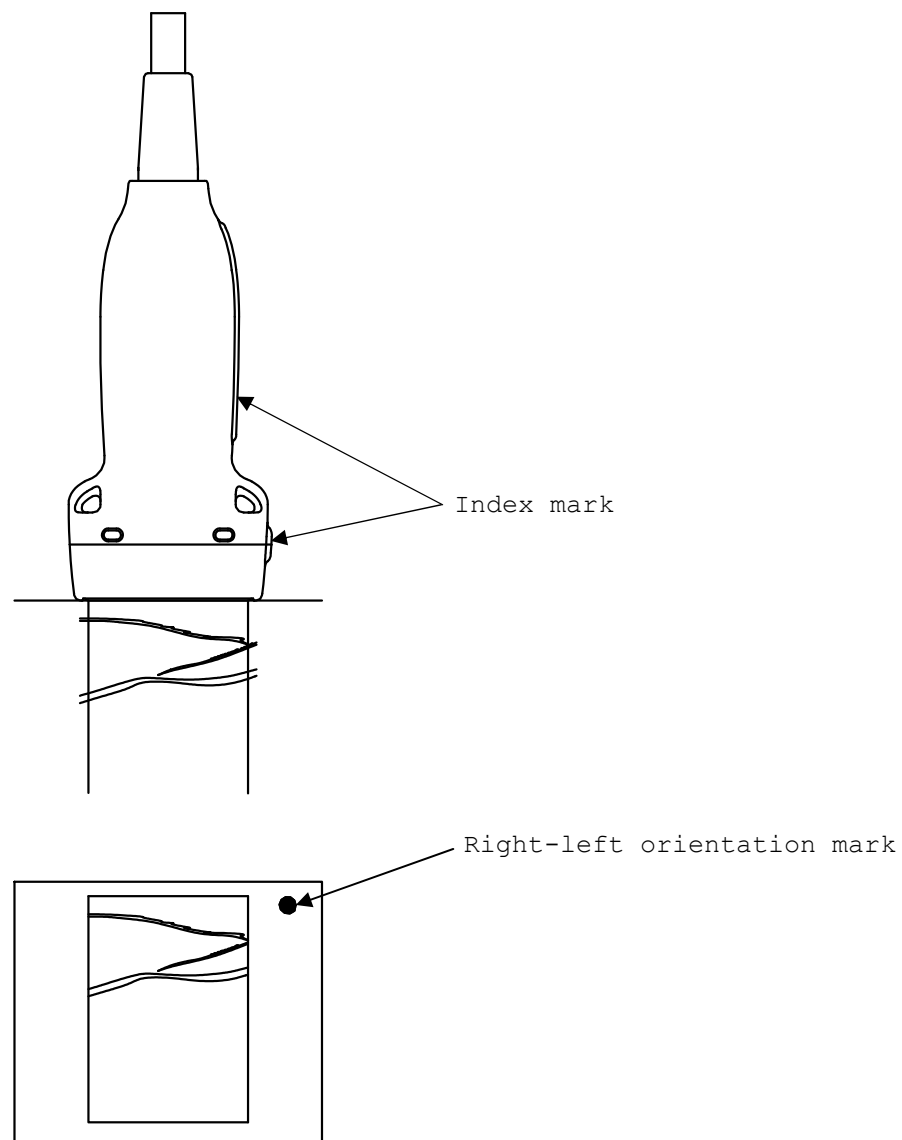

Fig. 2 Relationship between the direction of the probe and the Right-left orientation mark

- 4) Use a sterile probe cover to protect the probe.
The probe cover should be allergy free material to avoid allergic reaction. Between the probe and the probe cover, acoustic coupling gel is required as a couplant.
- 5) Place the probe on the examination site and adjust the probe's position for a clear view of the desired image.
- 6) After using the probe, the magnetic sensor attachment, the spacer for EZU-RV2S and the elasto coupler perform the reprocessing procedure in accordance with the procedure stated in **"5. Reprocessing procedure"** every time immediately after completing the ultrasound examination.
- 7) Store the probe, the magnetic sensor attachment, the spacer for EZU-RV2S and the elasto coupler in the environment indicated in **"6. Maintenance and Safety Inspection"**.

4. Magnetic Sensor for EUP-L73S

There are two types of magnetic sensors for EUP-L73S, the EZU-RV2S and the EZU-RV3S.

The magnetic sensors EZU-RV2S and EZU-RV3S are shown in Fig.3 and Fig.8.

The use of the EUP-L73S with either one of the magnetic sensors enables the user to perform RVS (Real-time Virtual Sonography).

4.1 Magnetic sensor EZU-RV2S

The magnetic sensor EZU-RV2S is shown in Fig. 3.

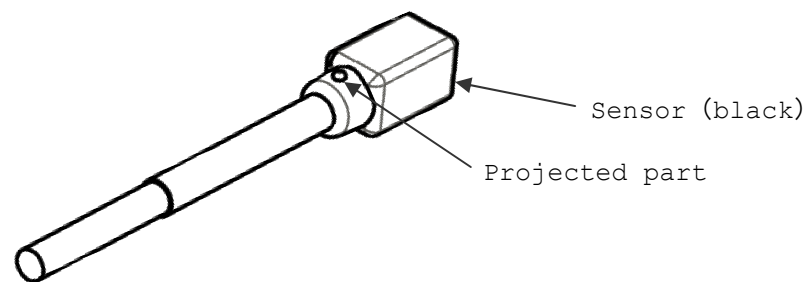

Fig. 3 Magnetic sensor EZU-RV2S

4.1.1 How to attach the Magnetic sensor

The procedure of attaching the magnetic sensor is as follows.

- 1) Attach the spacer for EZU-RV2S to the magnetic sensor.
- 2) Insert the magnetic sensor into the magnetic sensor attachment with the correct direction as shown in Fig. 4.
- 3) Place the magnetic sensor attachment on the probe as shown in Fig. 5. Fit the projected part of the magnetic sensor attachment in the index mark of the probe.

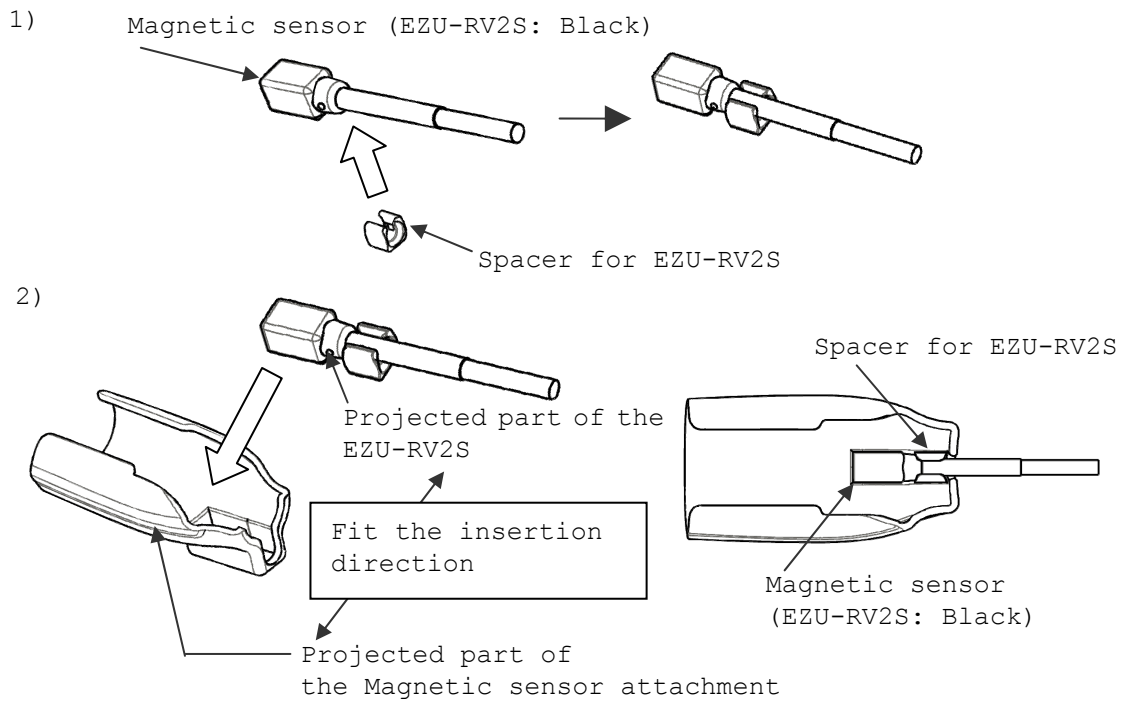

Fig. 4 How to attach the Magnetic sensor attachment

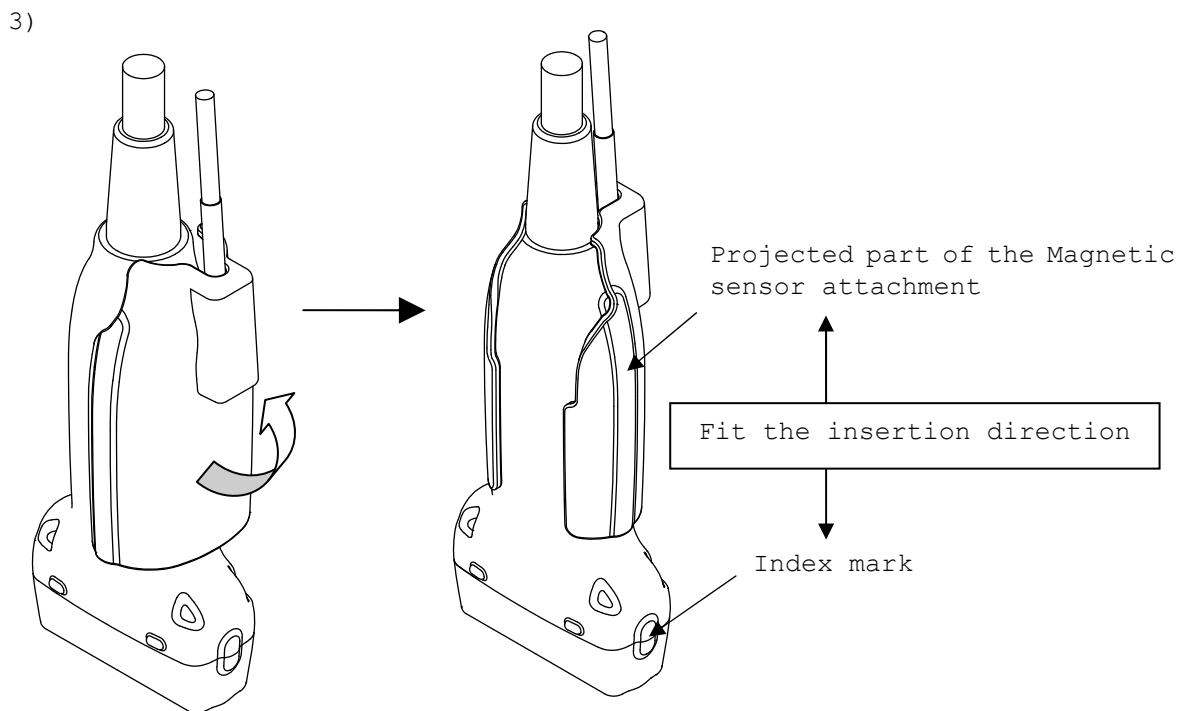

Fig. 5 How to attach the Magnetic sensor attachment

⚠ CAUTION

- Never attach the magnetic sensor attachment to the probe in the incorrect direction, otherwise it may result in false diagnosis.
- Never forget to attach the spacer for EZU-RV2S to the magnetic sensor, otherwise it may result in false diagnosis.

4.1.2 How to release the Magnetic sensor

The procedure of releasing the magnetic sensor from the probe is as follows.

- 1) Turn around the magnetic sensor attachment and release it from the probe as shown in Fig. 6.

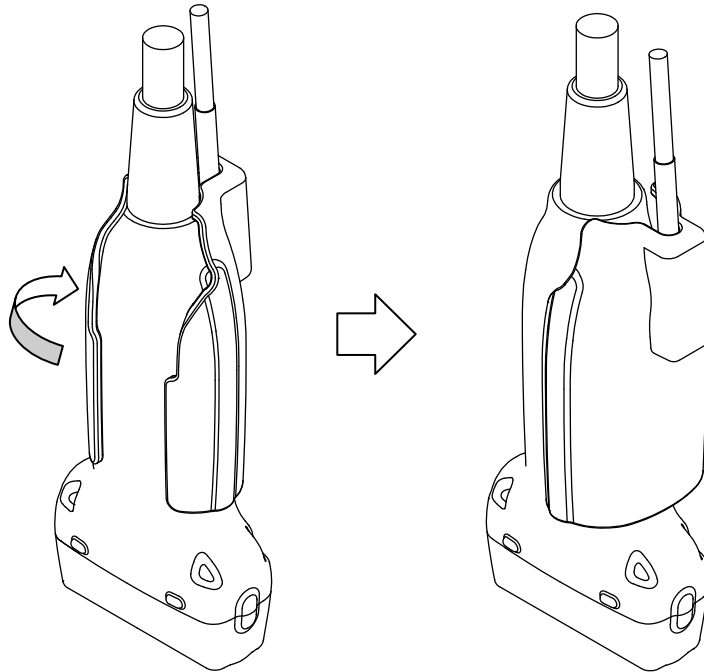

Fig. 6 How to release the Magnetic sensor attachment from the probe

- 2) Release the magnetic sensor from the magnetic sensor attachment as shown in Fig. 7 and release the spacer from the magnetic sensor.

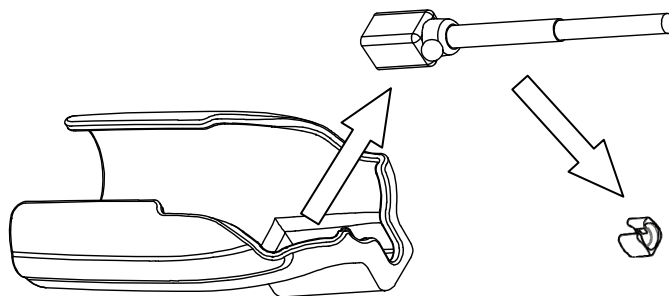

Fig. 7 How to release the Magnetic sensor from the Magnetic sensor attachment

⚠ CAUTION

The spacer for EZU-RV2S is small, please do not lose the spacer.

4.2 Magnetic sensor EZU-RV3S

The EZU-RV3S is shown in Fig. 8.

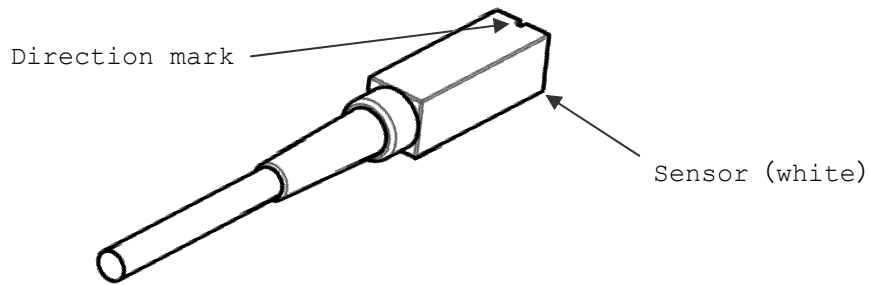

Fig. 8 Magnetic sensor EZU-RV3S

4.2.1 How to attach the Magnetic sensor

The procedure of attaching the magnetic sensor is as follows.

- 1) Attach the magnetic sensor into the probe with the correct direction as shown in Fig. 9.
- 2) Place the magnetic sensor attachment on the probe as shown in Fig. 10. Fit the projected part of the magnetic sensor attachment in the index mark of the probe.

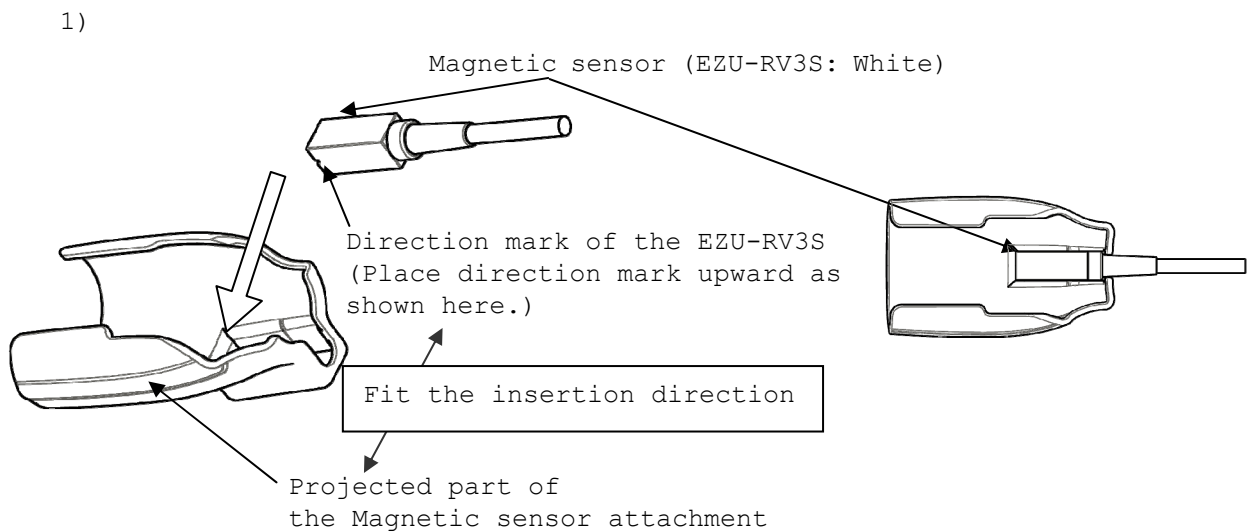

Fig. 9 How to attach the Magnetic sensor attachment

2)

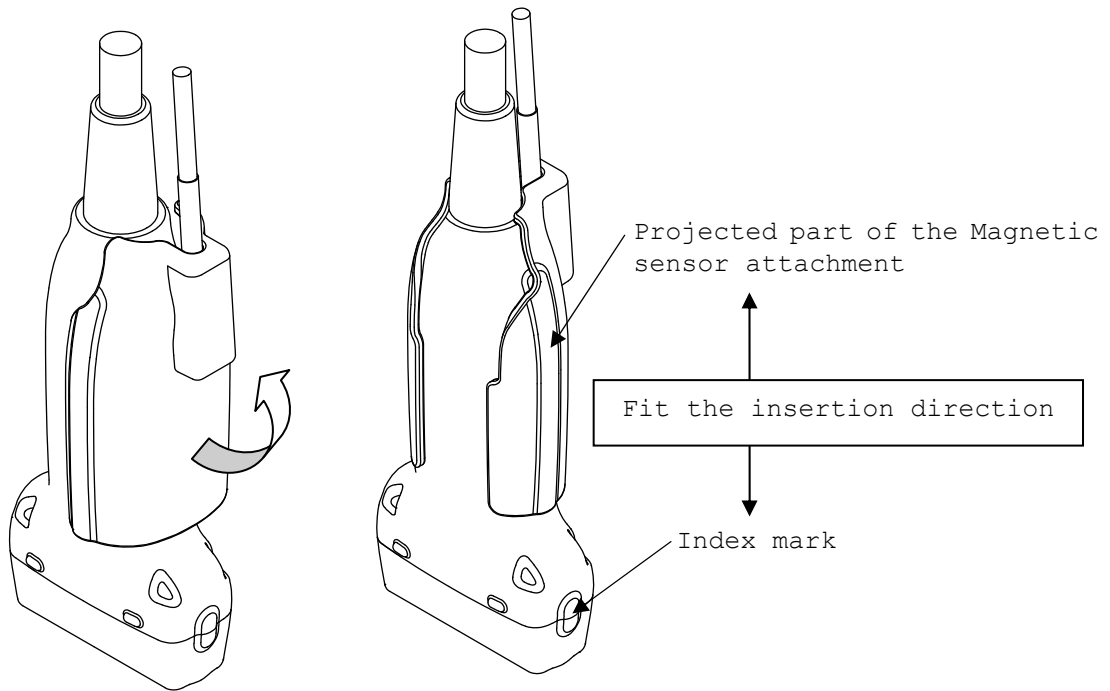

Fig. 10 How to attach the Magnetic sensor attachment

⚠ CAUTION

Never attach the magnetic sensor attachment to the probe in the incorrect direction, otherwise it may result in false diagnosis.

4.2.2 How to release the Magnetic sensor

The procedure of releasing the magnetic sensor from the probe is as follows.

- 1) Turn around the magnetic sensor attachment and release it from the probe as shown in Fig. 11.

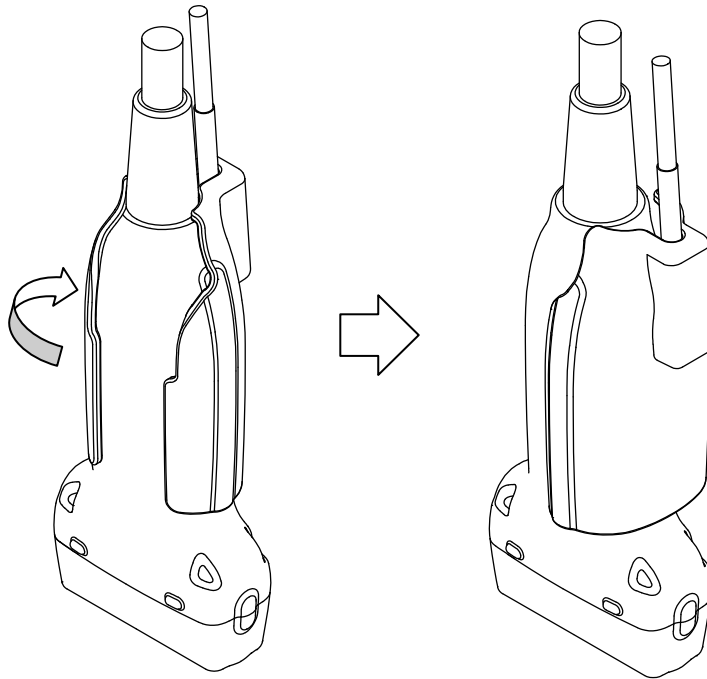

Fig. 11 How to release the Magnetic sensor attachment from the probe

- 2) Release the magnetic sensor from the magnetic sensor attachment as shown in Fig. 12.

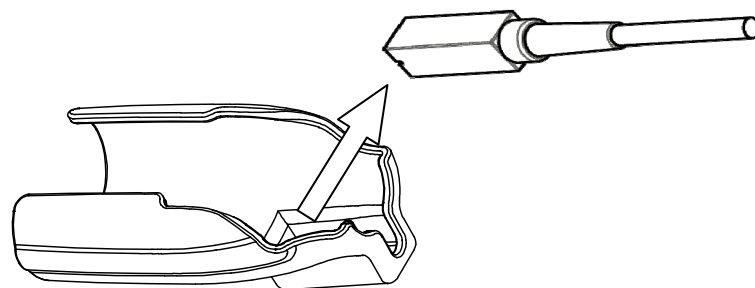

Fig. 12 How to release the Magnetic sensor from the Magnetic sensor attachment

4.3 Elasto Coupler

4.3.1 How to attach the Elasto Coupler

To use elastography, attach the elasto coupler as shown below. Attach the elasto coupler on the probe as straight as possible as shown in Fig. 13.

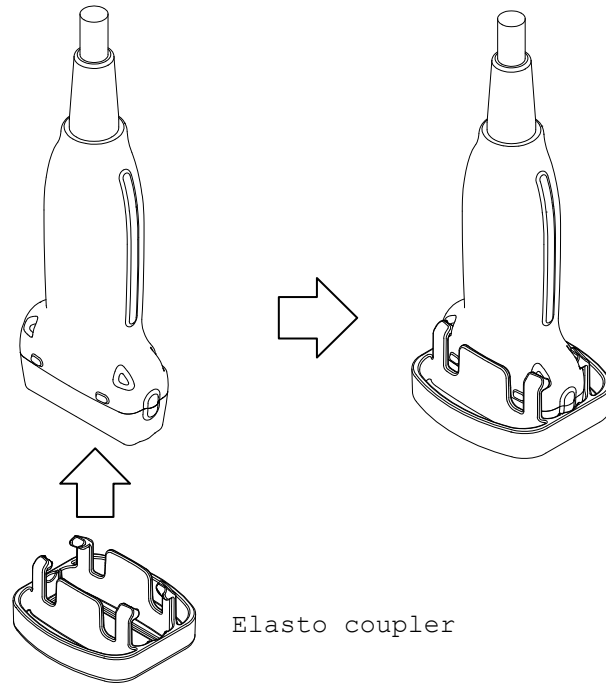

Fig. 13 How to attach the Elasto coupler

4.3.2 How to release the Elasto Coupler

Release the elasto coupler from the probe as shown in Fig. 14.

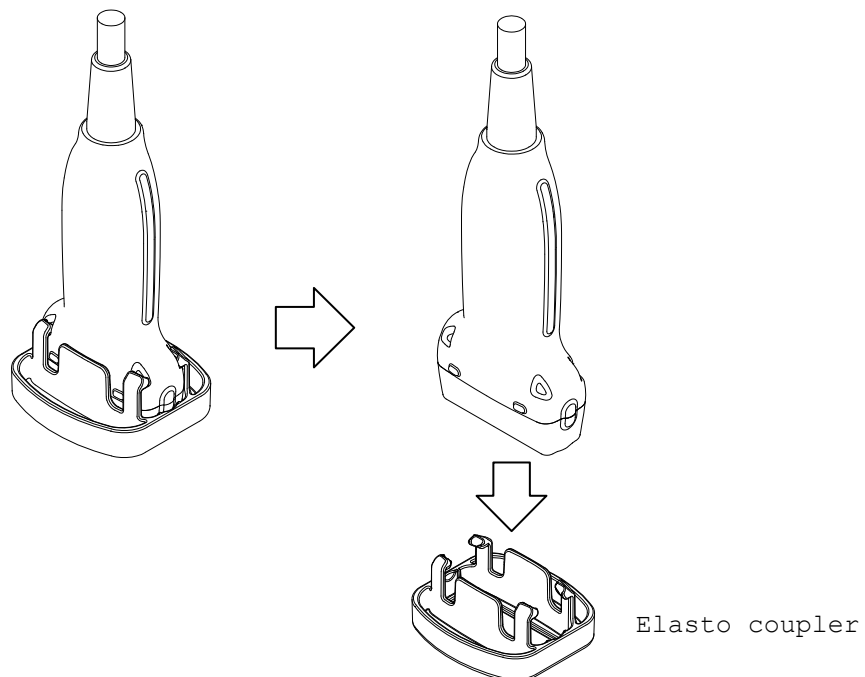

Fig. 14 How to release the Elasto coupler

5. Reprocessing Procedure



The probe, magnetic sensor attachment and spacer for EZU-RV2S must be reprocessed after each use. Refer to the reprocessing instruction in this chapter.

Please refer to the instruction manual of EZU-PA7L1 about the method of handling, cleaning and sterilizing the coupler attachment EZU-PA7L1.

WARNINGS	<ul style="list-style-type: none">- The probe is delivered unsterile. Prior to the first use, reprocess the probe.- Temperature should not exceed 60°C during reprocessing.- Probe connector is not water resistant.
Limitations on reprocessing	The probe is not completely submersible. The immersible part is shown in Fig.1. The un-immersible part should be disinfected by wipe disinfection.
Transportation before using	The probe should be packed in a sterile pouch or container to transport from Central Sterile Supply Department (CSSD) to an operating room. Be careful not to damage the sterile pouch or container during transportation.

Levels of reprocessing requirements:

Depending on the application of the product and with regard to risk evaluation, the user has to classify the medical device according to the current Medical Device Directive for processing of medical devices as uncritical, semi-critical or critical. Supporting information concerning this topic is listed in the table below. The user is responsible for correct classification of the medical device.

Classification	Definition	Processing
uncritical	Application part only contacts intact and uninjured skin	Cleaning Disinfection
semicritical	Application part contacts mucosa (intracavitary application)	Cleaning Disinfection (Disinfectant with virucidal effect)
critical	Application part contacts intracorporeal tissue directly (operative application)	Cleaning Disinfection (Disinfectant with virucidal effect - minimum) Sterilization

The flowchart of the reprocessing process of this probe is as follows.

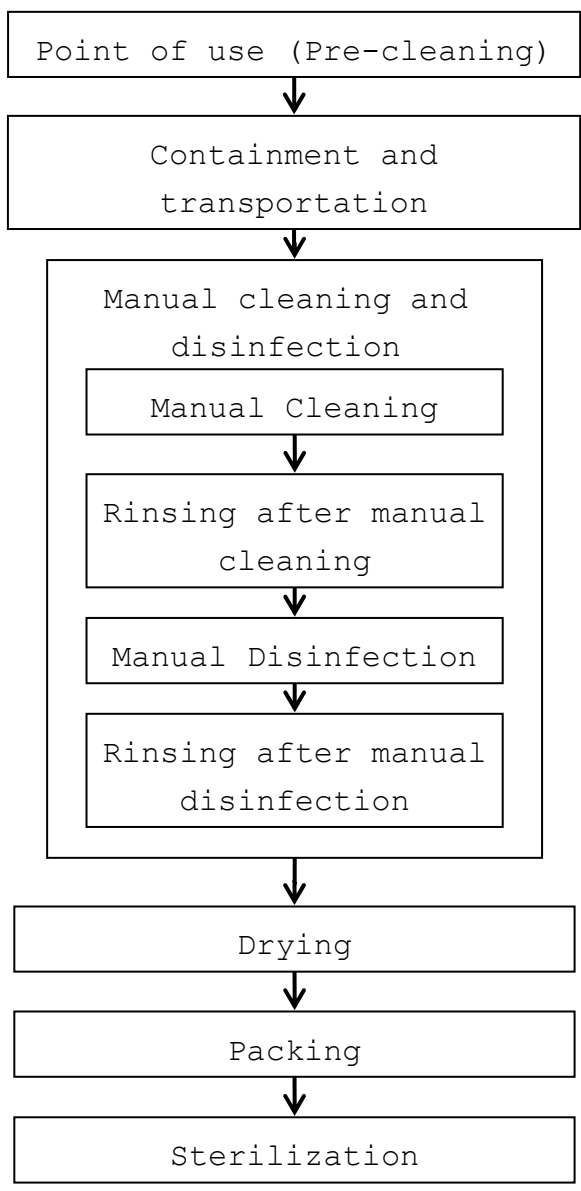

5.1 Point of use (Pre-cleaning)

Pre-cleaning should be done immediately after each use.
The procedure is as follows:

Point of use
(Pre-cleaning)

- 1) Remove the probe cover and any accessories from the probe.
- 2) Clean the probe of all patient's blood or fluid with running tap water until the surface of the probe looks visually clean.
- 3) Wipe the whole surface of the probe with gauze pad and remove superficial visible impurities.

5.2 Containment and transportation

Putting the contaminated equipment into exclusive shock and damage proof container for transportation is recommended. It is recommended that instruments are reprocessed as soon as possible and not later than 4 hours after usage.

Containment and
transportation

5.3 Manual Cleaning and disinfection

Prepare following items before manual cleaning and disinfection:

- a) Detergent: Cidezyme® (Johnson & Johnson, #2258) or another cleaning agent with approved material compatibility for this medical device.
- b) Disinfectant: Cidex® OPA (Johnson & Johnson, # 20391) or another disinfectant with approved material compatibility for this medical device.
- c) Two tanks, one for cleaning and one for disinfection - optional:
1 additional tank for rinsing with deionized/tap water (sufficient size for immersion of the submergible part of the probe at full length)
- d) Soft, fluff free cloth or single use towel
- e) Personal protective equipment (gloves, water repellent protective skirt, face protection mask or protective glasses, see also instructions of the manufacturer for the detergent and the disinfectant)

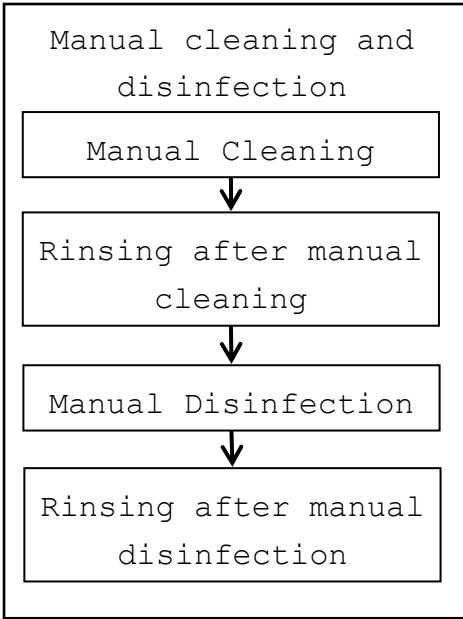

Manual Cleaning:

Prepare the detergent solution in a tank with cold water (please follow the instructions of the detergent manufacturer regarding application, dilution and contact time).

A) EUP-L73S

- 1) The temperature of the detergent solution should be between 15-30 °C, concentration is 1.6%. Please note the minimum contact time of the detergent in the manufacturer's instruction. If a differing detergent is used, please also note the approved material compatibility for the medical device.
- 2) Immerse the immersible part of the probe without connector into the diluted detergent solution (see Fig. 15). Wipe the immersible part of the probe under the surface of the detergent solution with a soft cloth to remove all visible soil. Be sure that all grooves of the probe are implemented during the cleaning process.
- 3) The immersible part of the probe should be left in the detergent solution according to the specified contact time of the detergent manufacturer.
- 4) Wipe the un-immersible parts of the probe with a soft cloth dipped with the detergent solution.
- 5) Rinse the probe with running tap water for 1 minute. (alternatively: immerse the immersible part of the probe in a tray filled with deionized water/tap water (see Fig. 15) for 5 min.)
- 6) Visually check the outer surface of the probe for cleanness. If necessary, use magnifying glass for visually check. If there is still soil visible, repeat all above steps.

B) Magnetic sensor attachment and Spacer for EZU-RV2S

- 1) The temperature of the detergent solution should be between 15-30 °C, concentration is 1.6%. Please note the minimum contact time of the detergent in the manufacturer's instruction. If a differing detergent is used, please also note the approved material compatibility for the medical device.
- 2) Immerse the magnetic sensor attachment and the spacer for EZU-RV2S into the diluted detergent solution. Wipe them under the surface of the detergent solution with a soft cloth to remove all visible soil.

- 3) The magnetic sensor attachment and the spacer for EZU-RV2S should be left in the detergent solution according to the specified contact time of the detergent manufacturer.
- 4) Rinse the magnetic sensor attachment and the spacer for EZU-RV2S with running tap water for 1 minute. (alternatively: immerse them in a tray filled with deionized water/tap water (see Fig. 15) for 5 min.)
- 5) Visually check the outer surface of the magnetic sensor attachment and the spacer for EZU-RV2S for cleanness. If necessary, use magnifying glass for visually check. If there is still soil visible, repeat all above steps.

Manual disinfection:

A) EUP-L73S

- 1) Prepare the disinfectant solution in a tank with cold water (please follow the instructions of the disinfectant manufacturer regarding application, concentration, microbiological efficiency, service life and contact time).
- 2) Confirm the concentration of the disinfectant before immersing the probe. Although Cidex® OPA does not need to be diluted, it is recommended to use test strips to verify the concentration. The test strips can indicate whether or not the concentration is above the Minimum Effective Concentration (MEC). Please also note the expiration date of the test stripes. Temperature of disinfectant solution should be minimum 20 °C. The minimum contact time is 5 minutes. If a different disinfectant is used, follow the manufacturer's instructions. Please also consider the material compatibility for the medical device.
- 3) Immerse the immersible part of the probe into the disinfectant (see Fig. 15). Set a clock to insure the recommended contact time which is 5 minutes.
- 4) Rinse the immersible part of the probe with deionized water for 1 minute. (alternatively: immerse the immersible part of the probe in a tray filled with deionized water (see Fig. 15) for 5 min.)
- 5) Visually check the outer surface of the probe for leavings of the disinfectant. If necessary, repeat the rinsing.

B) Magnetic sensor attachment and Spacer for EZU-RV2S

- 1) Prepare the disinfectant solution as stated in the procedure for the probe.
- 2) Immerse the magnetic sensor attachment and the spacer for EZU-RV2S into the disinfectant (see Fig. 15). Set a clock to insure the recommended contact time which is 5 minutes.
- 3) Rinse the magnetic sensor attachment and the spacer for EZU-RV2S with deionized water for 1 minute. (alternatively: immerse them in a tray filled with deionized water (see Fig. 15) for 5 min.)
- 4) Visually check the outer surface of the magnetic sensor attachment and the spacer for EZU-RV2S for leavings of the disinfectant. If necessary, repeat the rinsing.

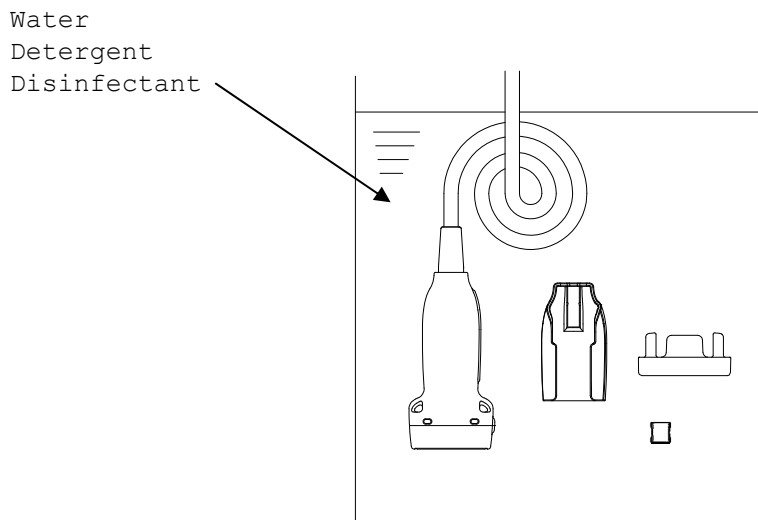

Fig. 15 Immersion of the probe, the magnetic sensor attachment, the spacer for EZU-RV2S and the elasto coupler

5.4 Drying

- 1) Wipe the equipment with a single-use, fluff-free wipe or towel to remove moisture from the surface of the equipment.
- 2) Dry the probe naturally in an ambient temperature between 15-30°C for a minimum of 4 hours. Alternatively the probe can be dried using a drying heater at a temperature of less than 60°C.

5.5 Inspection

Inspect the equipment for any damage such as crack, scratch or deformation. Do not use it if any damage is found.

5.6 Packaging

Pack the probe in a sterile barrier such as Polypropylene fleece or transparent package made from Polyethylene film and Tyvek®, and then place it into a tray. The tray should be also covered with a sterile barrier.

Additionally the probe can be placed on plastic mesh wires supplied for plasma sterilization and then packed as mentioned above.

The probe can be packed in a simple or double packing.

Please note that the size of a sterile barrier should be large enough to be able to pack the equipment leaving sufficient space to seal it completely.

A sterile barrier should be sealed by an appropriate sealing machine and it is important to confirm that the package is sealed completely. If the sealing is not complete, pack and reseal again.

5.7 Sterilization

The probe and accessory can be sterilized using either ethylen oxide gas (EtO) sterilization or plasma sterilization (see table in the next page).

Follow the manufacturer's instructions of the sterilizer regarding usage, temperature and sterilization-time.

The sterilization method and operating conditions are as follows.

Sterilization Method	Condition
Plasma Sterilization: STERRAD® 50, 100S or 200 (*)	Short Cycle
Plasma Sterilization: Sterrad® NX or 100NX (*)	Standard cycle
ETO Sterilization	<ul style="list-style-type: none"> ➤ Gas Type: 10% EO/ 90% HCFC ➤ Temperature: 50-55°C ➤ Exposure Time: More than 120 minutes ➤ Pressurization: 162-200kPa ➤ Depressurization: 13-8kPa ➤ Relative humidity: 40-90% ➤ Aeration is minimum 12 hours

*STERRAD® systems are manufactured by "Johnson & Johnson"

! WARNING

- 1) Before performing sterilization, check that the operation data of sterilizer are in conjunction with min. and max. data applicable for the probe and the attachment.
- 2) Do not sterilize the probe and the attachment by Steam Autoclaving. If you autoclave them, they suffer serious damage and will be not functional

The packaging procedure is as follows.

- 1) Put the probe into TYVEK pouch.

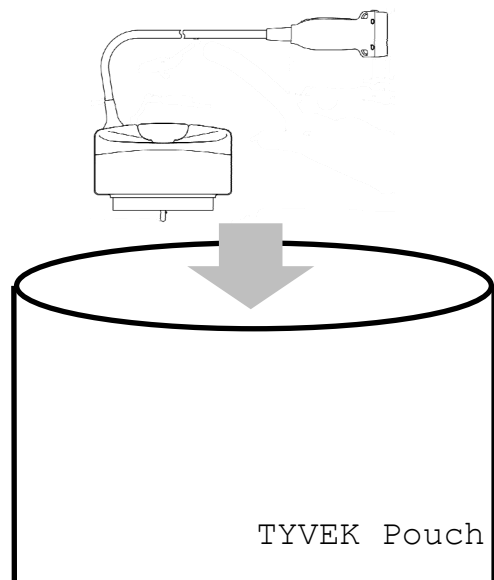

Fig. 16 Packaging
in the pouch

2) Seal the TYVEK Pouch using a heat sealer. Ensure that the seal is complete.

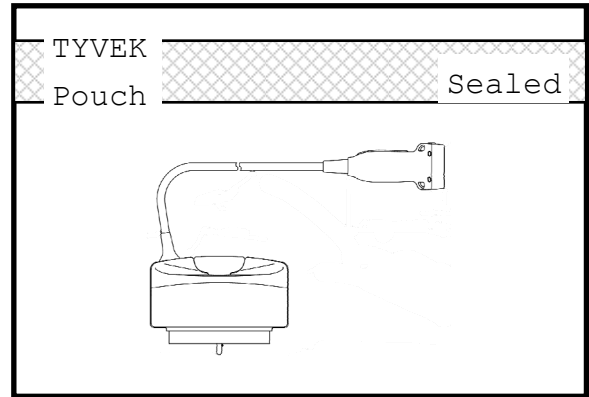

Fig. 17 Sealing

3) Put the sealed pouch into a tray or plastic mesh wire for sterilization.

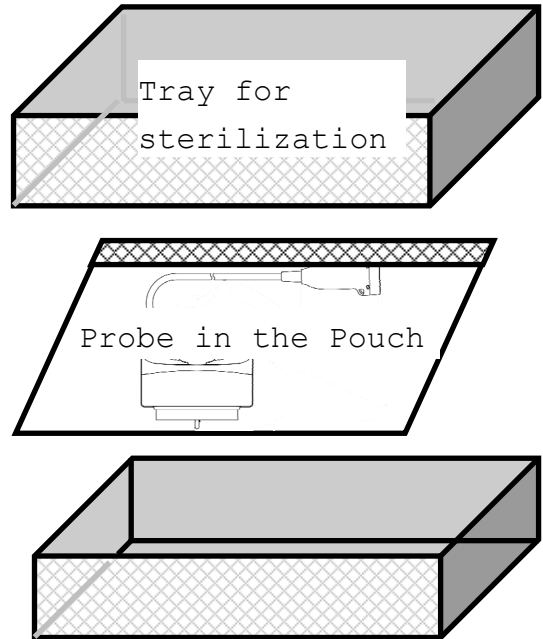

Fig. 18 Packaging in a tray

5.8 Storage



Store the equipment in a cool, dustproof and dark space to avoid high temperature, humidity and direct sunlight. Limitations for the time for sterilized equipment belong to package.

6. Maintenance and Safety Inspection



- 1) After using the probe, the magnetic sensor attachment, the spacer for EZU-RV2S and the elasto coupler, it should be cleaned and disinfected or sterilized following **"5. Reprocessing Procedure"**, then store it in a cool and dark place avoid high temperature and humidity, direct sunlight.
- 2) Visually inspect the surface of the probe head, the housing, the cable and the connector for any crack, scratch or denaturalization. If you find any damage, do not use the probe, and contact a service support immediately.
- 3) Visually inspect the surface of the magnetic sensor attachment, and the spacer for EZU-RV2S for any crack, deformation or denaturalization. If you find any damage, do not use them and contact a service support immediately.
- 4) Visually inspect the surface of the elasto coupler for any crack, deformation or denaturalization. If you find any damage, do not use the elasto coupler, and immediately contact a service support.

7. Safety Precautions

WARNING

- Never use the probe if the probe is damaged.
- Do not use the latex probe cover for latex sensitive patients. The probe cover, which contains latex, may cause allergic reactions such as itching, rubor, urticaria, swelling, fever, anhelation, wheezing, depression of blood pressure, and shock.

CAUTION

- Keep the acoustic power low and minimize the ultrasound exposure time for the examination of an early pregnancy.
- Do not expose the connector to water or other liquids. The connector is not waterproof.
- Do not hit or drop the probe. The probe is easily damaged by mechanical shock.
- Do not use detergents and disinfectants other than listed in "8.2 Suppliers list".
- Use a sterile probe cover to avoid staining or damaging the acoustic lens.
- Clean, disinfect and sterilize the probe, the magnetic sensor attachment and the elasto coupler before the first use as they are not sterilized in the factory.
- Use only the soft cloth or tissue to clean the acoustic lens.
- A biopsy should be performed only by a well-trained physician.
- Do not attach unapproved devices to the probe.

8. Specifications

8.1 Probe

Type	: EUP-L73S Linear Array Probe
Center Frequency	: 6.5MHz
Technology	: Linear Array Probe
Dimensions	: See Fig. 19.
Weight	: Approx. 0.78kg (Including cable and connector)
Scanning width	: 38mm
Probe materials	: Biocompatible allergy free components
Acoustic output	: According to IEC60601-2-37 (See Main Unit manual.)
Applicable system	: Depending on production and upgrade status For detailed information, contact a service support.
Classification	: MDD classification IIa.
Cleaning	: Applicable detergents are listed in the suppliers list
Disinfection	: Applicable disinfectants are listed in the suppliers list
Sterilization	: ETO gas sterilization Plasma sterilization

Operating conditions:

Ambient temperature	: +25 - +35°C
Contact surface temperature (Temperature of examinee)	: max. 42°C
Relative humidity	: 30 - 85%

Storage conditions:

Temperature	: -10 - +55°C
Relative humidity	: 10 - 95% (subject to no condensation)

8.2 Suppliers List

The products listed below are seriously tested and approved for use with the Linear Array Probe EUP-L73S.

Product name	Manufacturer	Purpose
Cidezyme	Johnson & Johnson	Enzymatic detergent
Meliseptol HBV-Tücher	Braun	Disinfectant
Incides	Henkel Hygiene GmbH	Disinfectant
Incidin Liquid	Henkel Hygiene GmbH	Disinfectant
Incidur Spray	Henkel Hygiene GmbH	Disinfectant
STERANIOS 2%	ANIOS	Disinfectant
ANIOXYDE1000	ANIOS	Disinfectant
Virkon S	ANTEC	Disinfectant
ASPHENE SPRAY	RIVADIS Laboratories	Disinfectant
Bacillol 25	BODE CHEMIE	Disinfectant
CIDEX	Johnson & Johnson	Disinfectant
CIDEX plus	Johnson & Johnson	Disinfectant
CIDEX OPA	Johnson & Johnson	Disinfectant
Gigasept FF	Schülke & Mayr	Disinfectant
Tristel 1 Day	Tristel Company	Disinfectant
Tristel Multi-Shot	Tristel Company	Disinfectant
ALKACIDE	ALKAPHARM	Disinfectant
ALKAZYME	ALKAPHARM	Cleaner

Please contact your local distributor for a current version of the "Disinfectant/Sterilization Method Compatibility for Ultrasound Probe and Accessory List"

9. Disposal of the probe

Recycle or dispose the equipment properly in compliance with your organizational rules and your local laws.

CAUTION

Before disposing the equipment, disinfect or take other infection-prevention measures.

Disposal of the equipment without taking the proper preventative measures can lead to infection.

Waste Electrical and Electronic Equipment (WEEE) Directive

The illustration on the right is required by the EU WEEE Directive to appear on all electrical and electronic equipment.

For proper disposal of this product in an EU nation, contact an EU office or agency and observe appropriate local and national regulations and laws.



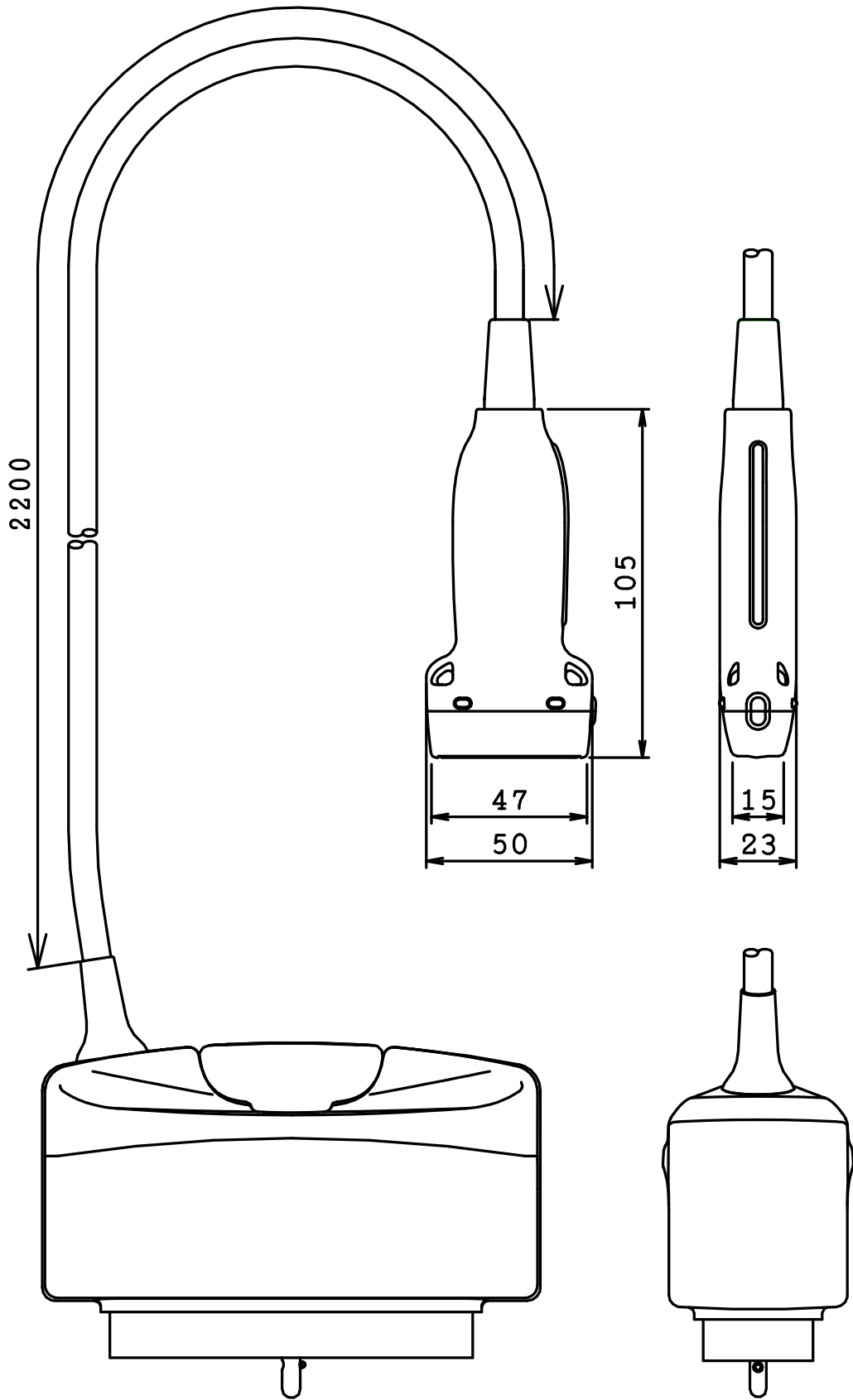

Unit:mm

Fig. 19 Dimensions

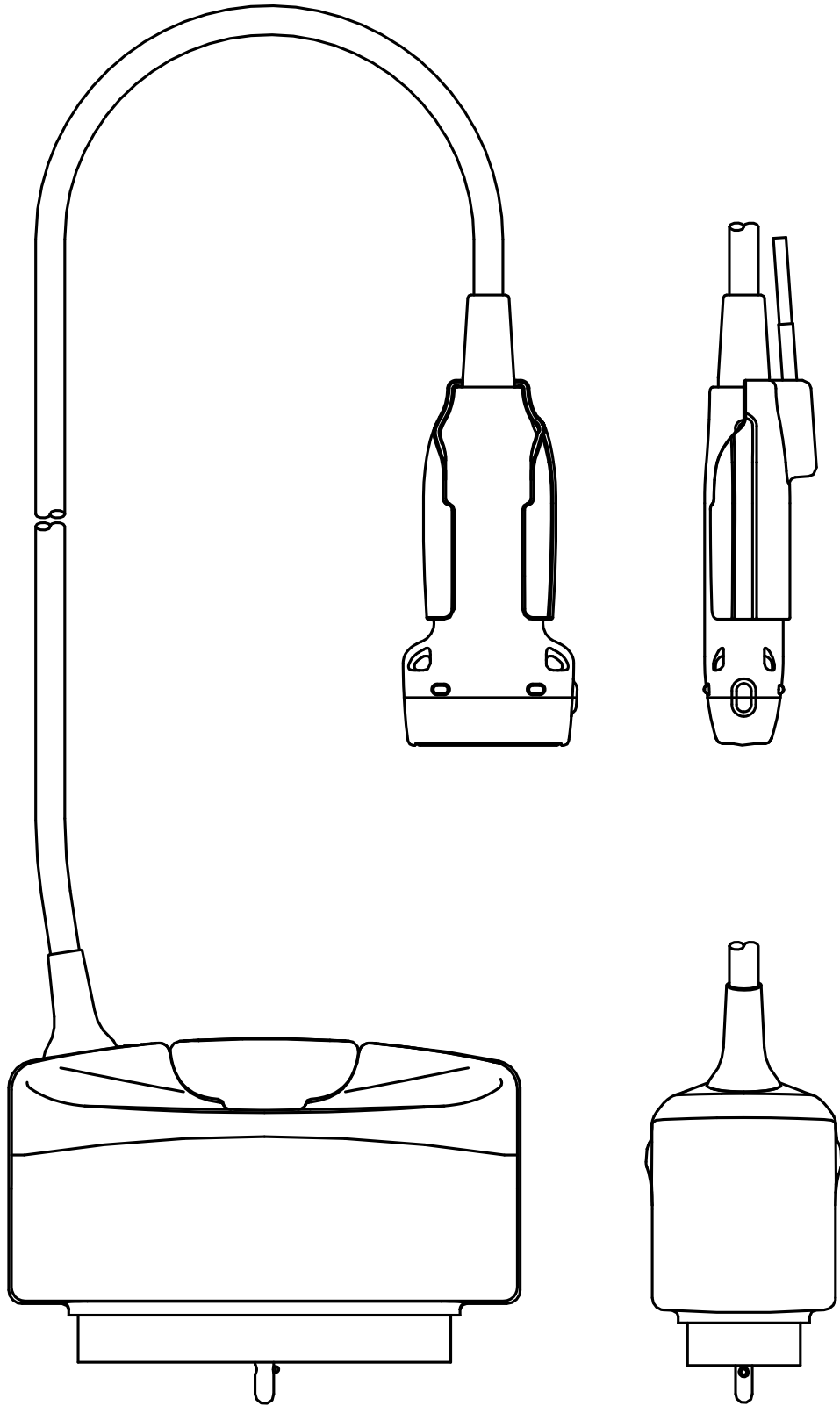

Fig. 20 External view (with the Magnetic sensor attachment)

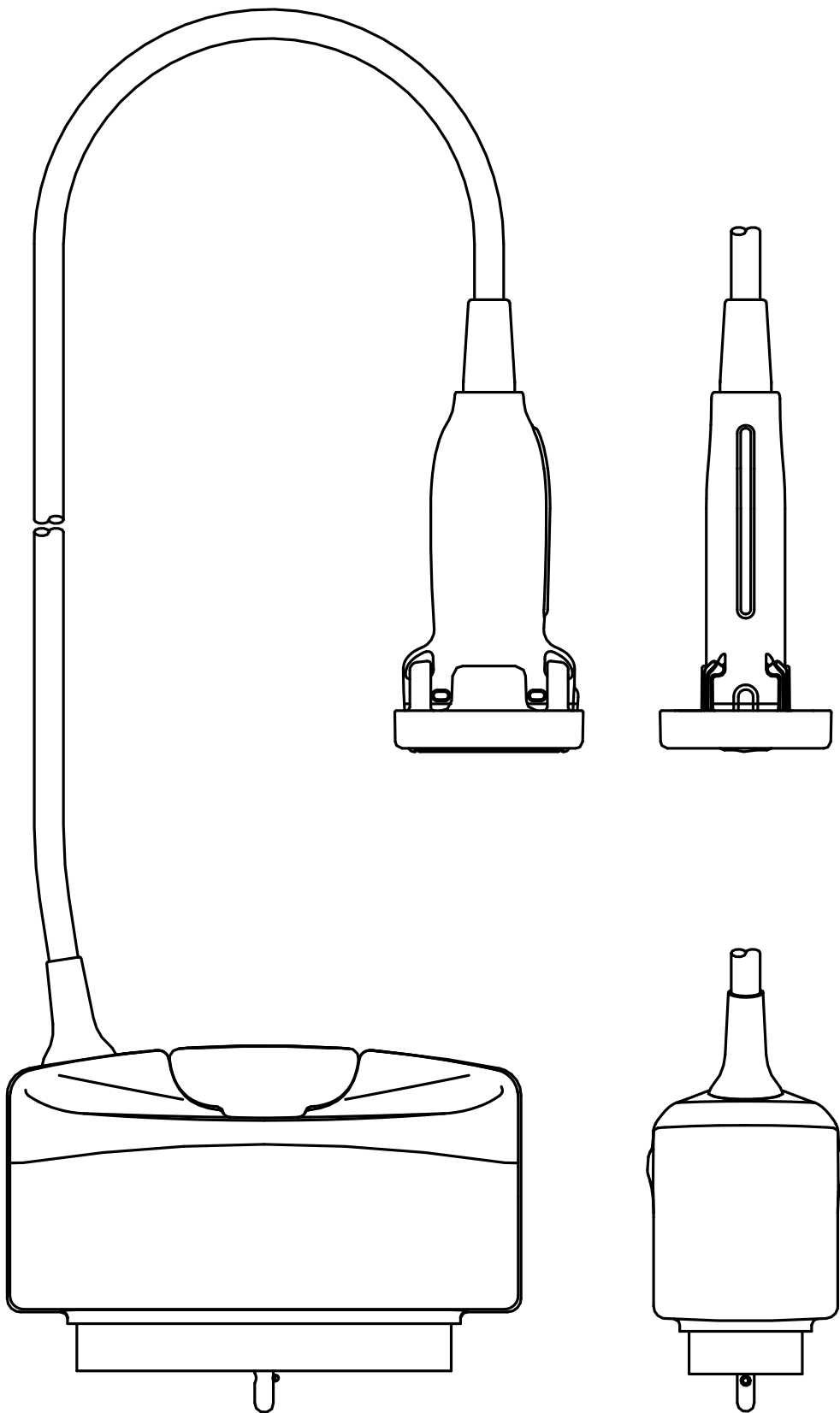

Fig. 21 External view (with the Elasto coupler)