



MEDICAL TREADMILL



OWNER'S MANUAL TMX428 TMX428CP



Contact Information

The model TMX428 TRACKMASTER® treadmill is designed to be interfaced with a variety of ECG and VO₂ systems. If you have a question or need assistance, please contact your system integrator first.

Manufactured by:

Full Vision Inc.
3017 Full Vision Drive
Newton, KS 67114 USA
<http://www.full-vision.com>
Phone: (316)-283-3344
Fax: (316)-283-9522
Email: sales@full-vision.com

**Authorized Representative
In European Union
(Regulatory affairs only)**

Emergo Europe
Molenstraat 15
2513 BH The Hague
The Netherlands

WARNING**MODIFICATION IS PROHIBITED**

The TRACKMASTER® is manufactured to exacting standards both in physical form and in component selection. The components used in our products have been selected with performance and medical safety in mind. The treadmill has been engineered and certified to conform to the list of medical and safety regulatory standards which appear on the next page. Modification or part substitution of any kind is strictly forbidden. Any deviation in component replacement, physical or electrical modification will result in loss of medical safety certification and warranty of this product. Modifications to this equipment may put the patient at risk of electrical shock or hardware malfunction.

Contact TRACKMASTER® Service department for all your repair part needs.

AVERTISSEMENT**MODIFICATION EST INTERDITE**

Le TRACKMASTER® est fabriqué selon des normes rigoureuses tant dans la forme physique et à la sélection des composants. Les composants utilisés dans nos produits ont été sélectionnés avec la sécurité de la performance et médicale à l'esprit. Le tapis roulant a été conçu et certifié conforme à la liste des normes réglementaires médicales et de sécurité qui apparaissent sur la page suivante. Substitution de modification ou d'une partie quelconque est strictement interdite. Tout écart dans le remplacement des composants, physique ou modification électrique entraînera la perte de la certification de la sécurité médicale et la garantie de ce produit. Apportées à cet appareil peuvent mettre le patient au risque de choc électrique ou un dysfonctionnement du matériel.

Contactez TRACKMASTER® département service pour tous vos besoins en pièces de rechange.

TRACKMASTER® is a registered trademark of Full Vision Inc.

TRACKMASTER® is protected by the following US Patents: 5,431,613 and 5,320,589.

Regulatory and Safety Conformance

TRACKMASTER® meets the following safety and regulatory standards for FDA Class 1 motor operated physical medicine machines. TRACKMASTER® has been tested by Intertek Testing Services N.A Inc., and is listed by Engineering Testing Laboratories (ETL). However, the ultimate conformance to IEC 6060-1 2005-3rd edition is the responsibility of the system integrator when combined with other equipment. Additionally, all motorized equipment is potentially dangerous if used incorrectly. Before using the TRACKMASTER®, follow all precautions listed in this chapter and read the entire Owner's Manual thoroughly. Use the TRACKMASTER® only as described.

UL 1647

Issue: 2008/01/23 Ed: 4 UL Standard for Safety for Motor-Operated Massage and Exercise Machines

CAN/CSA C22.2#68

Issue: 2009/09/01 Ed: 7 Motor-Operated Appliances (Household and Commercial) General Instruction No.1: 2010/02/01 - General Instruction No.2: 2010/09/28

CSA C22.2#60601-1

Issued: 2008/02/01 Ed: 3 Medical Electrical Equipment - Part 1: General Requirements for basic Safety and essential performance

ICES 003 Industry Canada (IC) Verification

Issue: 2004/01/01 Issue No.4 Interference-Causing Equipment Standard, Digital Apparatus

IEC 60335-1 Low Voltage Directive for the European Union (EU)

Issued: 2004/07/01 Ed: 4.1 Household and Similar Electrical Appliances - Safety - Part 1: General Requirements; Corrigendum 1: 12/2005; Amendment 2: 05/2006; Corrigendum: 08/2006

IEC 60601-1

Issued: 2005/01/01 Ed: 3 Medical electrical equipment Part 1: General requirements for basic safety and essential performance Australia and Israel,

IEC 60601-1-2

Issued: 2007/03/01 Ed: 3.0 Medical Electrical Equipment - Part 1-2: General Requirements for Basic Safety and Essential Performance - Collateral Standard: Electromagnetic Compatibility - Requirements and Tests

AAMI ES60601-1

Issued: 2005/01/01 Medical electrical equipment Part 1: General requirements for basic safety and essential performance.

IEC CISPR 11-1 EMC Directive for the European Union (EU)

Issued: A1:2010 Electromagnetic Compatibility Requirements for Household Appliances, Electric Tools and Similar Apparatus Part 1: Emission Edition 5.0;

Federal Communications Commission (FCC) Verification for the United States

FCC 47CFR 15A

Issued: 2011/04/21 Title 47 CFR Part 15 Subpart A General Radiators Class A

Note: This equipment has been tested and found to comply with the limits for a Class B digital device, pursuant to part 15 of the FCC Rules. These limits are designed to provide reasonable protection against harmful interference when the equipment is operated in a commercial environment. This equipment generates, uses, and can radiate radio frequency energy and, if not installed and used in accordance with the instruction manual, may cause harmful interference to radio communications. Operation of this equipment in a residential area is likely to cause harmful interference in which case the user will be required to correct the interference at owner's expense.

Important Safety Information

The purchaser is solely responsible for the training, instruction, supervision and safety of all users of the TRACKMASTER® treadmill, and to use it as intended by the manufacturer. This device is intended to be used as a motion appliance to facilitate cardiac or VO₂ medical evaluation.

WARNING



Before permitting anyone to use the TRACKMASTER®, do the following:

- Warn each user about the risk of falling while the belt is in motion.
- Stress the need for caution.
- Demonstrate the proper mounting and dismounting methods.
- Show each user how to use the TRACKMASTER® as described in this manual.
- Ask each user to perform a supervised "test usage" at minimum belt speed to review and practice usage techniques.
- **Serious injury could result from loss of balance or falls. To reduce the possibility of serious injury, carefully observe the following precautions.**

-
- Read this Owner's Manual before operating the TRACKMASTER®.
 - Assist in off-loading the patient in the event of abnormal or unexpected operation of the treadmill.
 - If the treadmill is not responding properly, stop the treadmill, assist in removing the patient off the running belt, unplug the treadmill power supply, and seek factory authorized repair before attempting to restart the treadmill.
 - Never allow children or pets near the machine without qualified adult supervision.
 - Note the location of stop and/or emergency stop controls and their operation before starting a test or workout.
 - This device is not intended for use by persons with reduced physical, sensory or mental capabilities, or lack of experience and knowledge unless they have been given supervision or instruction concerning use of the appliance by a person responsible for their safety.
 - Verify the Patient and Operator both know how to stop the machine in the event of malfunction or emergency.
 - Patient should not wear loose fitting nylon material when exercising on this treadmill to avoid generating Electro Static Discharge.
 - Never attempt to remove any article of clothing while the running belt is moving.
 - All persons on and around the treadmill must wear enclosed, protective footwear. Shoe laces must be tight and not drape as to cause a trip or catch hazard. Sandals, flip flops, slippers and the like are not considered enclosed, protective footwear.

- Walk in the center of the running belt. Contact with the side rail and the moving belt could cause injury.



- The Patient must always wear the Stop Tether lanyard wrist strap before operating the TRACKMASTER®
- Place the treadmill on a hard, level and unobstructed surface. See Assembly / Set-up instructions in Chapter 5 of this manual.
- Check input power cord connection and location for hazardous pinch points before use.
- Check input communications cord connection (if equipped) for proper interface with all equipment.
- Keep all cords clear of patient to avoid trip hazards
- Never attempt to remove the motor pan hood or do electrical repairs yourself. Repairs should only be done by a factory authorized repair provider.
- Always unplug the TRACKMASTER® when servicing, inspecting or cleaning the treadmill.
- Routinely inspect the treadmill for loose parts.
- Inspect handrails and ensure they will support the Patient properly.
- Always start the running belt at its slowest speed before starting your workout.
- Do not step onto belt when it is moving.
- Always slow the running belt to its minimum speed before stopping.
- Keep hands, feet, and clothing away from any moving parts.
- Verify no one is near the elevation mechanism before operating. Never put any part of the body under any part of a running treadmill.
- Never drop or insert objects into any opening.
- Never drape garments, hook-up leads, or other equipment over the side rails or drop objects on the belt while the TRACKMASTER® is running.
- Do not allow moisture or oils to accumulate on equipment, creating a slip hazard.

WARNING

Serious injury or death could result from electrical shock. To reduce the possibility of electrical shock, carefully observe the following precautions.

- To disconnect the treadmill, set the power switch to the OFF position, and remove the plug from the outlet. When the power is off, the green light on the power switch is dark.
- Never operate the unit with a damaged power cord or plug.
- Power cord should be routed through frame mounted clamp and kept clear of elevation mechanism.
- Keep the power cord out of traffic areas and away from heated surfaces.
- Never use extension cords.
- Never operate the unit when it is wet.
- Never operate the unit if it is not operating properly.
- Always unplug the machine before service or maintenance is performed.
- Treadmill should be serviced by authorized technicians only.
- Operator should report any electrical shock when touching the treadmill and discontinue use immediately.
- Never use the treadmill outdoors.
- Immediately discontinue use and unplug the treadmill if you smell the distinctive odor of hot electrical components.

WARNING

Serious injury or death could result from electrical shock occurring during defibrillation. Never allow patient or operators near treadmill during defibrillation.

WARNING

Consult your physician prior to using this appliance to determine your physical readiness and capabilities. Stop exercising immediately and seek medical attention if you experience chest pain, dizziness or shortness of breath or if you experience symptoms of overexertion.

WARNING

Serious injury or death could result from operating the treadmill in the presence of explosive or flammable vapors and antiseptics.

WARNING

Potential foot crush injury at frontal end of treadmill at lift mechanism (landing gear) when treadmill is descending. Keep feet and hands away from this area at all times.

Potential foot crush injury at rearward side rail, rear of side rail and rear roller exists when treadmill approaches full elevation. Keep feet and hands away from this area at all times.

Information Importante de Sécurité

L'acheteur est entièrement responsable de l'utilisation, de la vigilance et de la sécurité des utilisateurs du tapis roulant TRACKMASTER® telle qu'elles ont été prévues par le fabricant. Cet appareil est destiné à être utilisé pour réaliser des entraînements physiques et faciliter l'évaluation des capacités cardiaques ou de VO₂ (Volume maximal d'oxygène).

AVERTISSEMENT



Avant de permettre à quiconque d'utiliser le TRACKMASTER®, faites ce qui suit:

- **Avertir l'utilisateur sur les risques de chute tandis que la ceinture est en mouvement.**
- **Insister sur la nécessité d'être prudent.**
- **Démontrer le bon montage et démontage des méthodes.**
- **Montrez à chaque utilisateur comment utiliser l'TRACKMASTER® comme décrit dans ce manuel.**
- **Demandez à chaque utilisateur d'effectuer un "usage test" supervisé à la vitesse de la courroie minimum d'examiner et de pratiquer les techniques d'utilisation.**
- **Des blessures graves pourraient résulter de la perte d'équilibre ou de chutes. Pour réduire les risques de blessures graves, observer les précautions suivantes.**

- Lisez le manuel / Service du propriétaire avant de faire fonctionner le TRACKMASTER®.
- Aider à déchargeant le patient en cas de fonctionnement anormal ou inattendu du tapis roulant.
- Si le tapis roulant ne répond pas correctement, arrêter le tapis roulant, aider à éliminer le patient hors du tapis roulant, débranchez l'alimentation tapis roulant, et de rechercher usine réparation agréé avant d'essayer de redémarrer le tapis roulant.
- Ne jamais laisser les enfants ou les animaux domestiques à proximité de la machine sans surveillance d'un adulte qualifié.
- Notez l'emplacement de l'arrêt et / ou les dispositifs d'arrêt d'urgence et leur fonctionnement avant de commencer un essai ou d'entraînement.
- Cet appareil n'est pas destiné à être utilisé par des personnes dont les capacités physiques, sensorielles ou mentales réduites, ou manquant d'expérience et de connaissances à moins qu'elles n'aient été formées et encadrées pour l'utilisation de cet appareil par une personne responsable de leur sécurité.
- Vérifiez que le patient et l'opérateur à la fois savoir comment arrêter la machine en cas de panne ou d'urgence.
- Le patient ne doit pas porter de nylon amples lors de l'exercice sur ce tapis roulant pour éviter de générer des décharges électrostatiques.
- Toutes les personnes sur et autour du tapis roulant doivent porter clos, chaussures de protection. Lacets doivent être serrés et ne pende pas à provoquer une excursion ou prendre des risques. Sandales, tongs, pantoufles et autres ne sont pas considérés comme clos, chaussures de protection.
- N'essayez jamais de retirer tout article d'habillement tandis que le tapis roulant est en mouvement.

- Toutes les personnes sur et autour du tapis roulant doivent porter des chaussures de protection. Les lacets doivent être serrés et ne pas pendre à provoquer une excursion ou prendre des risques. Sandales, tongs, pantoufles et autres ne sont pas considérés comme des chaussures de protection.
- Promenade dans le centre de la bande de course. Le contact avec le rail latéral et le tapis roulant peut provoquer des blessures.



- Le patient doit toujours porter le bracelet de corde d'arrêt avant d'utiliser le TRACKMASTER®.
- Placez le tapis roulant sur un disque. Surface plane et dégagée. Voir les instructions Assemblée / Set-up dans le chapitre 5 de ce manuel.
- Vérifiez le branchement du cordon d'alimentation d'entrée et l'emplacement des points de pincement dangereux avant utilisation.
- Vérifiez la connexion du cordon d'entrée (le cas échéant) pour l'interface correcte avec tous les équipements.
- Gardez tous les cordons à distance du patient afin d'éviter les risques de chute.
- Ne jamais essayer de retirer le capot du bac de moteur ou le faire vous-même les réparations électriques. Les réparations doivent être effectuées par un fournisseur de service autorisé de l'usine.
- Débranchez toujours le TRACKMASTER® lors de l'entretien, l'inspection ou le nettoyage du tapis roulant.
- Inspectez régulièrement le tapis roulant pour les pièces détachées.
- Inspectez les mains courantes et assurez-vous qu'elles soutiendront le patient correctement.
- Commencez toujours le tapis roulant à la vitesse la plus lente avant de commencer votre séance d'entraînement.
- Ne pas marcher sur la bande quand il est en mouvement.
- Toujours ralentir le tapis roulant à la vitesse minimum avant de s'arrêter.
- Gardez les mains, les pieds et les vêtements loin des pièces mobiles.
- Vérifiez que personne ne se trouve à proximité du mécanisme d'élévation avant de l'utiliser. Ne mettez jamais aucune partie du corps sous une partie d'un tapis roulant.
- Ne jamais laisser tomber ou insérer des objets dans les ouvertures.
- Ne jamais draper des vêtements, des fils de raccordement, ou tout autre équipement sur les rails latéraux ou de supprimer des objets sur la ceinture alors que le TRACKMASTER® est en marche.
- Ne laissez pas l'humidité ou des huiles s'accumuler sur les équipements, créant un risque de glissade.

AVERTISSEMENT



Des blessures graves ou même de mort par électrocution. Pour réduire les risques de choc électrique, respectez les précautions suivantes.

- Pour débrancher le tapis roulant, placez le commutateur d'alimentation sur la position OFF et retirez la fiche de la prise. Lorsque l'appareil est éteint, le feu vert sur l'interrupteur d'alimentation est sombre.
- Ne jamais faire fonctionner l'appareil avec un cordon d'alimentation ou une fiche endommagé.
- Le cordon d'alimentation doit être acheminé à travers le cadre pince monté et maintenu claire d'un mécanisme d'élévation.
- Gardez le cordon d'alimentation en dehors des zones de circulation et loin des surfaces chauffées.
- Ne jamais utiliser de rallonges.
- Ne jamais utiliser l'appareil quand il est mouillé.
- Ne jamais faire fonctionner l'appareil s'il ne fonctionne pas correctement.
- Toujours débrancher la machine avant que le service ou la maintenance est effectuée.
- Tapis roulant doit être réparé par un technicien agréé.
- L'opérateur doit signaler tout choc électrique en touchant le tapis roulant et cessez de l'utiliser immédiatement.
- N'utilisez jamais le tapis roulant en plein air.
- Cessez immédiatement d'utiliser et débrancher le tapis roulant si vous sentez l'odeur distinctive de composants électriques chauds.

AVERTISSEMENT



Des blessures graves ou la mort peuvent entraîner un choc électrique survenant pendant la défibrillation. Ne permettez jamais à des patients ou à proximité opérateurs tapis roulant pendant la défibrillation.

AVERTISSEMENT



Consultez votre médecin avant d'utiliser cet appareil pour déterminer votre niveau de préparation physique et de capacités. Arrêtez immédiatement l'exercice et consulter un médecin si vous ressentez des douleurs thoraciques, des étourdissements ou un essoufflement ou si vous ressentez des symptômes de surmenage.

AVERTISSEMENT



Des blessures graves ou la mort pourraient résulter de l'exploitation du tapis roulant en présence de vapeurs et antiseptiques explosives ou inflammables.

AVERTISSEMENT



Lésion par écrasement du pied potentiel à la fin frontal de tapis roulant à mécanisme de levage (train d'atterrissage) lorsque tapis roulant est en descente. Gardez les pieds et les mains loin de cette région à tout moment.

Potentiel lésion par écrasement de la nourriture au rail latéral vers l'arrière, à l'arrière de rail latéral et le rouleau arrière existe lorsque tapis roulant se rapproche de l'élévation complète. Gardez les pieds et les mains loin de cette région à tout moment.

<i>Contact Information</i>	<i>i</i>
<i>Regulatory and Safety Conformance</i>	<i>ii</i>
<i>Important Safety Information</i>	<i>iii to ix</i>

Chapter 1 Introduction

Notices	1-1
Serial Decal Information	1-3
RoHS/WEEE Directive	1-3
Equipment Symbols	1-4
Warning and Caution Decals	1-4

Chapter 2 Specifications

Directional Orientation	2-1
Safety Systems	2-1
Treadmill	2-2
Drive System	2-2
Speed Range	2-2
Incline Range	2-2
Running Surface	2-2
Communication Ports	2-2
Floor Surface Footprint	2-2
Operating and Storage Condition Recommendations	2-2

Chapter 3 Power Requirements

Operating Voltage	3-1
Receptacle Requirements (standard and optional)	3-1

Chapter 4 Hi Pot Test Instructions

4-1

Chapter 5 Assembly and Setup

Safe handling Guidelines	5-1
Initial Setup	5-2
TMX428CP Control Assembly	5-2
Location	5-3
Final Setup - Running Belt Tracking Adjustment	5-4
Final Setup - Running Belt Tension Adjustment	5-4
Final Setup - Drive Belt Tension Adjustment	5-4
Final Setup - Test Plug Procedure	5-5
Communication Access Location	5-6

Chapter 6 Operation Instructions

Programmable Control Instructions	6-1
Diagnostic Testing Mode Display.....	6-1
Manual Mode Display	6-1
Performance Information Display.....	6-2
Stop Tether	6-2
Control Panel Button Descriptions	6-3
Workout Graphics.....	6-4
Manual Operation	6-4
Built-in Program Operation	6-6
Pre-Programmed Cardiac Protocol Workouts	6-6
Pre-Programmed Fitness Workouts	6-9
User Defined Programming Workouts.....	6-10

Chapter 7 Preventive Maintenance

Daily Maintenance	7-1
Weekly Maintenance	7-2
Monthly Maintenance	7-2
Semiannual Maintenance	7-2
Belt Cleaning and Inspection	7-2
Running Belt Tracking Adjustment	7-3
Running Belt Tension Adjustment	7-4
Drive Belt Tension Adjustment	7-4
Exterior Care	7-6
Running Deck Maintenance	7-6

Chapter 8 Parts List with Part Numbers

Motor Mount Assembly	8-1
Circuit Board Assembly	8-2
Elevation Assembly	8-2
Pull Tether Assembly.....	8-3
Emergency Stop Assembly.....	8-3
Motor Pan Assembly	8-4
Motor Pan Assembly Wiring	8-6
Frame Assembly	8-9
Deck Assembly	8-11
Final Assembly	8-13
TMX428CP Controller Assembly.....	8-15

Appendix A Maintenance Log

Introduction

Congratulations on the purchase of your new TRACKMASTER® treadmill. These fine machines have been in production since 1977 and represent state-of-the-art design for heavy-duty institutional use. The TRACKMASTER® treadmill has gained worldwide recognition as one of the best and most dependable treadmills on the market. As a result, TRACKMASTER® has thousands of successful installations across the globe.

TRACKMASTER® treadmills are designed and built to withstand the extraordinary demands of medical motion devices. It is compatible with nearly all OEM testing devices. The model TMX428 is designed for cardiac stress tests and Model TMX428CP for pulmonary function testing.

This manual covers the installation, operation, of your new treadmill. If you have questions, contact your system integrator or TRACKMASTER® dealer. If you need further assistance, please call the TRACKMASTER® Service Support team at (316)-283-3344.

Notices

Three different levels of notices throughout this manual alert you to important information: Note, Caution, and Warning.

Avis

Les trois différents niveaux d'avis tout au long de ce manuel attirent votre attention sur des renseignements importants : Note, Attention et Avertissement.

Note

Note statements provide additional information. For example:

NOTE: For maximum efficiency, the TRACKMASTER® must have its own dedicated power outlet.

Note

Les déclarations des notes fournissent des informations supplémentaires. Par exemple.

NOTE: Pour une efficacité maximale, le TRACKMASTER® doit avoir sa propre prise de courant appropriée.

Caution

Caution notices inform you of potential hazards that could result in equipment damage or injury to the user. For example:

WARNING

Do not use silicone sprays to wax your treadmill deck. Using silicone sprays may void the warranty. Such sprays can bring about surface changes that cause you to slip.

Attention

Les avis d'Attention vous informent des dangers potentiels qui risquent d'entraîner des dommages à l'appareil ou des blessures pour l'utilisateur. Par exemple:

AVERTISSEMENT

N'utilisez pas des sprays à la silicone pour cirer la plate -forme du tapis roulant. L'utilisation du spray à la silicone peut annuler la garantie. Cette pulvérisation peut apporter des modifications à la surface qui peuvent vous faire glisser.

Warning

Warning notices alert readers to hazards that *will* result in serious injury or death. For example:

WARNING

Never open the hood of the TRACKMASTER[®] while it is plugged into a power outlet. Line voltage can cause severe injury or death.

Avertissement

Les avis d'avertissement alertent les lecteurs sur les dangers qui *provoqueront* de graves blessures ou le décès. Par exemple:

AVERTISSEMENT

Ne jamais ouvrir le couvercle du TRACKMASTER[®] alors qu'il est branché sur une prise de courant. La ligne d'alimentation entraînera la mort ou des blessures graves.

Serial Decal Information

This information must be supplied when contacting the factory for parts or service.

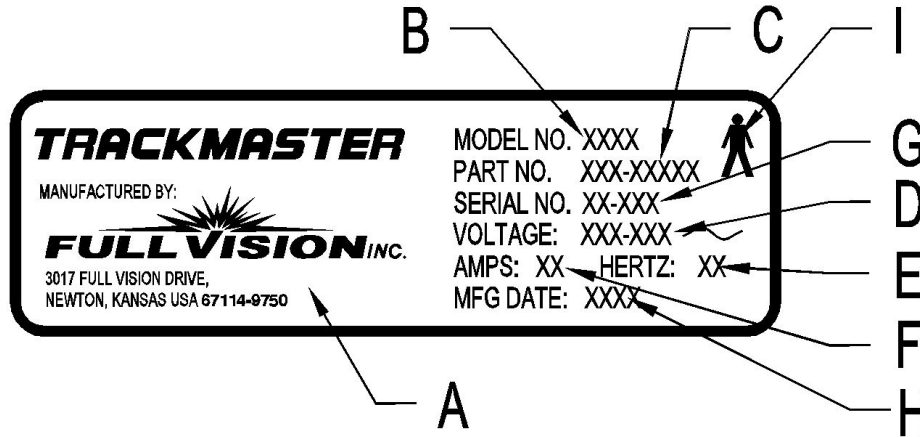

Item	Name	Description
A	Manufacturer	Full-Vision Inc.
B	Model Number	Identifies model of treadmill
C	Part Number	Manufacturers part number
D	Voltage	Specifies operating voltage of treadmill
E	Hertz	Specifies the electrical of treadmill
F	Amps	Specifies amperage of treadmill
G	Serial Number	Manufacturers assigned serial number
H	Mfg Date	Manufacturers date code
I	Type B Equipment	Device is suitable for the external application of type "B" applied parts.

European Union Disposal Requirements:



This equipment complies with the EU WEEE marking requirement for proper disposal of electrical and electronic waste in accordance with the European Directive 2011/65/EE. This directive calls for separation and recovery or reuse of used electrical or electronic equipment upon end of life EEE disposal.

The TRACKMASTER® must not be disposed of as unsorted municipal waste. Electrical or electronic components must be collected separately and disposed of in accordance with your local requirements and sources. The EEE program minimizes any potential effects on the environment and user health by eliminating the potential presence of hazardous substances in the waste stream. Customers should contact their local authorities or TRACKMASTER® Distributor for guidance in complying with the directive.

Equipment Symbols The following symbols appear on the equipment.

Symboles de l'équipement Les symboles suivants apparaissent sur l'équipement



Reading of the Owner's Manual is mandatory.
Lecture du manuel du propriétaire est obligatoire.



Elevation incline / decline adjustment.
Altitude ajustement de pente / recul.



Running belt speed adjustment.
Exécution de réglage de la vitesse de courroie.



This symbol warns of potential high electric voltage shock or injury potential. Areas of the TRACKMASTER® where this symbol appears are to be accessed only by trained service personnel

Ce symbole prévient de choc de tension électrique à fort potentiel ou potentiel de blessure. Domaines de la TRACKMASTER® où ce symbole apparaît doivent être accessibles uniquement par du personnel qualifié.



Protective earth (ground)
Mise à la terre



Alternating current
Courant alternatif



Device is suitable for the external application of the type "B" applied parts.
Dispositif approprié aux applications externes des pièces appliquées de type « B ».

Warning and Caution Symbols

Symboles d'Avertissement et d'Attention

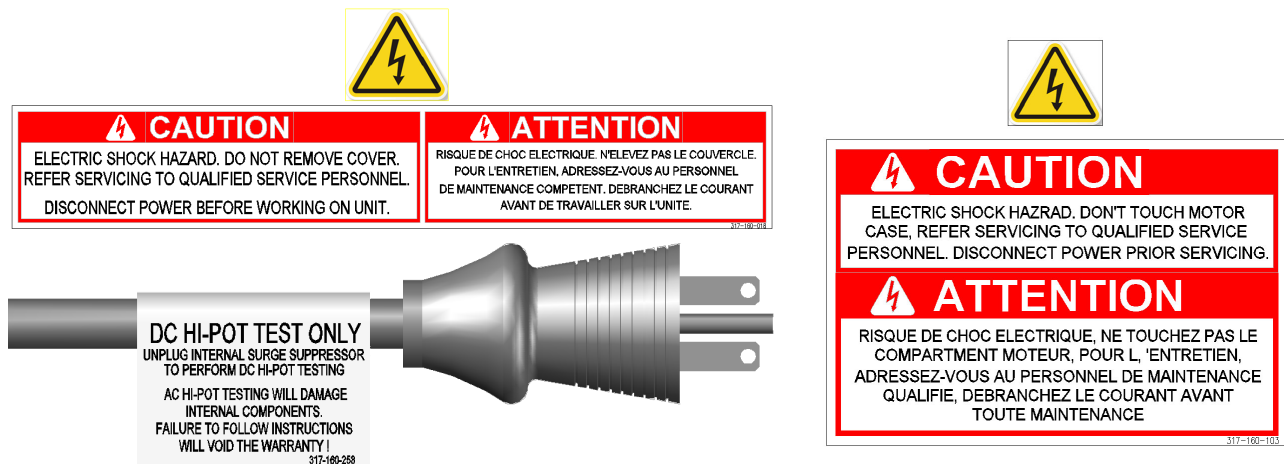

Specifications

Directional Orientation

References to left, right, front, and rear are based on the assumption that you are standing on the treadmill, facing the control console.

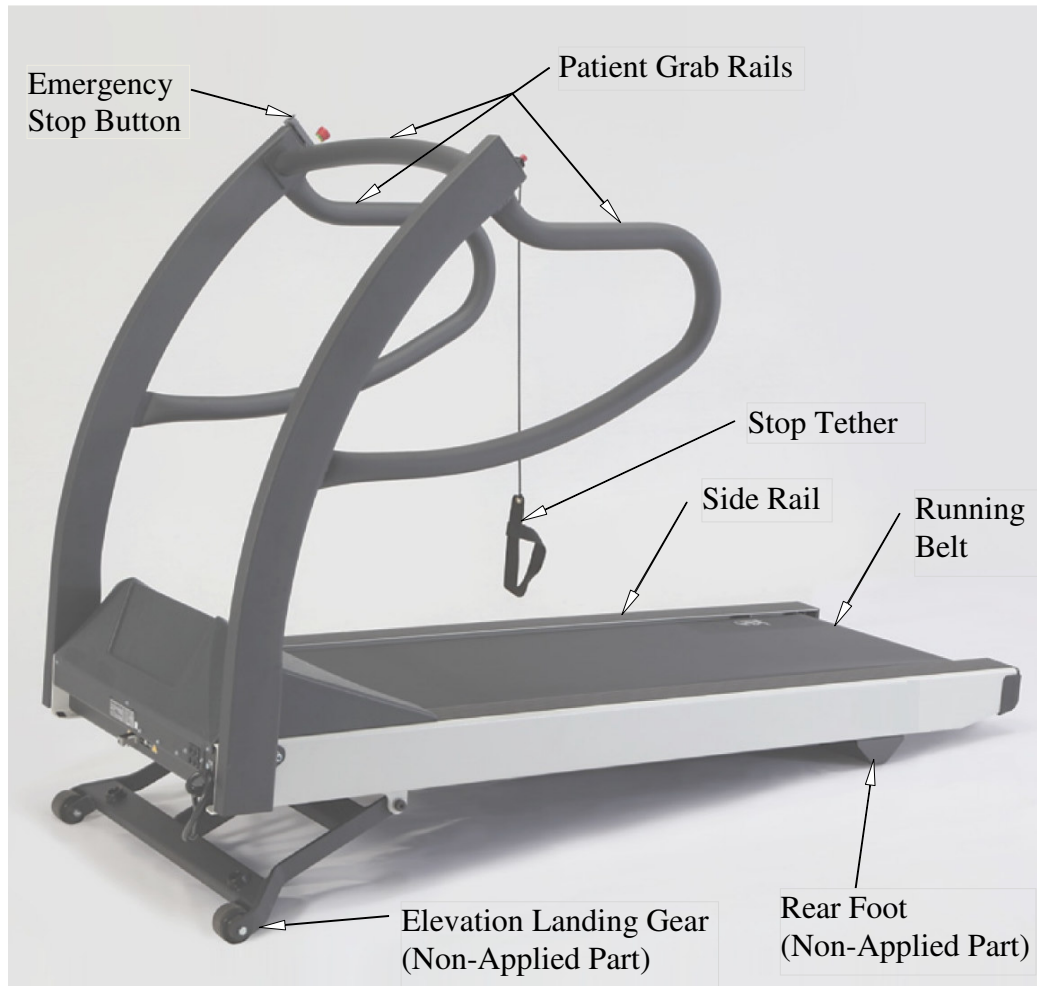

Safety Systems

- Dual comparative speed sensors
- Auto runaway shutdown
- Auto communication loss shutdown
- Manual twist lock Emergency Stop button
- Manual Stop Tether
- Braking system for safe patient offloading
- Fire rated motor pan hood enclosure



TMX428CP Programmable Control

Treadmill

- Patient weight capacity 500 lb., 227 kg
- All steel construction with baked powder-coat finish
- Treadmill net weight: 425 lb., 193 kg

Drive System

- Heavy-duty 6-peak hp. brushless, DC servo motor
- 110-120VAC, 1-phase, 60 Hz, 20-amp power supply (standard)
- 220/240VAC, 1-phase, 50-60 Hz, 15-amp power supply (optional)

Speed Range

- 0.5 to 12 M.P.H., .80 to 19.3 K.P.H., Self-calibrating and adjustable in .1 M.P.H., .1 K.P.H increments. (standard)
- 0.1 to 15 M.P.H., .2 to 24.0 K.P.H., Self-calibrating and adjustable in .1 M.P.H., .1 K.P.H increments. (optional available on TMX428CP only)

Incline Range

- 0 to 25%, .5% incremental movements, Self-calibrating.

Running Surface

- 22in. x 63in. 56cm x 160cm
- MasterTrack[®] running belt tracking system
- cushioned
- Self lubricated and reversible running deck
- Step up height (7 inches., 18cm from floor)

Communication Ports

- RS232 Female Serial port and USB 1.0 “B”

Floor Surface Footprint

- 33in. x 78.5 in., 84cm x 200cm level surface. (See location requirements chapter 5)

Operating and Storage Condition Recommendations

- Operating Temperature Range: 4.5° to +38° C (+40° +85° F)
- Storage Temperature Range: -40° to +70° C (-40° to +158° F)
- Operating and Storage Relative Humidity Range: 10% - 90%, non-condensing
- Altitude: -50 to 5,280 feet

Power Requirements

The TRACKMASTER® is designed to operate on a dedicated 110-120 VAC 20-amp power supply or optional 220/240 VAC 15-amp. Make sure that the treadmill is connected to an outlet that looks like the following illustration.

This product is equipped with a three-wire grounding-type plug. The plug will only fit into a grounding-type outlet. This safety feature must not be disabled. Contact a qualified electrician if you are unable to insert the plug into your outlet, or uncertain if the outlet meets local electrical codes. Polarized outlets such as NEMA 5-20 and CEE7/7 must be verified for proper polarity configuration before plugging in the TRACKMASTER®. Incorrect polarization of the outlet could cause failure of onboard electrical components or cause electrical shock. Proper grounding is necessary for the equipment to meet acceptable current leakage standards consistent with the standards to which it was certified.

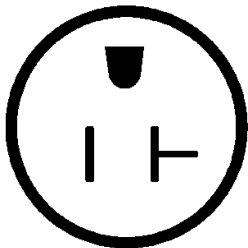

110-120VAC
NEMA 5-20R
Single Phase

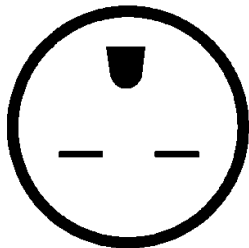

220/240 VAC
NEMA 6-15R
Split Phase

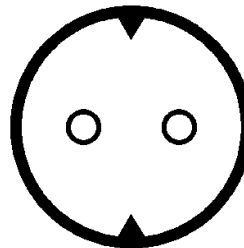

220/240 VAC
CEE 7/7 EURO
Option

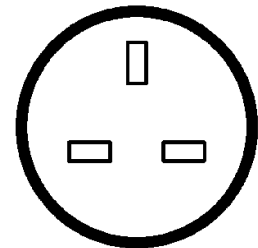

230 VAC
UK BS1363
Option

WARNING



TRACKMASTER® treadmills must be grounded to reduce the risk of electrical shock. If a malfunction occurs, grounding provides a path of least resistance for an electric current. Ungrounded connections must not be used.

No other equipment may be used on the electrical circuit with the TRACKMASTER®. Do not use extension cords. Using a shared or unreliable circuit can also cause the TRACKMASTER® to unexpectedly shut off, potentially resulting in injury to the patient.

Ensure the master power switch is in the off position before plugging in the TRACKMASTER®. A power surge could damage the sophisticated electronic system of the treadmill.

Spécifications électriques

Le TRACKMASTER[®] est conçu pour fonctionner sur un 110-120 VAC alimentation de 20 ampères dédié ou 15 ampères 220/240 VAC en option. Assurez-vous que le tapis roulant est branché sur une prise qui ressemble à l'illustration suivante.

Ce produit est équipé d'une prise de terre à trois fils. La fiche ne peut être insérée dans une prise de terre. Ce dispositif de sécurité ne doit pas être désactivé. Contactez un électricien qualifié si vous ne parvenez pas à insérer la fiche dans la prise, ou incertaine si la sortie répond aux codes électriques locaux. Prises polarisées comme NEMA 5-20 et CEE7 / 7 doivent être vérifiés pour la configuration de la polarité avant de brancher le TRACKMASTER[®]. Polarisation incorrecte de la prise de courant peut provoquer une panne des composants électriques embarqués ou provoquer un choc électrique. Mise à la terre est nécessaire pour l'équipement pour répondre aux normes de fuite de courant acceptable qui soit compatible avec les normes auxquelles elle a été accréditée

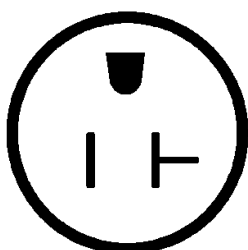

110-120VAC
NEMA 5-20R
Monophasés

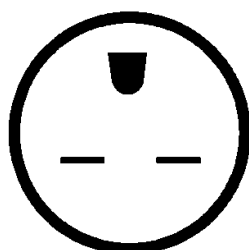

220/240 VAC
NEMA 6-15R
Phase divisée

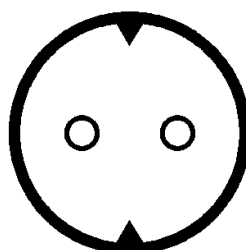

220/240 VAC
CEE 7/7 EURO
Choix

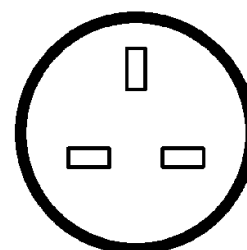

230 VAC
UK BS1363
Choix

AVERTISSEMENT



Tapis roulants TRACKMASTER[®] doivent être mis à la terre pour réduire le risque de choc électrique. En cas de dysfonctionnement, la terre fournit un chemin de moindre résistance pour le courant électrique. Connexions infondées ne doivent pas être utilisées.

Aucun autre équipement ne peut être utilisé sur le circuit électrique avec le TRACKMASTER[®]. Ne pas utiliser de rallonges. L'utilisation d'un circuit partagé ou non fiable peut aussi causer la TRACKMASTER[®]. A fermer de façon inattendue off, ce qui pourrait entraîner des blessures pour le patient.

S'assurer que le commutateur d'alimentation principal est en position arrêt avant de brancher la TRACKMASTER[®]. Une surtension peut endommager le système électronique sophistiqué du tapis roulant.

Hi Pot Test Instructions

4

This test must only be performed by a qualified electrician.

Your Trackmaster® Treadmill has been Hi-Pot tested at the factory just prior to shipment and found to be within specifications. However, some facilities require Hi Pot test verification before the treadmill is put into service. The following instructions must be followed to prevent permanent damage to the Trackmaster® electronic control system. Failure to follow these instructions will void your warranty.

**NEVER USE AN AC HI-POT TESTER ON THIS TREADMILL!
Using an AC HI-Pot tester will permanently damage the DC motor controller board rendering the treadmill inoperable.**

Hi-Pot test instructions for Treadmills

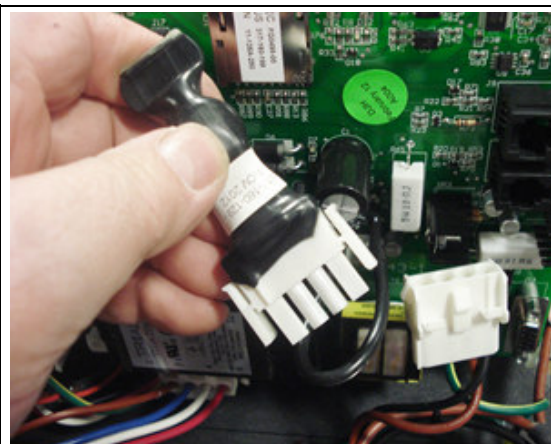

1. Unplug the surge suppressor from the main wire harness.

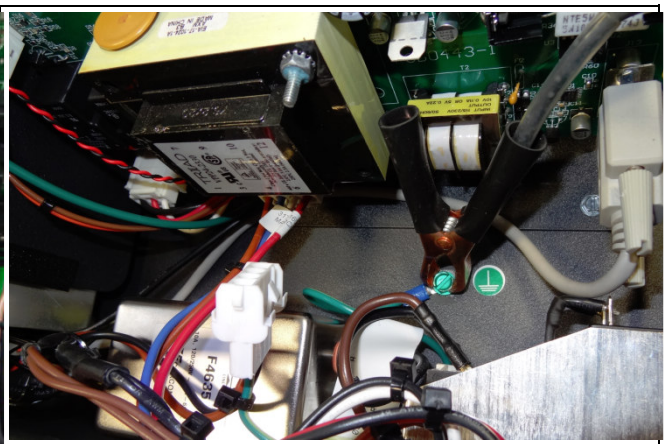

2. Attach DC Hi-Pot tester ground clip to a known chassis ground on the treadmill.



3. For 110V models: Test at 1.75 KV DC for 60 seconds. This is equivalent to 1240 VAC.
4. For 220V models: Test at 2.10 KV DC for 60 seconds. This is equivalent to 1488 VAC.

The tester should register a PASS for either test.

Assembly and Setup

TRACKMASTER® treadmills are shipped fully assembled and packaged in a knock down condition. They are designed to pass through a standard 36" door opening measuring at least 35½". It will be necessary to remove the door from the jam in most cases if the door is not capable of opening fully parallel to door opening. After you have unpacked the treadmill and secured the handrail assembly to the frame, move the treadmill to the area by rolling it on its front wheels. If your treadmill must pass through a door opening less than 36" wide, additional disassembly will be required. This task should be performed by an authorized service provider to ensure that the TRACKMASTER® is properly reassembled and functioning correctly.

Safe Handling Guidelines

- Do not attempt to move the treadmill with the handrails in the shipping condition due to the possibility of cutting the internal wiring. You must either fully secure the handrails in their proper position or remove them.
- Lift the end of the bed assembly to a comfortable height, keeping knees bent and back straight as you lift.
- Rotate the treadmill in the direction you want to go (the treadmill will pivot on its wheels) and push forward.
- When you have maneuvered the treadmill into its location gently lower the end of the bed assembly to the floor.



WARNING



The TRACKMASTER® weight is 425lbs. This requires 2 people to safely remove it from the pallet and locate it in the facility.

If you are moving the treadmill over rough surface, such as pavement, use a dolly under front of the treadmill to prevent damage to the wheels and lift mechanism.

AVERTISSEMENT



Le TRACKMASTER® pèse 193 kg ce qui exige 2 personnes pour le soulever de la palette et l'installer en toute sécurité.

Si vous déplacez le tapis roulant sur une surface rugueuse, comme trottoir, utiliser un chariot sous l'avant du tapis roulant pour éviter d'endommager les roues et mécanisme de levage.

Initial Setup

Tools required for assembly

5/16 Allen wrench (supplied)

2. The treadmill is shipped with the handrails loose, straddling the treadmill frame. It is advised that you secure the handrails in their proper location before removing the treadmill from the base of the crate. This prevents the internal wires running down the handrail mount to the motor pan from being cut.
3. With the help of a 2nd person, swing the handrail assembly into the operating position and insert (2) 3/8-16 bolts and 3/8 lock washer each side and tighten securely.
4. In stall (2) plastic caps each side for a finished look. Figure 5-1

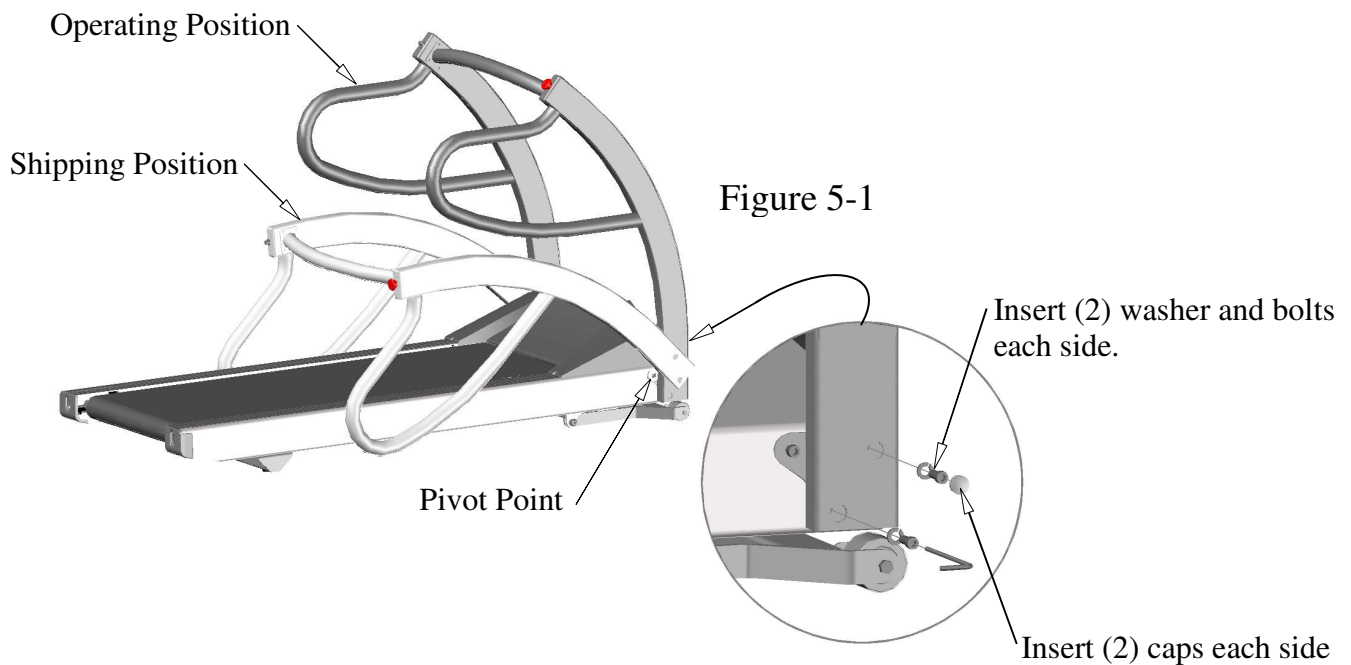

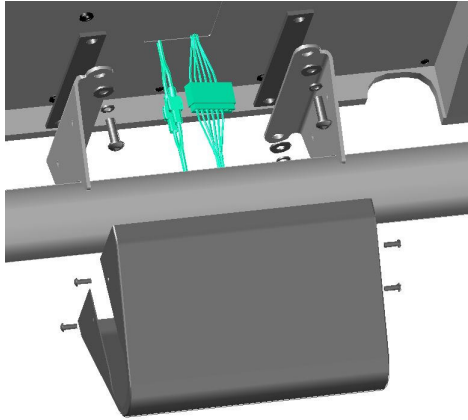
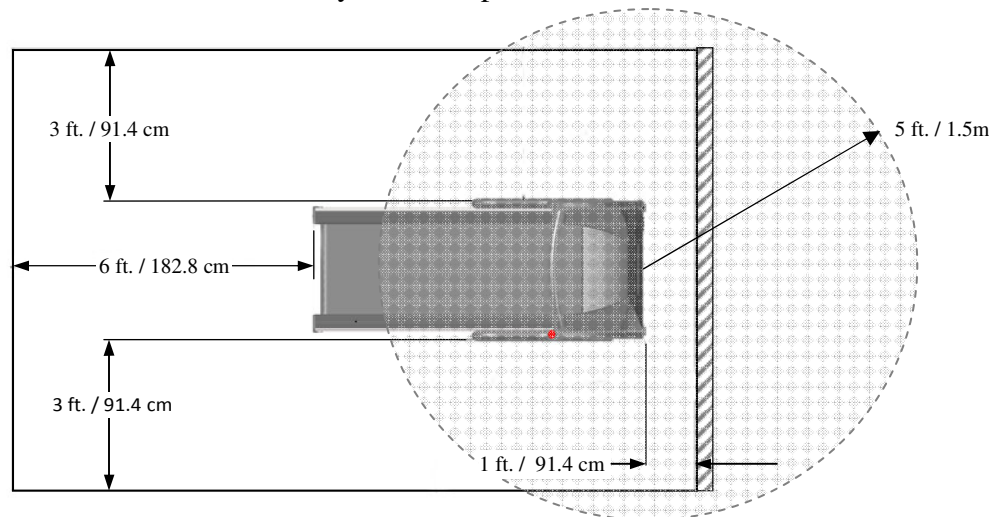

Figure 5-3

4. Connect electrical connections from the back of the console to the connectors within the handrail cross brace.
5. Attached the console to the console supports with the hardware supplied in the order shown in Figure 5-3. Ensure the rubber pads are placed between the steel mounting surface and the back of the console. Tighten bolts evenly.
6. Position the black cover and align the holes in the side of the mount with those in the cover. Secure cover with (4) #10-32 screws.

Location

Place the TRACKMASTER® on a firm and level hard surface that is free of tile grout lines. The illustration below shows the minimum recommended clearances from the treadmill edges to any obstruction for dismount and safety purposes. Observe that the operator should be stationed by the E-Stop.



WARNING



The TRACKMASTER® conforms to FCC class A rating for electromagnetic emissions. It is recommended not to place the treadmill closer than 5ft. (1.5m) from sensitive electronic devices within the room or in an adjacent room. If an interference problem occurs, move the treadmill farther away from the sensitive device or relocate either device to another area, or consult with an EMI specialist for ways to shield the room from electromagnetic radiation.

Do not place it on thick or long-pile carpeting. Such carpeting could cause instability or static build-up, and carpet fibers could get caught in the belt and damage the unit.

Ensure that power cords do not cross traffic areas. Exposed power cords can cause a fall, resulting in injury.

Keep it away from sources of moisture, such as spas or fountains. Moisture can cause the electronic circuitry to malfunction.

AVERTISSEMENT

Le TRACKMASTER® est conforme à FCC classe A d'avis pour les émissions électromagnétiques. Il est recommandé de ne pas placer le tapis roulant à moins de 5 pis. (1.5m) à partir d'appareils électroniques sensibles dans la chambre ou dans une salle adjacente. Si un problème d'interférence, déplacer le tapis roulant plus loin du dispositif sensible ou déplacer soit appareil à un autre domaine, ou consulter un spécialiste EMI des moyens pour protéger la chambre de rayonnement électromagnétique.

Ne le placez pas sur un tapis épais ou longs poils. Un tel tapis pourrait entraîner une instabilité ou accumulation d'électricité statique, et les fibres de tapis pourrait se coincer dans le tapis et endommager l'appareil.

Assurez-vous que les cordons d'alimentation ne traversent pas les zones de circulation. Cordons d'alimentation exposées risqueraient de provoquer une chute, entraînant des blessures.

Tenir à l'écart de toute source d'humidité, comme des spas ou des fontaines. L'humidité peut provoquer le circuit électronique de dysfonctionnement.

Final Setup - Running Belt Tracking Adjustment

NOTE: Because this adjustment is not covered under your warranty, it is important that you review these instructions thoroughly before proceeding. Uneven floors accelerate belt misalignment. This situation may require more frequent adjustment to prevent belt damage.

The patented MasterTrack® Belt Tracking System significantly reduces the need to adjust the belt on your TRACKMASTER®. However, when you operate your treadmill for the first time, you may need to adjust the tracking of the belt to conform to your floor. You may also need to adjust the tracking if you move the machine to another location. (See Preventative Maintenance chapter 7 for adjustment procedure.)

Final Setup - Running Belt Tension Adjustment

Your TRACKMASTER® running belt has been pre-tensioned at the factory and run for 16 hours prior to shipment. It may, however, be necessary to adjust the belt tension when the treadmill is run in its final location. A loose belt tends to hesitate or stick with a heavy foot plant. If your belt needs tensioning, the adjustment procedure can be found in the Preventative Maintenance chapter 7.

NOTE: Improper adjustment could cause the treadmill to hesitate and cause a trip and fall hazard. Because this adjustment is not covered under your warranty, it is important that you review these instructions thoroughly before proceeding.

Final Setup - Drive Belt Tension Adjustment

The drive belt tension has been set at the factory and is self adjusting to minimize maintenance. This design will compensate for initial stretch of the drive belt and not require further adjustment. If the belt becomes stretched and loose, refer to the Preventative Maintenance chapter 7 for adjustment procedure.

NOTE: Because this adjustment is not covered under your warranty, it is important that you review these instructions thoroughly before proceeding.

Final Setup - Test Plug Procedure

Each TRACKMASTER® TMX428 Series treadmill includes an RS-232 test plug that enables you to test the operation of the treadmill without the ECG unit attached. The plug is located on the left side of the treadmill secured to the frame by Velcro. The plug is to be used only for testing the treadmill. Do not stand on or use the treadmill while testing.

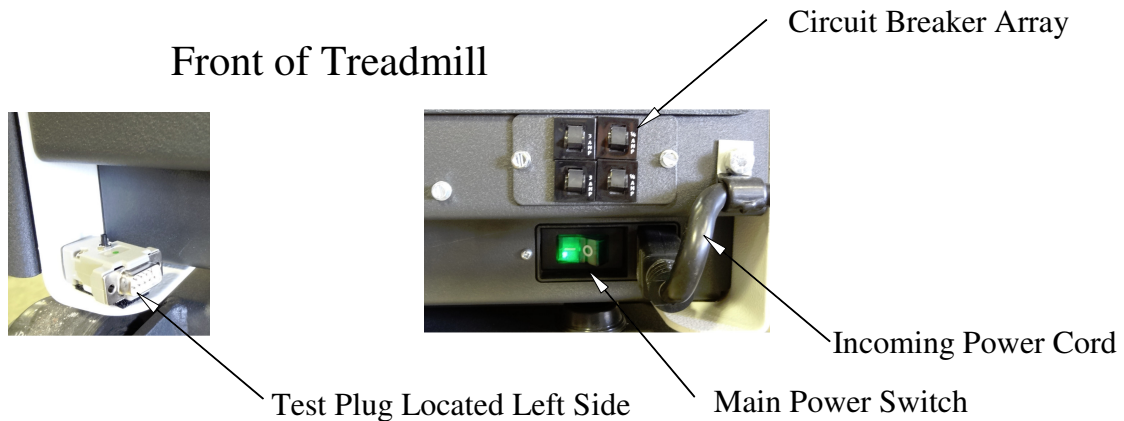

To use the test plug, observe the following procedure:

1. Turn the power "OFF" at the treadmill.
2. Disconnect RS232 or USB interface cable from the treadmill and plug in the test connector.
3. Press and hold the button down on the test connector and turn treadmill power "ON". Continue holding until treadmill begins to elevate.
4. Once this is initiated, each push of the button should elevate the treadmill by 5%.
5. When the treadmill reaches 20% elevation, the next push of the button will start the treadmill running belt.
6. Each push of the button the treadmill will increase speed by 2.5 miles per hour.
7. Once the treadmill reaches 10 mph, each push of the button will bring the speed down 2.5 miles per hour and simultaneously lower the elevation by 5% increments.
8. When minimum speed and elevation is reached the next press of the button will cause the treadmill running belt to stop.

NOTE: Successful completion of the preceding testing procedure ensures that the treadmill is fully functional and responsive to command signals.

9. Remove the test connector.
10. Reconnect the RS232 or USB interface cable from the host computer. You are ready to begin the set-up procedure prescribed by your medical test equipment supplier.

Communication Access Location

The communication ports are located at the very front of the treadmill near the center of the width of the unit. Two ports are offered with equal communication capability. The standard “Female” RS232 port and a new USB “B” port offer connectivity diversification. You will need to install the appropriate USB driver software in order to communicate with the TRACKMASTER®. You may download the appropriate driver based upon your computer OS at <http://www.ftdichip.com/Drivers/VCP.htm>. When connecting to the USB port, ensure port configuration is congruent with your software port identification.

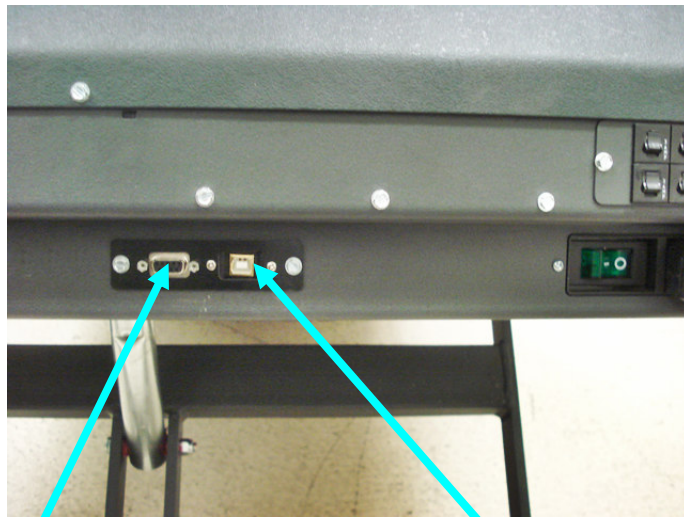

RS232 Port
“Female”

USB “B” Port

Programmable Control Instructions

TMX428CP

6

The TRACKMASTER® TMX428CP Programmable Control model is a dual purpose treadmill capable of running in diagnostic mode for cardiac stress testing or a VO₂ pulmonary evaluation. The display automatically changes from a blue, full information screen typically found on fitness treadmills, to a black screen with minimal status data upon initiating a test program within a 3rd party diagnostic computer system. All control buttons in the console are disabled in this mode with the exception of the two stop buttons located at the lower left and lower right of the control. The display will revert back to the full information screen upon closing the diagnostic computer program.

DIAGNOSTIC TESTING MODE DISPLAY

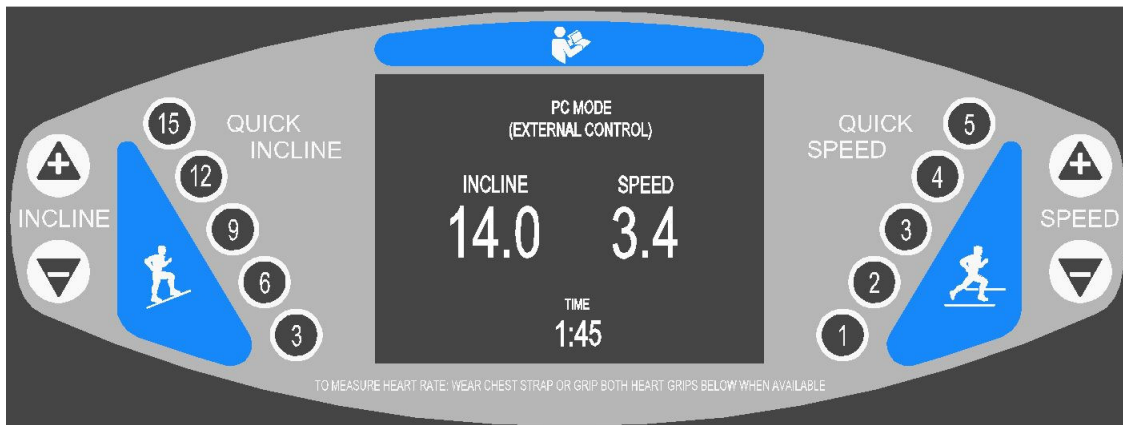

The TRACKMASTER® TMX428CP Programmable Control model is full-featured, stand-alone fitness treadmill suitable for rehabilitation and general fitness applications. Additionally, it comes pre-programmed with 10 workouts including Pre-Programmed Protocols and Interval Fitness training routines in addition to 5 possible user defined workouts.

MANUAL MODE DISPLAY



Control Panel Display: The blue display screen in the center of the console provides information on how to begin your workout and provides continuous user performance data throughout the workout session. Additionally, it serves as a user interface allowing optional input of user information when a new workout begins. The screen will prompt the user to input weight, age, and gender so that the onboard computer can calculate a more accurate calorie burn and target heart rate. Heart rate measurement is accessible through the use of the contact grips or by wearing a wireless pulse rate watch or chest strap. The display screen allows the user to simultaneously monitor; time, speed, incline, distance traveled, pace, current heart rate, calories burned and METS.

The performance and feedback information provide on the blue display screen are defined as follows:

Time: The elapsed time of your workout session beginning with the initial movement of the belt and ending when the stop buttons are pressed.

Speed: The speed at which the belt is moving. The belt starts at .1 M.P.H. and has a top speed of 15 M.P.H. Belt speed can be increased or decreased in .1 M.P.H. increments. This feature is capable of displaying KPH.

Incline: The degree of incline of the walking surface. The starting incline is 0% and a maximum of 25%. The degree of incline can be increased or decreased in .5% increments.

Distance: The distance traveled in miles during the duration of the workout session beginning with the initial movement of the belt and ending when the stop buttons are pressed. The distance is measured in .1 of a mile. This feature is capable of displaying in Kilometers.

Heart Rate: The user's current heart rate calculated in beats per minute when wearing a wireless chest strap, wireless watch monitor, or by using the contact grips.

Calories: An approximate calculation of cumulative K-CAL expenditure for the exercise session based on your body weight and the level of difficulty at which you are exercising.

Pace: Displays the number of minutes needed to run one mile or kilometer.

METS: Displays MET level

Control Panel Button Descriptions:

NOTE: You must attach the Stop Tether lanyard strap to your wrist before pressing any other buttons on the TRACKMASTER® control. The lanyard will stop the moving running belt should you fall.

Stop Tether: This switch is located on the console in the lower right hand portion, just right of center. It is used in combination with a lanyard and wrist cuff which is to be worn by the user at all times during the operation of the TRACKMASTER®. The opposite end of the lanyard has a plastic "C" shaped piece that engages the Stop Tether which must be in place for the machine to run. Simply insert the clip on the shaft directly behind the red cap on the switch. The TRACKMASTER® is designed to stop all functions upon activation of the Stop Tether. Operation cannot resume until "C" shaped clip is returned to its operational position.



Start button: The green start button is used to begin a workout session. When a new user steps onto the machine and the start up information is displayed on the screen, pressing the start button will immediately begin a 3 second countdown of the belt start at minimum belt speed. When a user has previously selected a pre-programmed workout, pressing the start button will start the first phase of the program.

Stop buttons: The red hexagon shaped stop buttons are used to end an exercise session. Anytime that it is pressed during a workout session, the running belt will gently come to a stop and be locked into place for 2 minutes or until a new workout session is started. Upon pressing the stop button, the incline of the running deck will decrease to 0 percent and the cumulative user data information will be displayed for 60 seconds. To start a new workout session, press Start button or Program button.

Enter button: The yellow enter button is used to enter the user's weight, age, and gender when prompted by the display screen at the beginning of a workout session as well as entering data when creating or modifying workout programs.

Cool Down button: The blue cool down button will incrementally slow the running belt speed down by .1 mph or kph and decrease elevation by .5% elevation incrementally over 90 seconds every until the running belt stops and elevation to 0% elevation.

Program / Select button: The black program button calls up a list of pre-programmed workouts and is used to select segments of a workout when creating or modifying a workout routine.

Speed Slower: The triangular speed minus button decreases the speed of the running belt by .1 mph or kph each time it is pressed while the belt is moving. Pressing and holding the speed slower button while the belt is moving will decrease the speed of the running belt at an accelerated rate until it is released.

Speed Faster: The triangular speed faster button increases the speed of the running belt by .1 mph or kph each time it is pressed while the belt is moving. Pressing and holding the speed faster button while the belt is moving will increase the speed of the running belt at an accelerated rate until it is released.

Quick Speed: The (5) quick speed buttons will rapidly bring the running belt speed to the selected speed selected from 1 to 5 mph or K.P.H.

Incline Minus: The triangular incline minus button decreases the incline of the walking surface by .5 percent each time it is pressed while the running belt is operating. Pressing and holding the incline minus button while the running belt is in motion will increase the rate of the command. However, it may take a few seconds to reach the desired incline that is displayed on the information screen after the button is released.

Incline Plus: The triangular incline plus button increases the incline of the walking surface by .5 percent each time it is pressed while the running belt is operating. Pressing and holding the incline plus button while the running belt is in motion will increase the rate of the command. However, it may take a few seconds to reach the desired incline that is displayed on the information screen after the button is released.

Quick Incline: The (5) quick incline buttons will rapidly bring the running belt surface to the selected incline from 3 to 15 percent.

WORKOUT GRAPHICS

<ol style="list-style-type: none"> 1. The entire workout is represented in the form of a colored bar graph which depicts increasing workout intensity as well as workout progression and current treadmill settings. These values can be displayed in either Metric or English measurements. 2. Segments that have been completed will turn to MAGENTA. In the example above, the first two segments of the workout have been completed leaving (7) segments yet to complete. 3. The GREEN portion of the bar represents an incline between 0 and 10% 4. The YELLOW portion of the bar represents an incline between 10% and 18%. 5. The RED portion of the bar represents an incline from 18% to 25%. 6. The BLACK horizontal bars represent the running belt speed. They will turn to WHITE when the segment is completed. 		

MANUAL OPERATION:

The default start-up screen allows the user to bypass the user data by simply pressing the START button. To enter user data, complete steps 1-16. The user interface screen easily leads the user through the appropriate steps to achieve a desired operation.

<ol style="list-style-type: none"> 1. Press the ENTER button to input user information. 2. Optionally, press the START button to start the treadmill in a non-defined run mode. OR- 3. Press the PROGRAM SELECT button to view and select a Built-In routine. Go to step 15. 	<p>PRESS "ENTER" ● TO INPUT USER INFORMATION</p> <p>PRESS "START" ● TO BEGIN EXERCISE ROUTINE</p> <p>PRESS "PROGRAM SELECT" ● TO BEGIN PROGRAM EXERCISE ROUTINE</p>
<p>If you opted to input your user information, follow the next 12 steps</p> <ol style="list-style-type: none"> 4. Press the + or – button until the desired age appears on the screen. 5. Press the ENTER button to continue. 	<p>PRESS ▲ OR ▼ BUTTON TO INPUT YOUR AGE THEN PRESS "ENTER" ●</p> <p style="font-size: 2em; font-weight: bold;">40</p>

<p>6. Press the + or – button until the desired weight appears on the screen. 7. Press the ENTER button to continue.</p>	
<p>8. Press the + or – button until the correct gender appears on the screen. 9. Press the ENTER button to continue.</p>	
<p>10. Press the + or – button until the desired heart rate appears on the screen. 11. Press START to begin walking.</p> <p>NOTE: The target heart rate function is only available through the use of a wireless chest strap or pulse rate watch monitoring device.</p>	
<p>NOTE: If the user exceeds the stated heart rate target, the screen will flash a warning that the target heart rate has been exceeded. The treadmill, however, will not stop. It is the responsibility of the user to take further action.</p>	
<p>12. Upon pressing the START button in step 11, the screen will advise that the belt will start in a countdown of 3 as shown at the right.</p>	
<p>13. After the belt begins to move, elevation and speed control is available through the use of the + / - keys as well as the quick speed keys on the console. 14. Press the STOP key to immediately stop your workout or press COOL DOWN key to slowly decelerate the belt to a stop.</p>	

BUILT-IN PROGRAM OPERATION

There are 10 pre-programmed workouts within the control. Select from Five Pre-Programmed protocols and (5) interval training routines. To access these programs, complete the following steps: The following (5) Pre-Programmed Protocols are explained here.

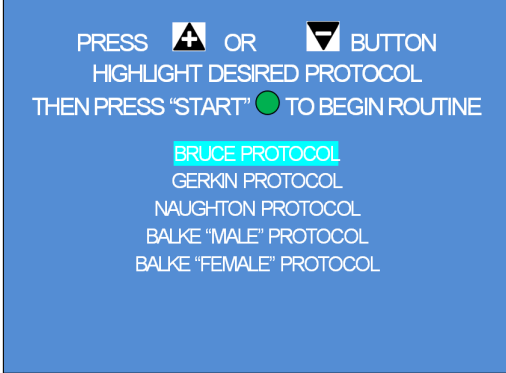
<p>15. In Step 3, the user selected the PROGRAM SELECT button to access Built-In program routines. This screen requires the user to select either Pre-Programmed Protocols, Fitness Interval workouts, or to define a custom works by utilizing the + - buttons. When the desired program is highlighted, press the Yellow Enter button to select. If the user selects Fitness Workouts, go to Step 17. If the user selects the User Defined Program go to Step 19.</p>	
<p>16. Press the + or – button until the desired Protocol is selected. When the desired program is highlighted, press the Green Start button to start routine. The detailed description for each Pre-Programmed Protocol to follow.</p>	

Pre-Programmed Protocol Workout Data

Bruce Protocol

	Time	Speed		Incline
		KPM / MPH		
Warm-up	3 min	2.7	1.7	0%
Stage 1	3 min	2.7	1.7	10%
Stage 2	3 min	4.0	2.5	12%
Stage 3	3 min	5.7	3.4	14%
Stage 4	3 min	6.8	4.2	16%
Stage 5	3 min	8.1	5.0	18%
Stage 6	3 min	8.9	5.5	20%
Stage 7	3 min	8.9	6.0	22%
Cool-down	3 min	2.7	1.7	0%

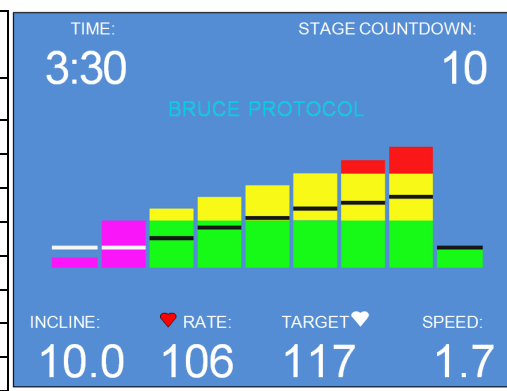

Gerkin Protocol (Firefighter's Test)

	Time	Speed		Incline
		KPM / MPH		
Warm-up	3 min	4.8	3.0	0%
Stage 1	1 min	7.2	4.5	0%
Stage 2	1 min	7.2	4.5	2%
Stage 3	1 min	8.0	5.0	2%
Stage 4	1 min	8.0	5.0	4%
Stage 5	1 min	8.8	5.5	4%
Stage 6	1 min	8.8	5.5	6%
Stage 7	1 min	9.7	6.0	6%
Stage 8	1 min	9.7	6.0	8%
Stage 9	1 min	10.5	6.5	8%
Stage 10	1 min	10.5	6.5	10%
Stage 11	1 min	11.3	7.0	10%
Stage 12	1 min	11.3	7.0	12%
Stage 13	1 min	12.0	7.5	12%
Stage 14	1 min	12.0	7.5	14%
Stage 15	1 min	12.9	8.0	14%
Stage 16	1 min	12.9	8.0	16%
Cool-down	3 min	2.7	1.7	0%

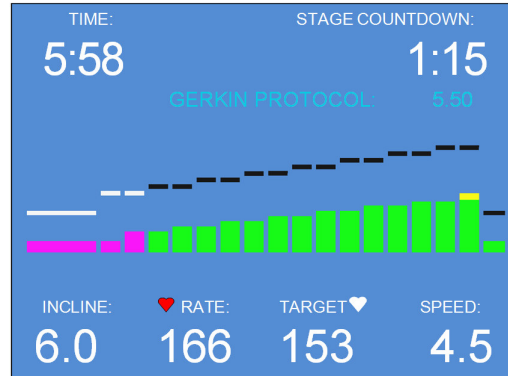

Naughton Protocol

	Time	Speed		Incline
		KPM / MPH		
Warm-up	2 min	1.6	1.0	0%
Stage 1	2 min	3.2	2.0	0%
Stage 2	2 min	3.2	2.0	3.5%
Stage 3	2 min	3.2	2.0	7.0%
Stage 4	2 min	3.2	2.0	10.5%
Stage 5	2 min	3.2	2.0	14.0%
Stage 6	2 min	3.2	2.0	17.5%
Cool-down	3 min	1.6	1.0	0%

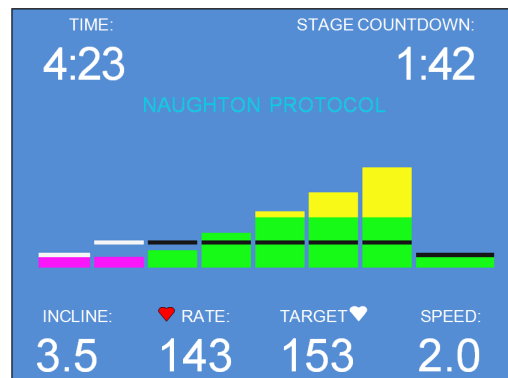

Balke- Male

	Time	Speed		Incline
		KPM / MPH		
Warm-up	2 min	2.7	1.7	0%
Stage 1	1 min	5.3	3.3	0%
Stage 2	1 min	5.3	3.3	2%
Stage 3	1 min	5.3	3.3	3%
Stage 4	1 min	5.3	3.3	4%
Stage 5	1 min	5.3	3.3	5%
Stage 6	1 min	5.3	3.3	6%
Stage 7	1 min	5.3	3.3	7%
Stage 8	1 min	5.3	3.3	8%
Stage 9	1 min	5.3	3.3	9%
Stage 10	1 min	5.3	3.3	10%
Stage 11	1 min	5.3	3.3	11%
Stage 12	1 min	5.3	3.3	12%
Stage 13	1 min	5.3	3.3	13%
Stage 14	1 min	5.3	3.3	14%
Stage 15	1 min	5.3	3.3	15%
Stage 16	1 min	5.3	3.3	16%
Stage 17	1 min	5.3	3.3	17%
Stage 18	1 min	5.3	3.3	18%
Stage 19	1 min	5.3	3.3	19%
Stage 20	1 min	5.3	3.3	20%
Stage 21	1 min	5.3	3.3	21%
Stage 22	1 min	5.3	3.3	22%
stage 23	1 min	5.3	3.3	23%
stage 24	1 min	5.3	3.3	24%
Stage 25	1 min	5.3	3.3	25%
Cool-Down	3 min	2.7	1.7	0%

TIME: 6:28STAGE COUNTDOWN: 0:37

BALKE PROTOCOL (MALE)

INCLINE: 5.0
♥ RATE: 123
TARGET ♥ 153
SPEED: 3.3

Balke- Female

	Time	Speed		Incline
		KPH / MPH		
Warm-up	2 min	2.7	1.7	0%
Stage 1	1 min	4.8	3.0	0%
Stage 2	1 min	4.8	3.0	2.5%
Stage 3	1 min	4.8	3.0	5.0%
Stage 4	1 min	4.8	3.0	7.5%
Stage 5	1 min	4.8	3.0	10%
Stage 6	1 min	4.8	3.0	12.5%
Stage 7	1 min	4.8	3.0	15.0%
Stage 8	1 min	4.8	3.0	17.5%
Stage 9	1 min	4.8	3.0	20.0%
Stage 10	1 min	4.8	3.0	22.5%
Stage 11	1 min	4.8	3.0	25.0%
Cool-Down	3 min	2.7	1.7	0%

TIME: 6:18STAGE COUNTDOWN: 2:47

BALKE PROTOCOL (FEMALE)

INCLINE: 2.5
♥ RATE: 143
TARGET ♥ 153
SPEED: 3.0

Pre-Programmed Fitness Workout Data

17. To access Pre-Programmed Fitness Workouts, use the + / - key to highlight the selection and press the Yellow Enter button.

PRESS  OR  BUTTON TO HIGHLIGHT DESIRED PROGRAM THEN PRESS "ENTER" 



18. The screen at the right shows the (5) Fitness workouts the user can choose from. Select the desired Fitness Workout by pressing the + / - button then press the Yellow Enter button to input user information or press the Green Start button to begin workout.

PRE-PROGRAMMED PROTOCOLS

FITNESS WORKOUTS

USER DEFINED PROGRAM

NOTE: Any of the Fitness Interval Training programs can be altered in intensity merely by pressing + / - for belt speed or Incline. The control will remember that setting as it transitions from one segment to the next.

PRESS  OR  BUTTON TO HIGHLIGHT DESIRED PROGRAM THEN PRESS "ENTER"  TO SELECT

INTERVAL WORKOUT

SPEED INTERVAL WORKOUT
HIGH INTENSITY SPEED INTERVAL WORKOUT
PEEK INTERVAL WORKOUT
HIGH INTENSITY PEEK INTERVAL WORKOUT

INTERVAL WORKOUT

	Time	Speed		Incline
		KPH	MPH	
Warm-up	1.5 min	4.8	3.0	0%
Stage 1	1.5 min	5.6	3.5	5%
Stage 2	1.5 min	4.8	3.0	2%
Stage 3	1.5 min	5.6	3.5	7%
Stage 4	1.5 min	4.8	3.0	5%
Stage 5	1.5 min	5.6	3.5	9%
Stage 6	1.5 min	4.8	3.0	5%
Stage 7	1.5 min	5.6	3.5	12%
Stage 8	1.5 min	4.8	3.0	5%
Stage 9	1.5 min	5.6	3.5	12%
Cool-Down	3.0 min	4.8	3.0	0%

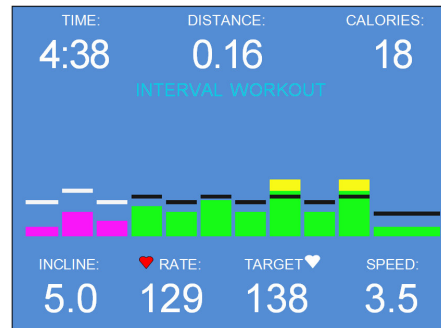

SPEED INTERVAL WORKOUT

	Time	Speed		Incline
		KPH	MPH	
Warm-up	1.5 min	4.0	2.5	0%
Stage 1	0.5 min	6.4	4.0	0%
Stage 2	1.5 min	4.0	2.5	0%
Stage 3	0.5 min	6.4	4.0	0%
Stage 4	1.5 min	4.0	2.5	0%
Stage 5	0.5 min	6.4	4.0	0%
Stage 6	1.5 min	4.0	2.5	0%
Stage 7	0.5 min	6.4	4.0	0%
Stage 8	1.5 min	4.0	2.5	0%
Stage 9	0.5 min	6.4	4.0	0%
Stage 10	1.5 min	4.0	2.5	0%
Stage 11	0.5 min	6.4	4.0	0%
Stage 12	1.5 min	4.0	2.5	0%
Stage 13	0.5 min	6.4	4.0	0%
Stage 14	1.0 min	4.0	2.5	0%
Cool-Down	3.0 min	3.2	2.0	0%

Summary screen for Speed Interval Workout. It displays a progress bar at the top with segments in white, pink, green, and black. Below the bar, the following metrics are shown: TIME: 5:25, DISTANCE: 0.27, CALORIES: 22. At the bottom, INCLINE: 0.0, RATE: 128 (with a red heart icon), TARGET: 146 (with a white heart icon), and SPEED: 4.0.

HIGH INTENSITY SPEED INTERVAL WORKOUT

	Time	Speed		Incline
		KPH	MPH	
Warm-up	1.5 min	4.0	2.5	0%
Stage 1	1.5 min	6.4	4.0	0%
Stage 2	0.5 min	4.0	2.5	0%
Stage 3	1.5 min	6.4	4.0	0%
Stage 4	0.5 min	4.0	2.5	0%
Stage 5	1.5 min	6.4	4.0	0%
Stage 6	0.5 min	4.0	2.5	0%
Stage 7	1.5 min	6.4	4.0	0%
Stage 8	0.5 min	4.0	2.5	0%
Stage 9	1.5 min	6.4	4.0	0%
Stage 10	0.5 min	4.0	2.5	0%
Stage 11	1.5 min	6.4	4.0	0%
Stage 12	0.5 min	4.0	2.5	0%
Stage 13	1.5 min	6.4	4.0	0%
Stage 14	1.0 min	4.0	2.5	0%
Cool-Down	3.0 min	3.2	2.0	0%

Summary screen for High Intensity Speed Interval Workout. It displays a progress bar at the top with segments in white, pink, green, and black. Below the bar, the following metrics are shown: TIME: 5:38, DISTANCE: 0.42, CALORIES: 35. At the bottom, INCLINE: 0.0, RATE: 143 (with a red heart icon), TARGET: 146 (with a white heart icon), and SPEED: 4.0.

PEAK INTERVAL WORKOUT

	Time	Speed		Incline
		KPH / MPH		
Warm-up	1.5 min	4.0	2.5	0%
Stage 1	0.5 min	6.4	4.0	5%
Stage 2	1.5 min	4.0	2.5	3%
Stage 3	0.5 min	6.4	4.0	5%
Stage 4	1.5 min	4.0	2.5	3%
Stage 5	0.5 min	6.4	4.0	5%
Stage 6	1.5 min	4.0	2.5	3%
Stage 7	0.5 min	6.4	4.0	7%
Stage 8	1.5 min	4.0	2.5	5%
Stage 9	0.5 min	6.4	4.0	9%
Stage 10	1.5 min	4.0	2.5	7%
Stage 11	0.5 min	6.4	4.0	12%
Stage 12	1.5 min	4.0	2.5	10%
Stage 13	0.5 min	6.4	4.0	12%
Stage 14	1.0 min	4.0	2.5	3%
Cool-Down	3.0 min	3.2	2.0	0%

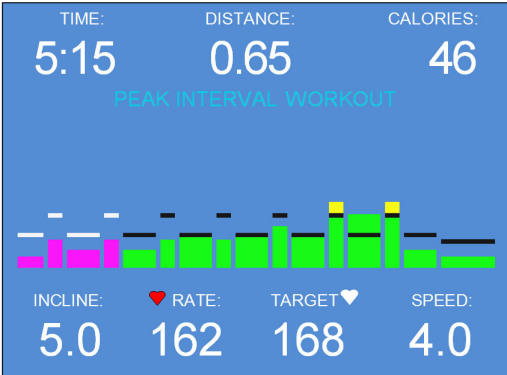

HI INTENSITY PEAK INTERVAL WORKOUT

	Time	Speed		Incline
		KPM / MPH		
Warm-up	1.5 min	4.0	2.5	0%
Stage 1	1.5 min	6.4	4.0	5%
Stage 2	0.5 min	4.0	2.5	3%
Stage 3	1.5 min	6.4	4.0	5%
Stage 4	0.5 min	4.0	2.5	3%
Stage 5	1.5 min	6.4	4.0	5%
Stage 6	0.5 min	4.0	2.5	3%
Stage 7	1.5 min	6.4	4.0	7%
Stage 8	0.5 min	4.0	2.5	5%
Stage 9	1.5 min	6.4	4.0	9%
Stage 10	0.5 min	4.0	2.5	7%
Stage 11	1.5 min	6.4	4.0	12%
Stage 12	0.5 min	4.0	2.5	10%
Stage 13	1.5 min	6.4	4.0	12%
Stage 14	1.0 min	4.0	2.5	3%
Cool-Down	3.0min	3.2	2.0	0%

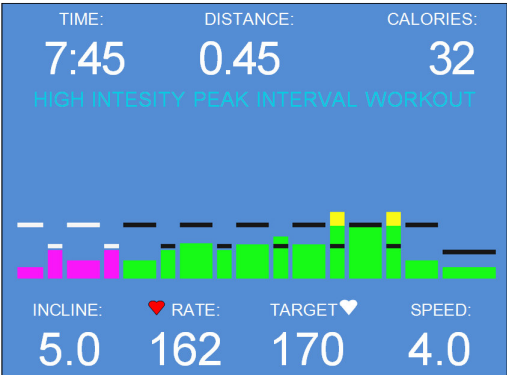



User Defined Programming

19. To access User Defined menu, use the + / - key to highlight the selection and press the Yellow enter button.

NOTE: Any of the User Defined Programs can be altered in intensity merely by pressing + / - for belt speed or Incline. The computer will remember that setting as it transitions from one segment to the next.

20. The screen at the right shows the (5) Custom Workouts the user can choose from. The control has room for 10. There may be none in memory. Select the desired Custom Workout by pressing the + / - button then press the Green Start button to begin or press the Yellow Enter button to modify an existing workout. If no workouts exist and you press the Start button, Screen 21 will appear.



21. Press the + / - buttons to input the variables a field. Make sure your variable value is correct before pressing the Black Program Select button. Upon pressing this button. The cursor will advance to the next variable field. Repeat the steps above for all 3 fields. Press the Green Start button to save the routine.

PRESS  OR  BUTTON
TO HIGHLIGHT DESIRED PROGRAM
THEN PRESS "ENTER" 

PRE-PROGRAMMED PROTOCOLS

FITNESS WORKOUTS

USER DEFINED PROGRAM

PRESS  OR  BUTTON
HIGHLIGHT DESIRED PROGRAM
THEN PRESS "START"  TO BEGIN ROUTINE

CUSTOM WORKOUT 1



CUSTOM WORKOUT 2

CUSTOM WORKOUT 3

CUSTOM WORKOUT 4

CUSTOM WORKOUT 5

TO MODIFY EXISTING PROGRAM
SELECT "ENTER" 

PRESS  OR  BUTTON
TO SET TIME, ELEVATION, SPEED
PRESS "PROGRAM SELECT"  TO
ADVANCE AFTER EACH INPUT

STAGE 1 OF 10

TIME (SECONDS):	000
ELEVATION (% GRADE):	00.0
SPEED (MPH):	00.0

THEN PRESS "START"  TO SAVE

Preventive Maintenance

Regular cleaning and maintenance is essential to keep your TRACKMASTER® operating at its best for many years. We recommend that you record all maintenance and service in a log (as shown in Appendix A).



Before cleaning the TRACKMASTER® turn the main power switch to OFF, and disconnect the treadmill from its power outlet. Never use wet cleaning materials near a power source: you could suffer an electrical shock.



Avant de nettoyer le TRACKMASTER® placez l'interrupteur principal sur la position OFF (ARRET), puis débranchez le cordon d'alimentation de la prise électrique. Ne jamais utiliser des solvants liquides ou des chiffons mouillés près d'une source électrique: vous pourriez souffrir d'un choc électrique.

To preserve the condition of your warranty, make sure that all repair procedures (other than normal maintenance) are performed by an authorized and qualified service provider. Contact customer support with any questions at (316) 283-3344.

Use only TRACKMASTER® replacement parts. Using other parts may void your warranty and may cause your TRACKMASTER® to malfunction.

Daily Maintenance

- Wipe the treadmill to remove soil, moisture, and perspiration.
- Clean the hood and handrails with a soft cloth, dampened with a solution of warm water and mild detergent.
- Do not use harsh chemicals on the LCD screen.
- Remove stubborn stains and scuff marks with a nonabrasive, industrial strength cleaner, such as Formula 409®. Spray all cleaners on a terrycloth-type cloth: avoid spraying cleaner directly onto the treadmill.
- Ensure that the treadmill is functioning properly.

Weekly Maintenance

- Vacuum around and under the treadmill. Clean all exposed surfaces with a vacuum cleaner. Avoid moving the TRACKMASTER® from its original position moving it will compromise the original belt tracking setting.
- Check running belt tension.
- Observe running belt tracking, correct as required.

Monthly Maintenance

- Belt cleaning and inspection.

Semiannual Maintenance

- Evaluate the condition of the deck and belt.
- Belt adjustment needs to be performed to assure proper belt alignment.
- Check running belt adjustment.
- Check drive belt tension adjustment.
- Clean and lubricate the treadmill elevation screw.

NOTE: Use only TRACKMASTER® replacement parts. Using other parts may void your warranty and may cause your TRACKMASTER® to malfunction.

Belt Cleaning and Inspection

1. Turn treadmill main power switch ON.
2. Start treadmill at .5 mph. With a damp small towel wipe excessive dirt from running belt keeping the towel in the center of the length of the treadmill. Avoid getting the towel near the rear roller.
3. When belt is clean stop treadmill.
4. Inspect running belt for tears or nicks. If damaged, replace the belt.
5. Perform Running Belt Tracking Adjustment and Belt Tension Adjustment.

Running Belt Tracking Adjustment

This procedure requires the following tool:

- 1/4-in. Allen wrench

NOTE: Because this adjustment is not covered under your warranty, it is important that you review these instructions thoroughly before proceeding.

The patented MasterTrack® Belt Tracking System significantly reduces the need to adjust the belt on your TRACKMASTER®. However, when you operate your TRACKMASTER® for the first time, you may need to adjust the tracking of the belt to conform to your floor. You may also need to adjust the tracking if you move the machine to another location.

Your running belt should remain centered, although a slight amount of movement to the left or right is normal during use. Do not allow the running belt to travel all the way to either side.

To adjust the belt tracking, do the following:

1. Turn the treadmill's power switch to ON.
2. Increase the speed to 3 mph.
3. Observe the left side of the running belt as it travels over the rear roller. If the belt runs to the right side of the roller, turn the right bolt one-eighth turn clockwise, and turn the left bolt one-eighth turn counterclockwise.

NOTE: When tightening one side of the belt, always loosen the opposite side one-half as much. This procedure provides finer control, with a smaller impact on the belt tension.

Check the belt after 2 minutes, with the treadmill running at approximately 7 mph. If the belt does not correct itself, continue with slight turns until the belt is in the center of the rear roller. If the belt runs toward the left side of the roller reverse the adjustments.

NOTE: Uneven floors accelerate belt misalignment. This situation may require more frequent adjustment to prevent belt damage.

Running Belt Tension Adjustment

The running belt may stretch and loosen with regular use. This looseness is noticeable when the belt tends to hesitate or stick. Adjust the tension on the belt by following the procedure and referring to the illustration below.

1. Turn the treadmill's power switch to ON.
2. Start treadmill and increase to 1 mph
3. Start walking on the treadmill, grab side handrail and apply pressure with your foot to create resistance on running belt.
4. If running belt hesitates or slips on front drive roller, tighten both tension bolts $\frac{1}{2}$ turn (Clockwise).
5. Repeat steps 2 thru 4 until running belt stop slipping.

NOTE: When running belt is too tight the edge of belt will curl causing premature running belt failure.

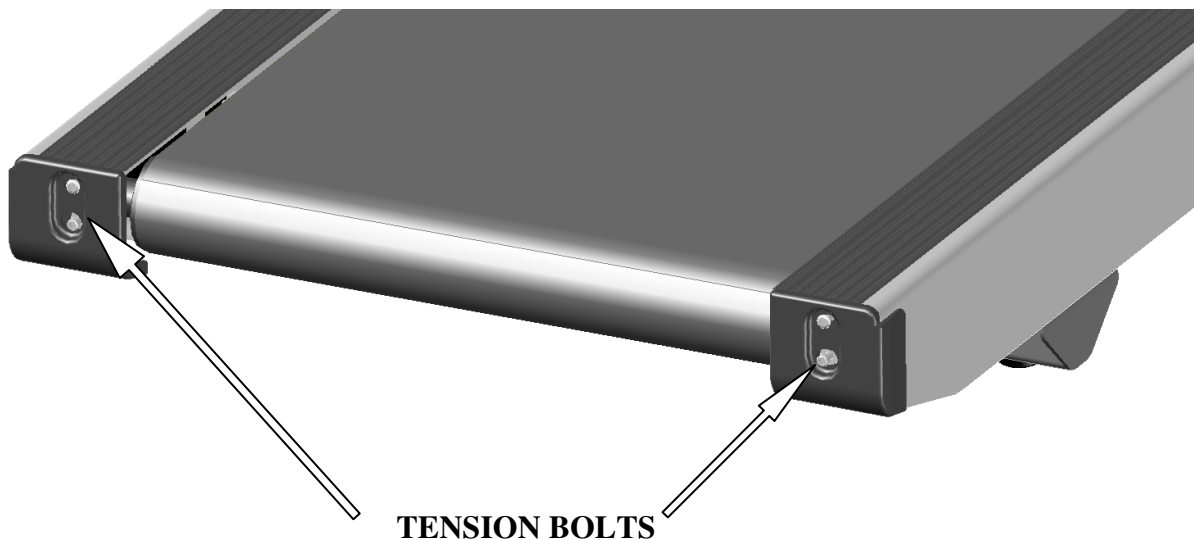

Drive Belt Tension Adjustment

This procedure requires the following tool:

- $\frac{1}{8}$ " Allen Wrench
- $\frac{3}{4}$ " Socket or Box Wrench
- $\frac{3}{4}$ " Wrench
- Tape measure

NOTE: Because this adjustment is not covered under your warranty, it is important that you review these instructions thoroughly before proceeding.

NOTE: The drive belt may stretch and loosen with regular use. This looseness may result in a flapping noise under the hood.

1. MAKE SURE THE TREADMILL IS SWITCHED TO THE OFF POSITION AND DISCONNECTED FROM ITS POWER OUTLET.
2. Remove the (3) #10-32 screws located on the bottom hood with $\frac{1}{8}$ " Allen wrench.
3. With the $\frac{3}{4}$ " socket and wrench loosen the TENSION ADJUSTMENT back nut.
4. Measure from the head of the $\frac{1}{2}$ "-13 bolt to the motor housing. The spring compression should be $1\text{-}\frac{3}{16}$ " or 30mm.
5. Using a $\frac{3}{4}$ " wrench turn the TENSION BOLT clockwise to compress the spring. To decrease compression, turn the wrench counter clockwise.
6. When the spring is compressed to $1\text{-}\frac{3}{16}$ " or 30mm, tighten the TENSION ADJUSTMENT back nut.

NOTE: Failure to lock the TENSION ADJUSTMENT Back Nut will allow the drive belt tension to become loose.

7. When the treadmill is properly adjusted reinstall hood with (3) each #8-32 screws.

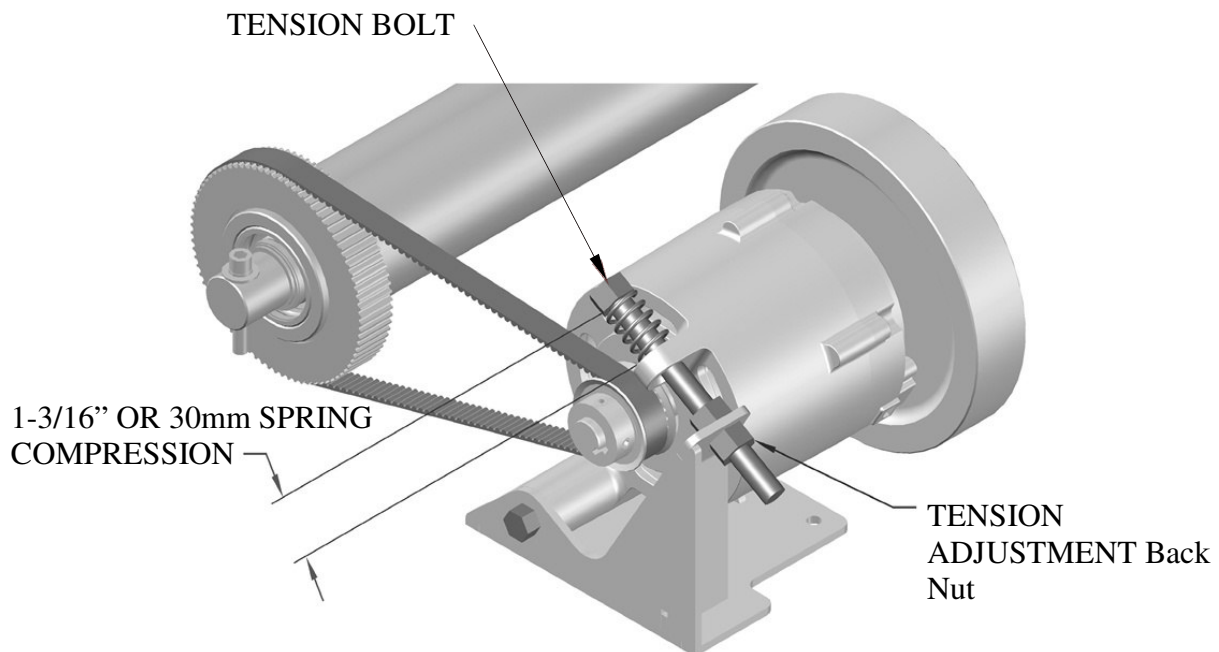

Exterior Care

The powder-coat finish on your TRACKMASTER® is an extremely durable finish and requires minimal care. Do not allow perspiration to build up on your treadmill. Wipe the unit daily.

Elevation Screw Lubrication

The Elevation Screw must be cleaned and lubricated every 6 months to maintain proper operation of the treadmill. Failure to perform this maintenance function will result in premature wear and ultimate failure of the lift mechanism.

This procedure requires the following tools:

- TRACKMASTER® grease (Part # 317-160-165)
 - Clean, lint-free cloth
 - Small paint brush
1. Raise the TRACKMASTER® to its maximum elevation.
 2. Turn the main power switch to the OFF position, and unplug the treadmill from its outlet.
 3. Using a lint-free cloth, remove the old lubricant and accumulated dust from the elevation screw.
 4. Use a small brush to reapply a thin coat of grease to the threads of the elevation screw. Do not use too much grease—the excess could squeeze onto the floor and create a slip-and-fall hazard.
 5. Return the unit to service.

Running Deck Maintenance

The TRACKMASTER® running deck is maintenance-free and offers (2) running deck surfaces for double the life of ordinary treadmills.

NOTE: Do not use silicone sprays to wax your treadmill deck. Using silicone sprays may void the warranty. Such sprays can bring about surface changes that may result in hesitation or excessive belt slip.

If running deck surface becomes grooved due to wear, it can be renewed by flipping the deck to the opposite side.

8

Parts List with Part Numbers

Motor Mount Assembly

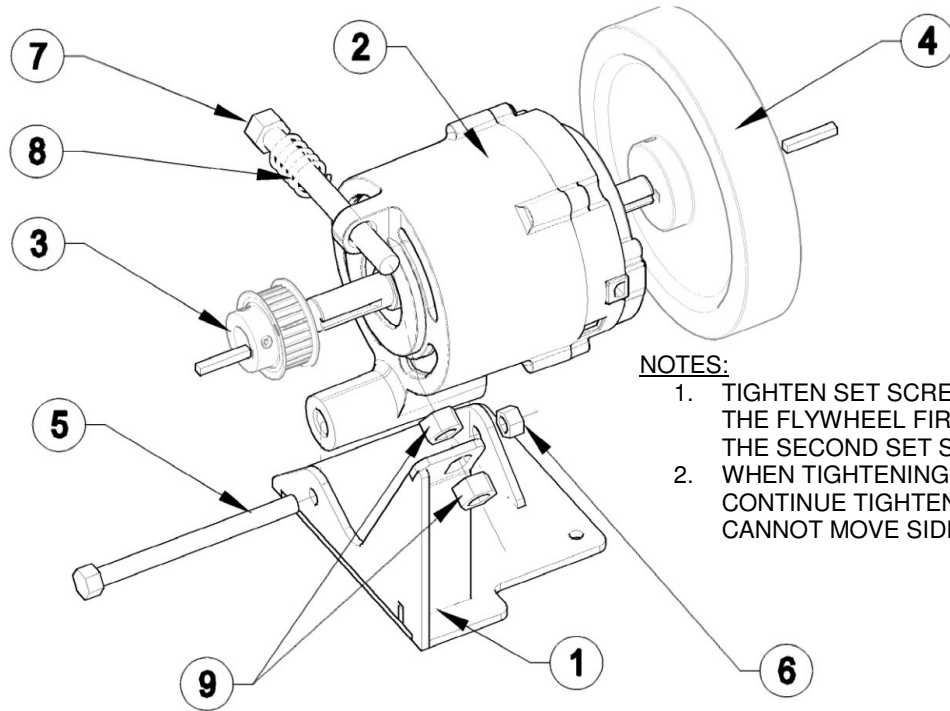

- NOTES:**
1. TIGHTEN SET SCREWS ON KEY WAY OF THE FLYWHEEL FIRST THEN TIGHTEN THE SECOND SET SCREW.
 2. WHEN TIGHTENING ITEM 5 & 6 CONTINUE TIGHTENING UNTIL MOTOR CANNOT MOVE SIDE TO SIDE.

Item	Description	Part Number	Qty
1	DC Motor Base	317-701-001	1
2	Motor DC Servo PMCFA-00101-03	317-160-197	1
3	Sprocket Drive 530-5MGT-15	317-160-201	1
4	Flywheel DC W/Magnet .50 dia	317-160-200	1
5	HHCS 7/16-14 x 5" Lg	001-2332	1
6	NLN 7/16-14	001-2333	1
7	HHCS 1/2-13 5" Lg All Thread	001-2331	1
8	Spring Motor Tension	317-160-218	1
9	HN 1/2-13 Gr5	001-1390	2

Circuit Board Assembly

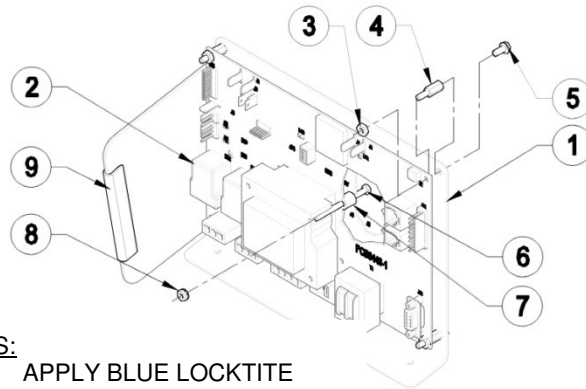

NOTES:
 APPLY BLUE LOCKTITE
 THREADLOCKER TO ITEM 8

Item	Description	Part Number	Qty
1	Bracket Circuit Board	317-709-001	1
2	Board FG0495-0 Universal Power Supply	317-160-199	1
3	HN #8-32 Nylon	001-1763	4
4	Mount Inverter Isolation	317-160-040	4
5	HHWHTS #8-32 x .375	001-1744	4
6	RHMS #6-32 x 2.5" Lg	001-1890	1
7	Standoff Round .50 Lg .166 ID	001-1854	1
8	K-Lock Nut #6-32	001-1858	1
9	Trim Black 3" Lg	001-102-044	1

Elevation Assembly

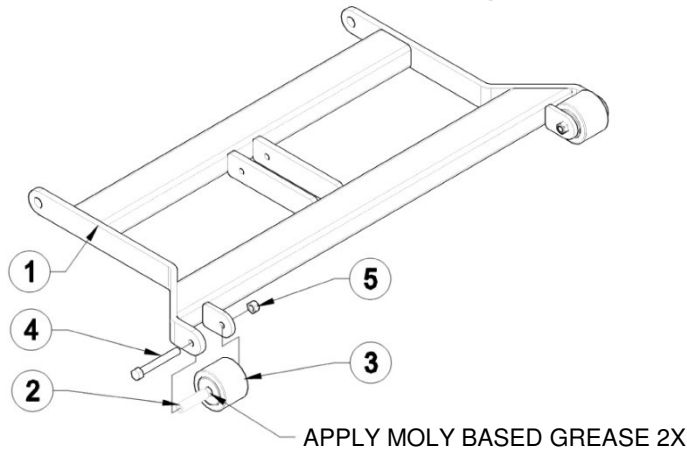

Item	Description	Part Number	Qty
1	Elevation Weldment TMX428	317-702-002	1
2	Spanner Wheel	317-160-054	2
3	Wheel Landing Gear	317-160-005	2
4	HHCS 3/8-16 x 3.25 Lg Gr5	001-1519	2
5	NLN 3/8-16	001-1430	2

Pull Tether Assembly

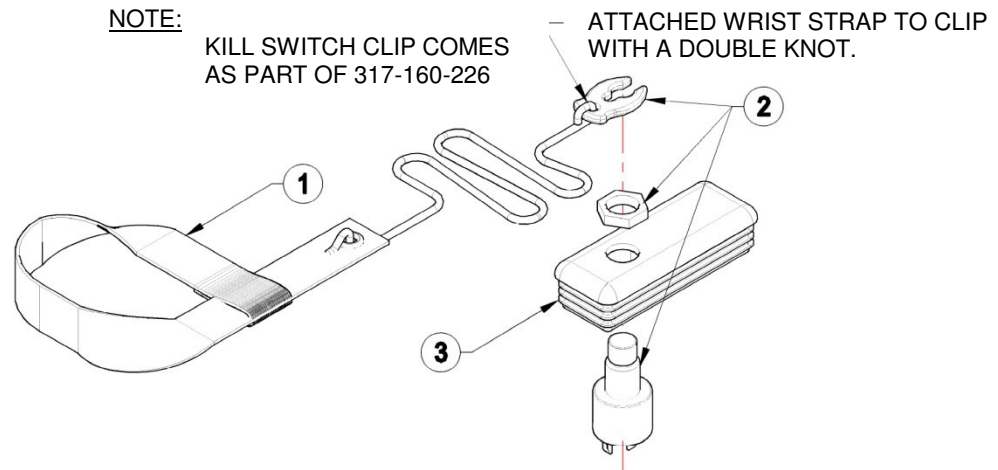

Item	Description	Part Number	Qty
1	Tether Pull w/Wrist strap	317-160-229	1
2	E-Stop Kill Switch LS500	317-160-226	1
3	Cap 1.50 x 4.00 LPDE BLK Modified	317-160-230	1

Emergency Stop Assembly's

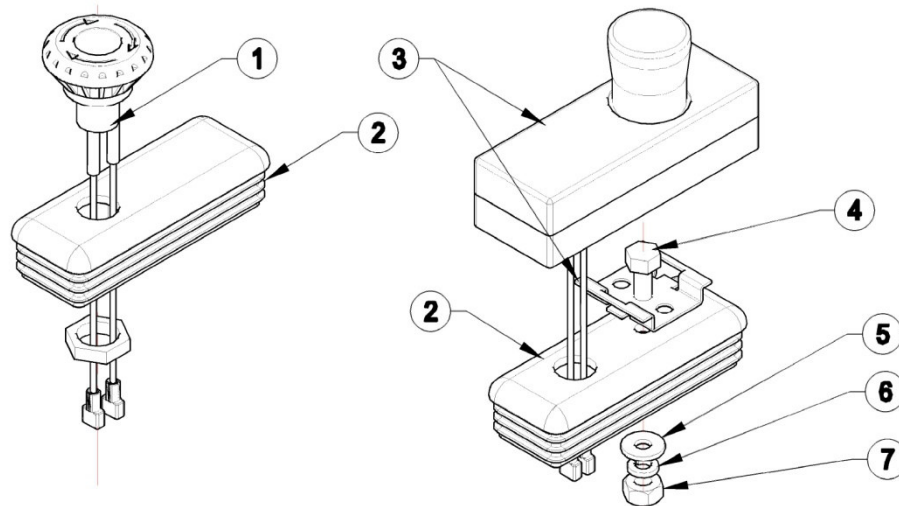

Item	Description	Part Number	Qty
1	Emergency Stop IDEC	317-160-268	1
2	Cap 1.50 x 4.00 LPDE BLK Modified	317-160-226	1
3	Emergency Stop RAFI (Alternative E-Stop)	317-160-230	1
4	Bolt HHCS 1/4-20 x 3/4" Lg Gr 5	001-1186	1
5	Flat Washer 1/4"	001-1439	1
6	Lock Washer 1/4"	001-1450	1
7	Nut HN 1/4-20 Gr 5	001-1386	1

Motor Pan Assembly

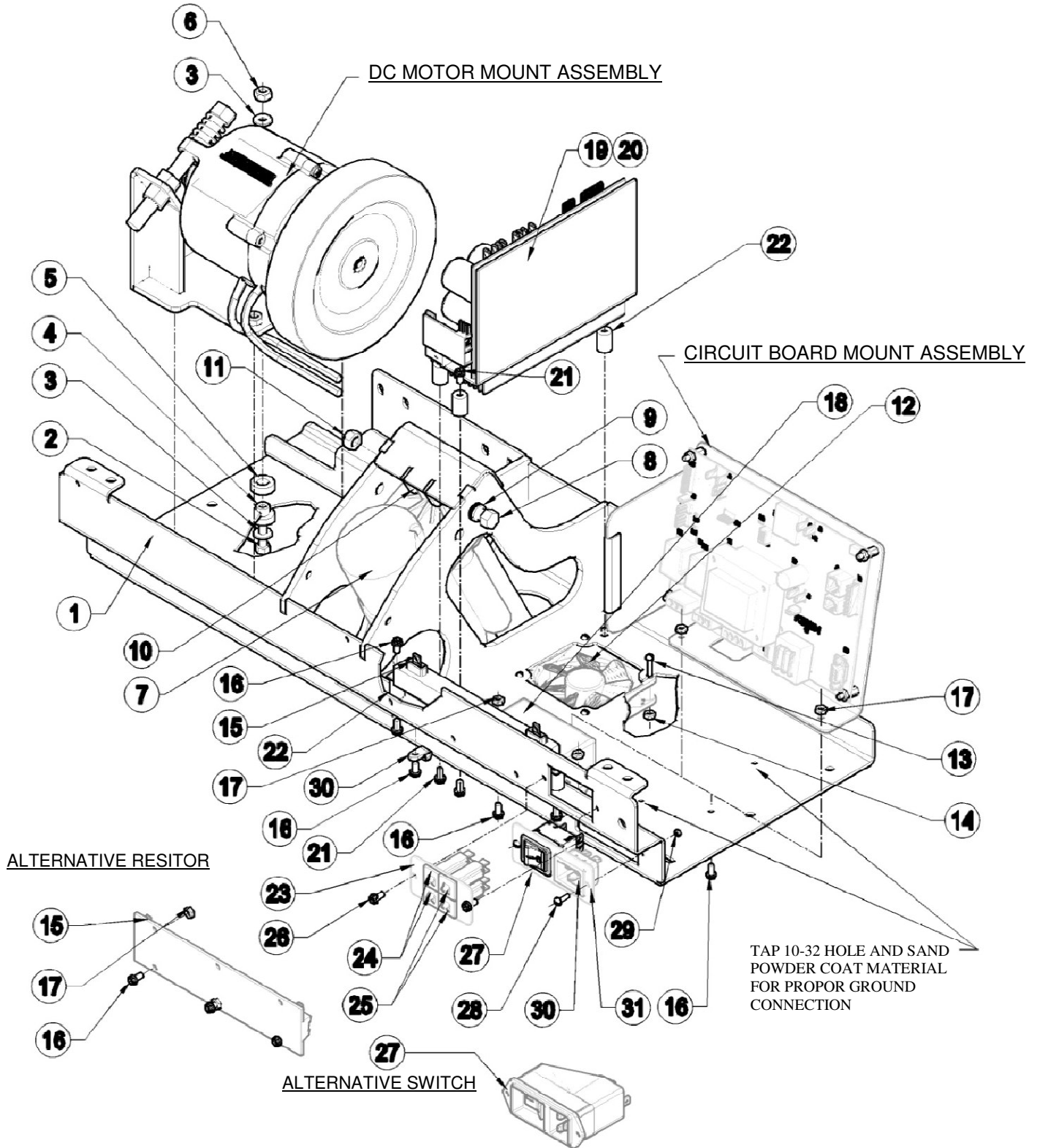

Motor Pan Assembly

Item	Description	Part Number	Qty
1	Motor Pan Weldment	317-700-001	1
2	HHCS 1/4-20 x 1.25 Lg Gr 2	001-1159	4
3	FW 1/4" Dia	001-1439	8
4	Motor Isolation Stem	317-160-216	4
5	Motor Isolation Spacer	317-160-217	4
6	NLN 1/4-20	001-1427	4
7	Actuator 115V Actuator 220V	317-160-090 317-160-029	1
8	HHCS 3/8-16 c 5.0" Lg Gr 5	001-1743	1
9	FW 3/8" Dia	001-1441	3
10	Washer Nylon	317-160-086	3
11	NLN 3/8-16	001-1430	1
12	Fan Assembly DC W/Connector	317-160-202	1
13	RHMS #6-32 x .50" Lg	001-1851	4
14	K-Lock Nut #6-32	001-1858	4
15	Resistor Omite 85/150MJ40R0DE Alternative Resistor Omite	317-160-233	1
16	HNS #8-32 Flange	001-1636	7
17	HHWHTS #8-32 X .50" Lg	001-1764	7
18	Filter CorCom F4635	317-160-240	1
19	Drive DC Servo PC2303-012-N	317-160-196	1
20	Regen Module RA2302		
21	RHMS #10-32 X .375 LG	001-1755	6
22	NYLON ISOLATOR #10-32	317-160-259	5
23	Plate Breaker Trackmaster	317-710-001	1
24	Breaker 3 amp	317-160-220	2
25	Breaker 1/4 amp	317-160-024	2
26	HHWHTS #8-32 x .375" Lg	001-1744	2
27	Switch TA35-C324-L200C0 Alternative Switch "Schurter Power Entry Module"	317-160-256 317-160-139	1
28	RHMS #6-32 x .50" Lg	001-1851	2
29	K-Lock Nut #6-32	001-1858	2
30	POWER CORD INLET C-20 4793.4000	317-160-257	1
31	PLATE SWITCH TMX428	317-718-001	1

Motor Pan Assembly Wiring

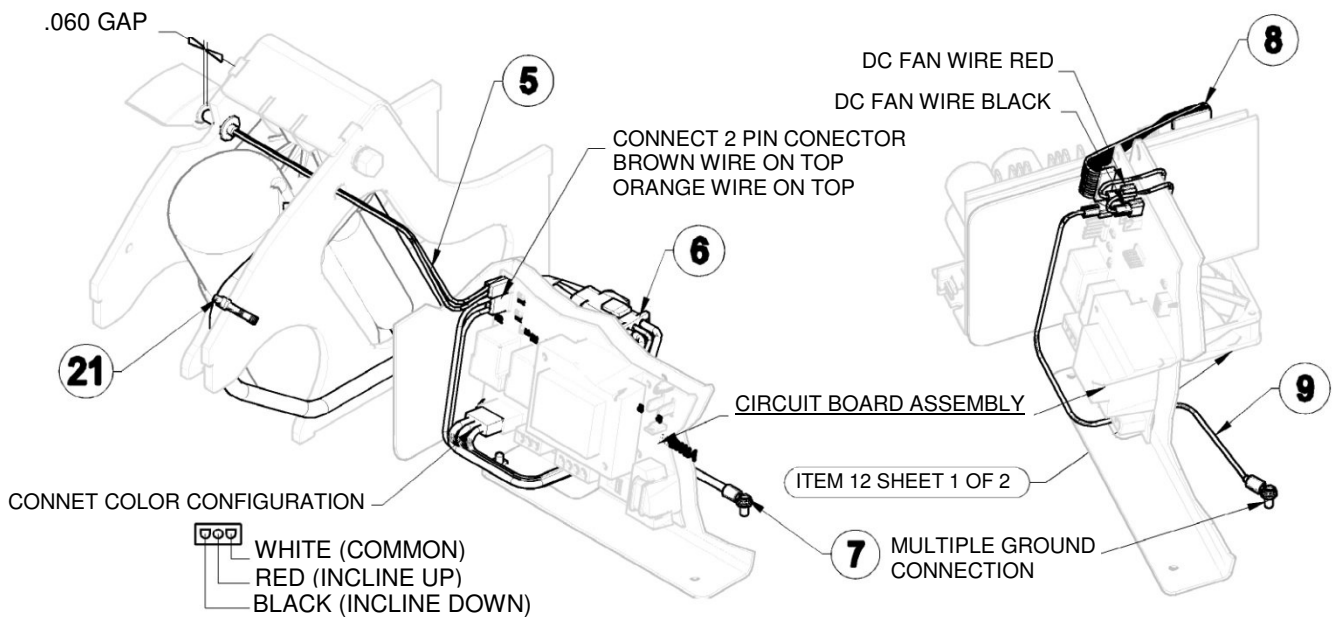
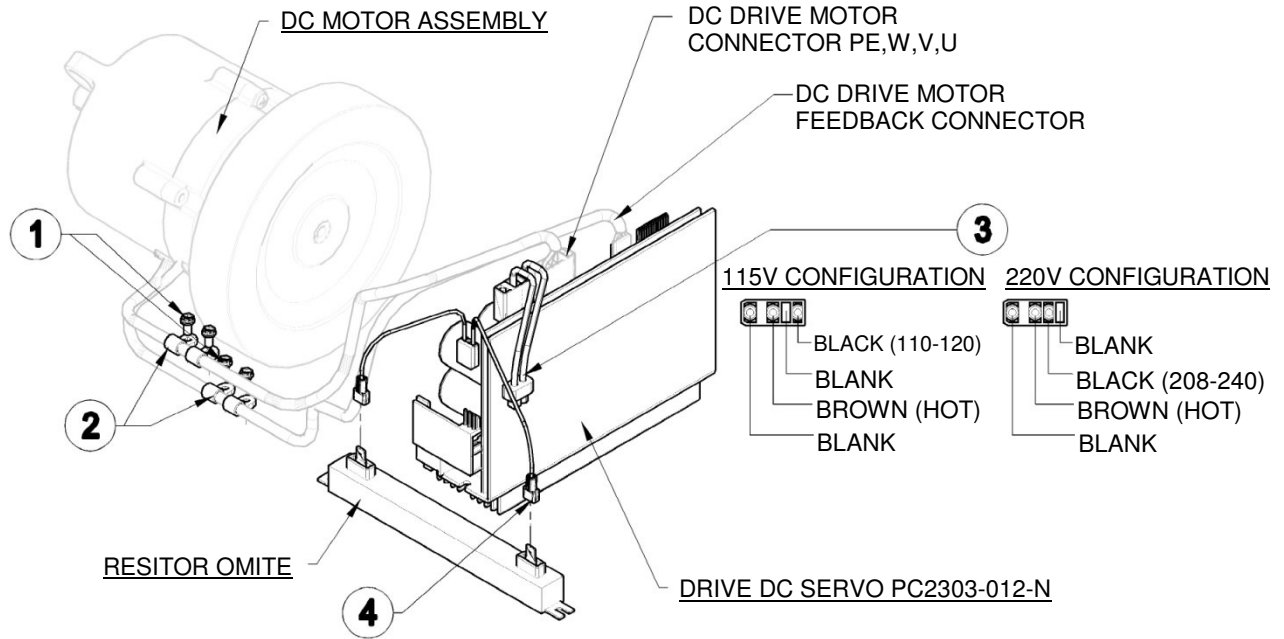

Motor Pan Assembly Wiring

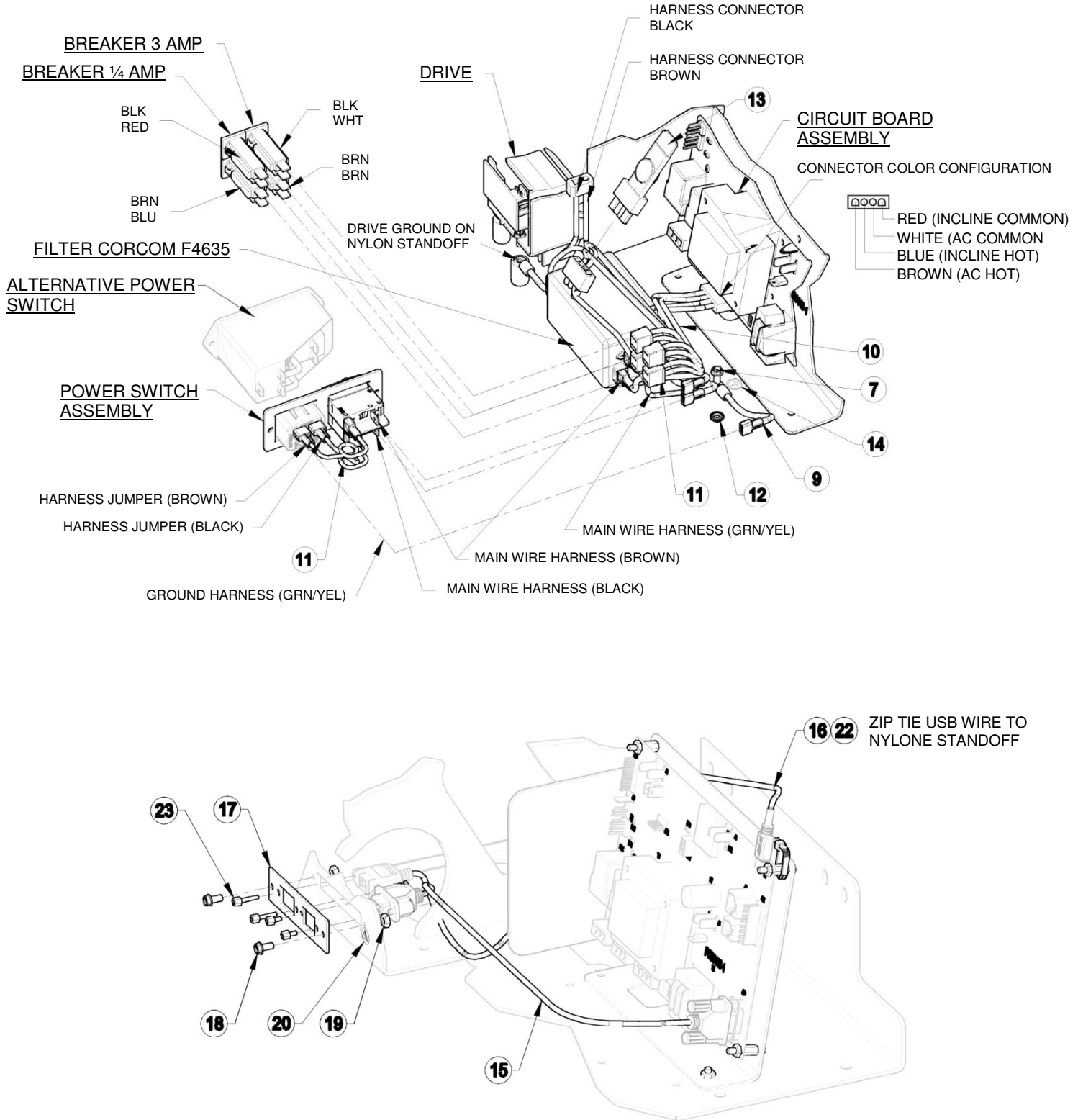

Motor Pan Assembly Wiring

Item	Description	Part Number	Qty
1	Screw HHWTS #8-32 x .375 Lg	001-1744	4
2	Clamp Plastic 1/4" ID	317-160-227	4
3	Harness 110V DC Treadmill Harness 220V DC Treadmill	317-160-261 317-160-262	1
4	Harness Resistor	417-160-026	1
5	Speed Sensor	317-160-034	1
6	Harness Elevation	317-160-231	1
7	HH Screw #10-32 x .375 Lg GRD	317-160-076	2
8	Harness Motor Controller	417-160-031	1
9	Harness Ground	317-160-070	2
10	Harness Main DC Treadmill	317-160-247	1
11	Harness Jumper	317-160-071	2
12	LW #10 EXT Tooth	001-1751	1
13	Surge Suppressor	317-160-129	1
14	Decal ground	317-160-273	1
15	Cable RS232 Panel Mount	317-160-236	1
16	Cable USB Panel to USB B	317-160-237	1
17	Plate RS232 & USB	317-160-254	1
18	HHCS #8-32 x .50 Lg	001-1764	2
19	HNS #8-32 Flange Nut	001-1636	2
20	Decal Caution	317-160-274	2
21	Zip Tie 8" Lg	317-160-280	1
22	Zip Tie 4" Lg	317-160-075	1
23	RMHS #4-40 x .375 Lg	001-2360	2

Frame Assembly

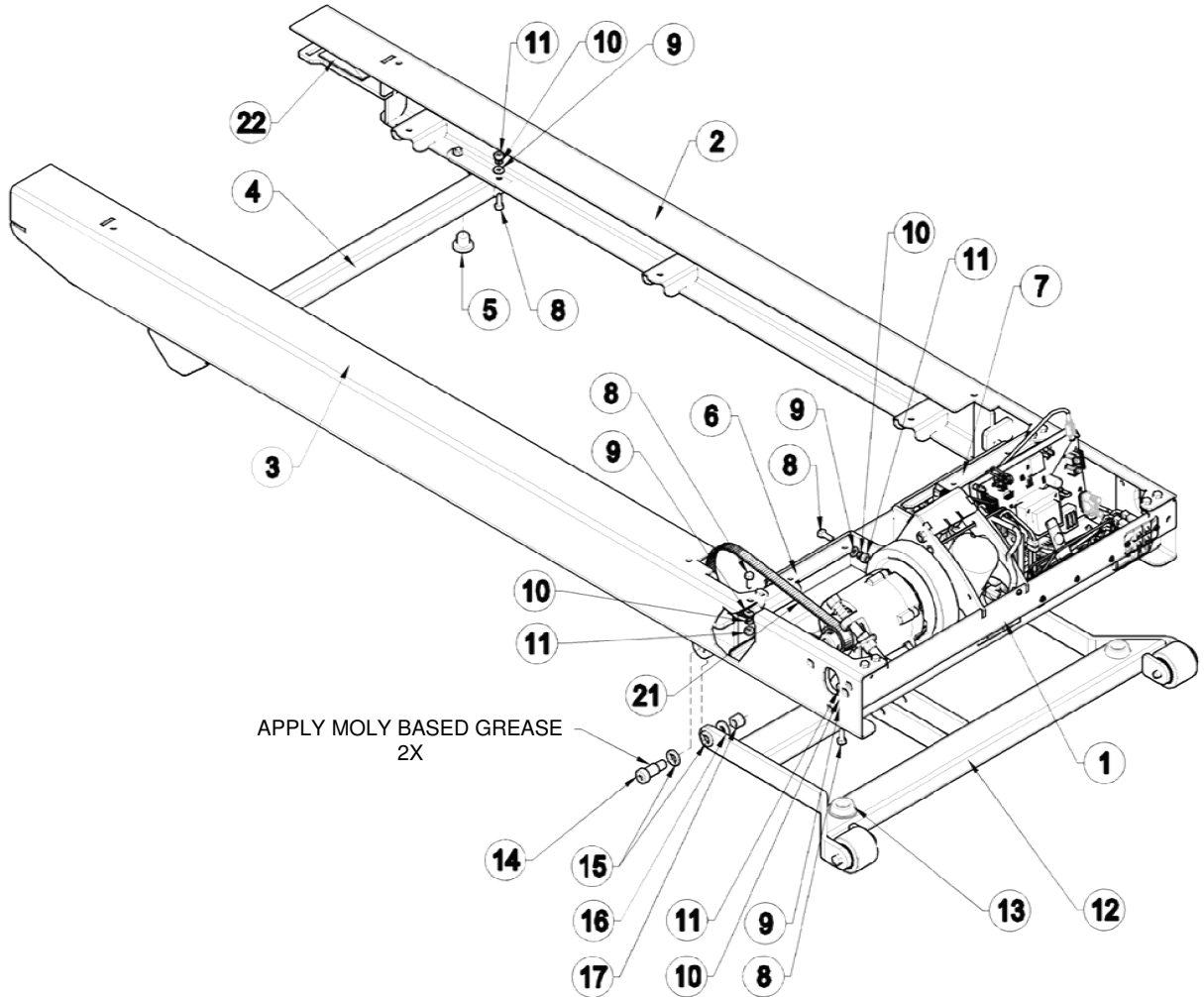

Frame Assembly

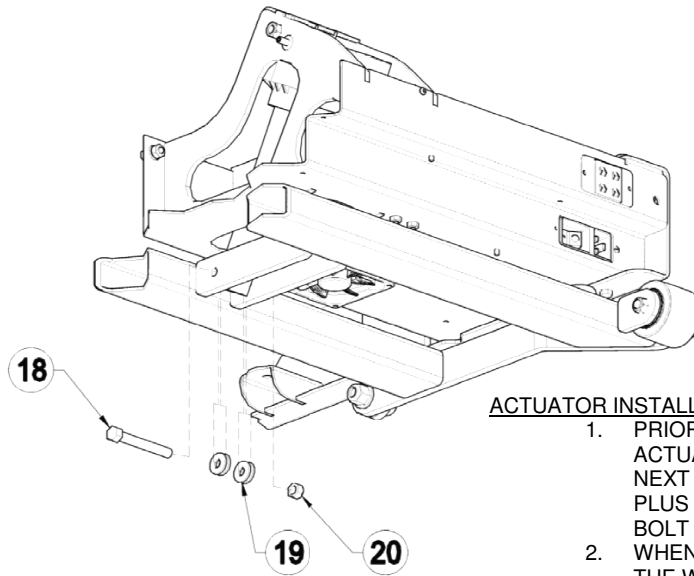

ACTUATOR INSTALLATION NOTES:

1. PRIOR TO INSTALLATION OF BOLT, TURN ACTUATOR END CLOCKWISE UNTIL IT STOPS. NEXT TURN COUNTER CLOCKWISE 1 ½ TURN OUT PLUS ANY ADDITIONAL REVOLUTION TO ALLOW BOLT ALIGNMENT.
2. WHEN TIGHTENING ELEVATION BOLT AND NUT THE WASHERS MUST MOVE FREELY.

Item	Description	Part Number	Qty
1	Motor Pan Assembly TMX428	317-Various	1
2	Side Channel LH Weldment	317-704-001	1
3	Side Channel RH Weldment	317-705-001	1
4	Rear Foot	317-706-001	1
5	Stem Bumper	317-160-141	2
6	Bracket Motor Pan Right	317-708-001	1
7	Bracket Motor Pan Left	317-707-001	1
8	Bolt HHCS ¼-20 x .75" Lg Gr 5	001-1186	26
9	Flat Washer ¼" Dia	001-1439	26
10	Lock Washer ¼" Dia	001-1450	26
11	Nut HN ¼-20 Grade 5	001-1386	26
12	Landing Gear Assembly	317-702-001	1
13	Bumper 1.8" Dia Black	317-160-106	2
14	Shoulder Bolt HSHSS 5/8" Dia x 1" Lg	001-1730	2
15	Elevation Delrin Spacer	317-160-060	4
16	Flat Washer ½" Dia	001-1443	2
17	Nylon Lock Nut NLN ½"-13	001-1676	2
18	Bolt HHCS 3/8-16 x 3" Lg Grade 5	001-1699	1
19	Washer Nylon	317-160-086	4
20	Nylon Lock Nut 3/8-16	001-1430	1
21	Belt Drive	317-160-026	1
22	Anti Slip Safety Walk "Cut 1.5" x 4"	317-160-084	2

Deck Assembly

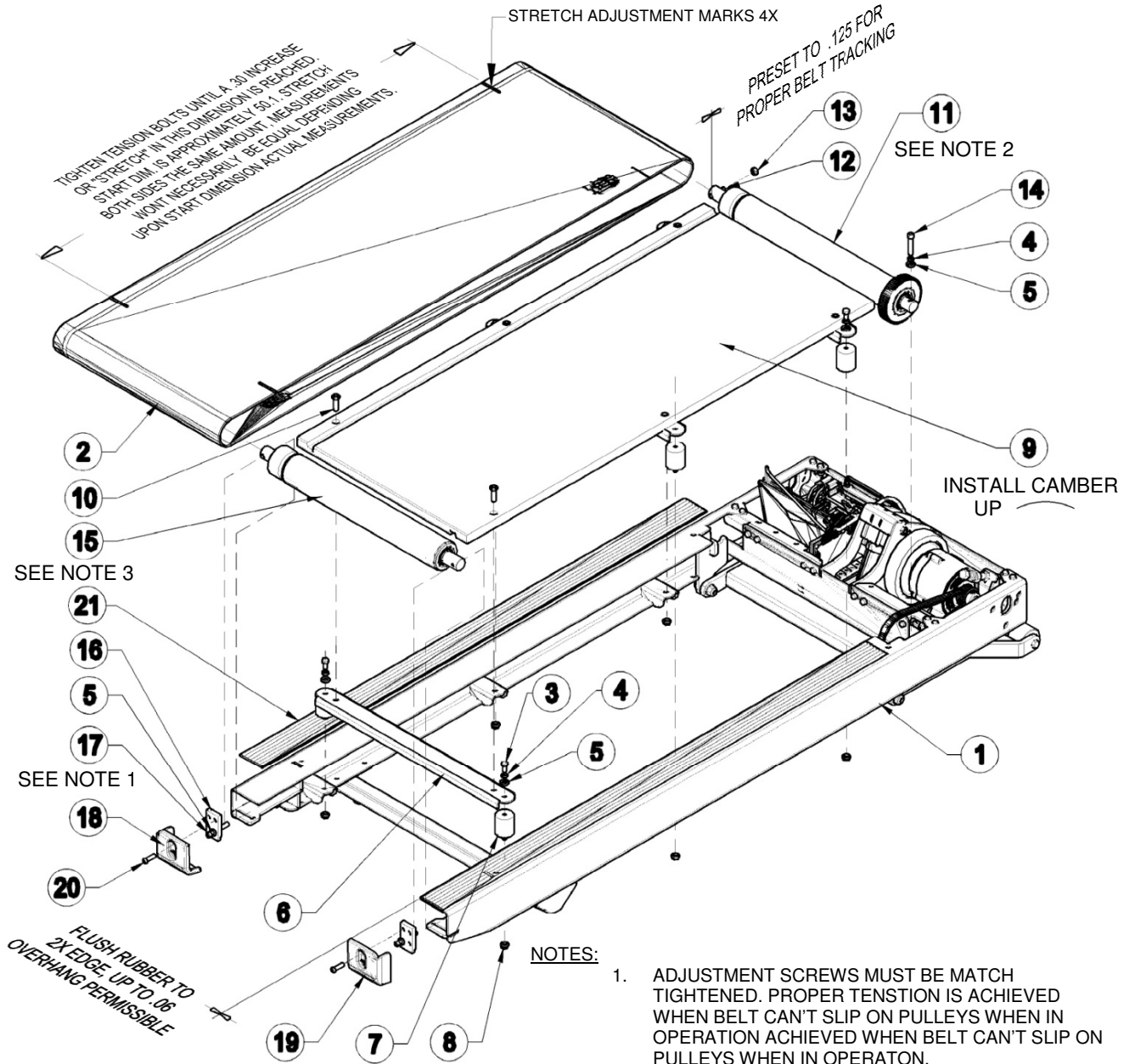

Deck Assembly

Item	Description	Part Number	Qty
1	Frame Assembly TMX428	317-Various	1
2	Belt Running with V-Guide	317-160-002	1
3	Bolt HHCS 5/16-18 x .75" Lg	001-1167	6
4	Lock Washer 5/16" Dia	001-1451	7
5	Flat Washer 5/16" Dia	001-1440	9
6	Deck Support Channel Weldment	317-379-001	3
7	Deck Isolator 1.75" Dia with Stud	317-345-003	6
8	Flange Lock Nut HNS 5/16-18	001-1398	6
9	Deck Running Board	317-160-025	1
10	Screw HSFCHCS 5/16"-18 x 1.5" Lg PLTD	001-1739	6
11	Roller Front	317-160-156	1
12	Set Screw 5/16"-18 x 1.75" Lg	317-160-224	1
13	Nut FHNZ 5/16-18 Grade 5	001-1387	1
14	Bolt HSHCS 5/16"-18 x 2" Lg PLTD	001-1748	1
15	Rear Roller	317-160-157	1
16	Belt Tension Plate	317-649-001	2
17	Screw HSHCS 5/16"-18 x 3" Lg PLTD	001-1737	2
18	End Cap LH	317-160-175	1
19	End Cap RH	317-160-176	1
20	Screw HSBHCS 5/16"-18 x 1" Lg PLTD	001-1735	2
21	Extrusion Anti Skid Rubber 60" LG	317-160-055	2

Final Assembly

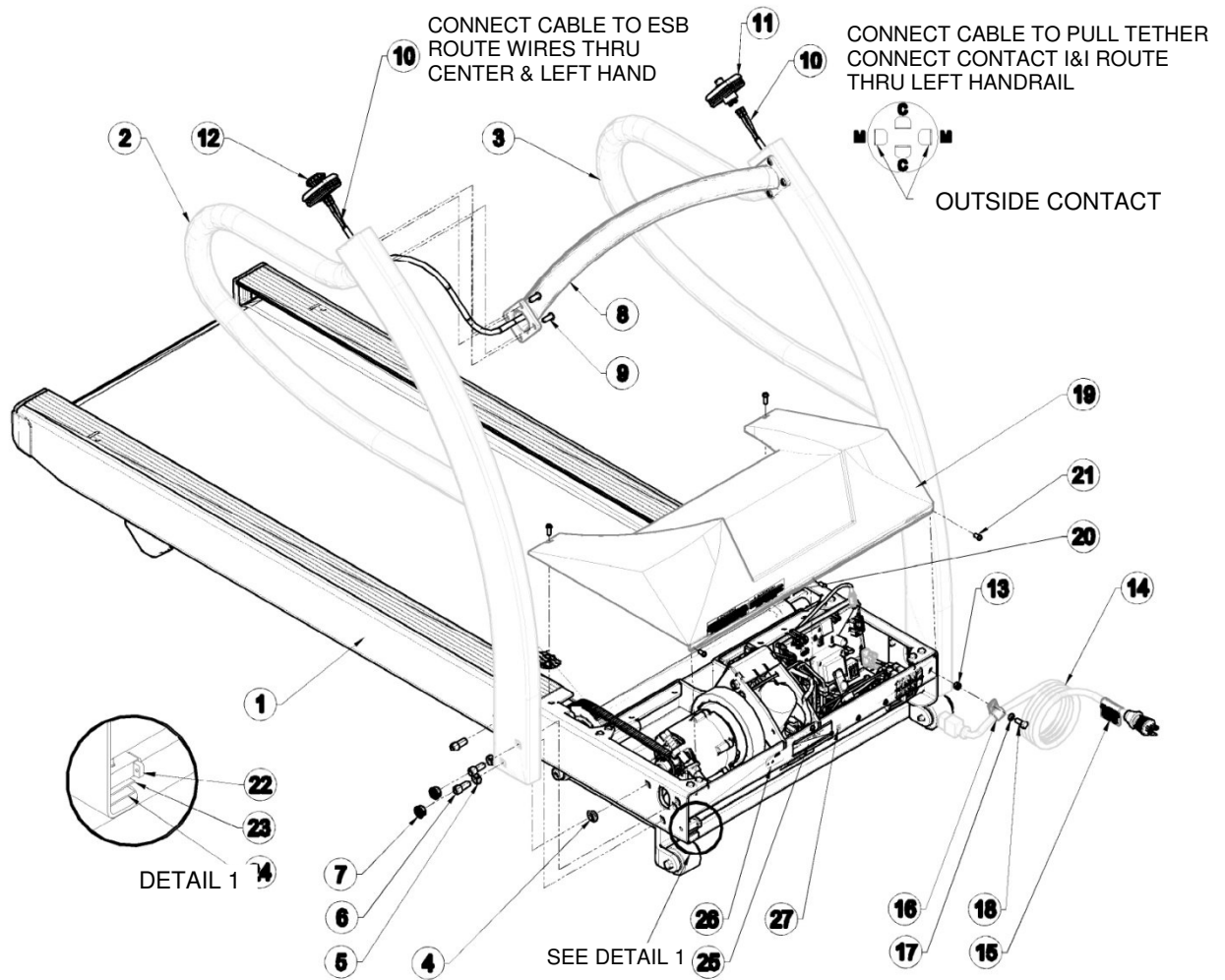

Final Assembly Circuit Board Connection

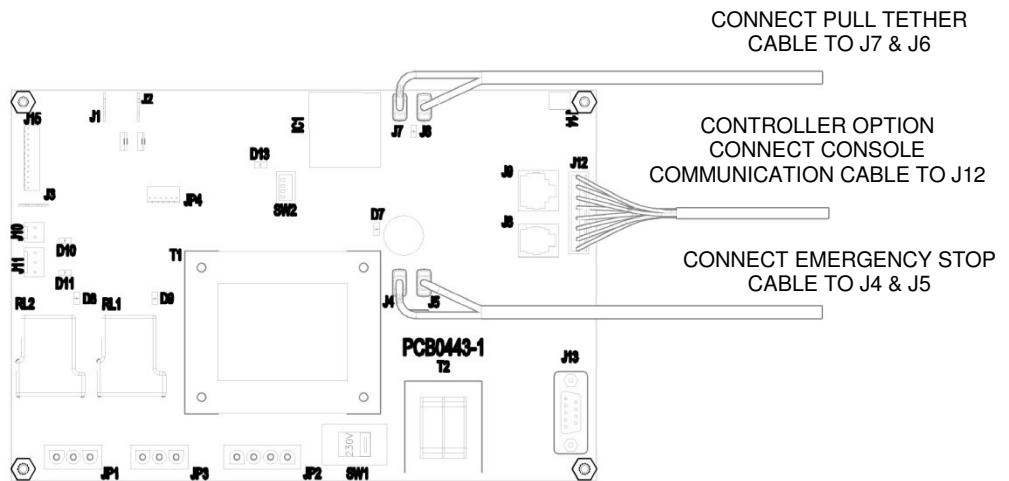

Final Assembly

Item	Description	Part Number	Qty
1	Running Deck Assembly TMX428	317-Various	1
2	Handrail RH TMX428	317-712-001	1
3	Handrail LH TMX428	317-713-001	1
4	Washer Nylon	317-160-086	2
5	Lock Washer 3/8"	001-1452	4
6	Screw HSHCS 3/8"-16 x 1" Lg PLTD	001-1859	6
7	Dome Plug	317-180-008	4
8	Handrail Center TMX428	317-711-001	1
9	Screw HSBHCS 1/4"-20 x 3/4" Lg	001-2351	8
10	Harness ESB & Pull Tether	317-160-263	2
11	Pull Tether Assembly	317-720-001	1
12	Emergency Stop Assembly RAFI	317-721-001	1
	Emergency Stop Assembly IDEC	317-722-001	
13	Riv-Nut 1/4"-20	001-1686	1
14	Power Cord 110-120 VAC C-19 NEMA 5-15	317-160-228	1
	Power Cord 220-240 VAC C-19 NEMA 6-15	317-160-242	
	Power Cord 200-240 VAC C-19 CEE 7/7 EURO	317-160-189	
	Power Cord 230 VAC C-19 UK BS1363	317-160-188	
15	Decal Hi-Pot Power Cord	317-160-258	1
16	Clamp Support	317-160-092	1
17	Lock Washer 1/4"	001-1450	1
18	Bolt HHCS 1/4"-20 x 3/4" Lg Gr 5	001-2351	1
19	Hood TMX428	317-160-235	1
20	Decal Caution	317-160-018	1
21	Screw HHWHTS #8-32 x 3/8" Lg	001-1744	5
22	Test Plug	317-187-003	1
23	Velcro Hook Backing 1" lg.	317-160-056	1"
24	Velcro Backing 1" Lg.	317-160-057	1"
25	Decal Serial	317-Various	1
26	Decal ETL	317-160-130	1
27	Decal Wheelie Bin	317-160-164	1

TMX428CP Controller Assembly

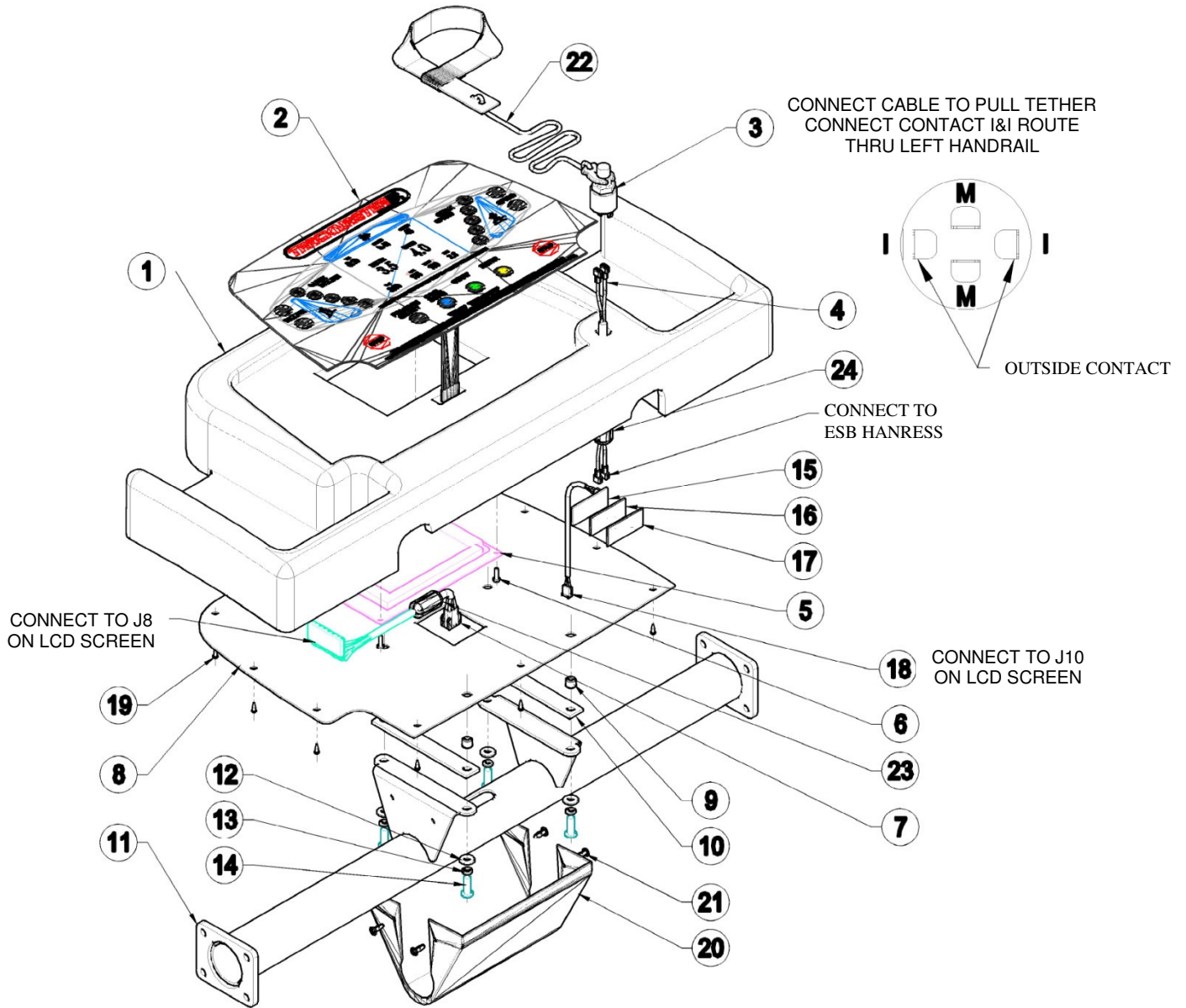

TMX428CP Controller Assembly

Item	Description	Part Number	Qty
1	Console Plastic LCD Configuration	317-160-270	1
2	Membrane TMX428 Overlay	317-160-232	1
3	E-Stop Kill Switch LS500	317-160-226	1
4	Harness Jumper Pull Tether	317-160-266	1
5	Board FG0960-0 Console	417-160-017	1
6	RHMS #6-32 3/8" Lg	001-1745	4
7	Harness Communication Jumper	317-160-265	1
8	Back Plate Fitness Panel	317-731-001	1
9	Fastener 1/4-20 UNC Riv-Nut	001-1686	4
10	Rubber Control Dampener	317-160-277	2
11	Handrail Controller TMX428CP	317-719-001	1
12	Flat Washer 1/4" Dia	001-1439	4
13	Lock Washer 1/4" Dia	001-1450	4
14	Screw BHSCS 1/4"-20 x 3/4" SS	001-1796	4
15	Polar Board FG0315	317-160-168	1
16	Velcro Hook 5/8" x 2" Lg	317-160-056	1
17	Velcro Loop 5/8" x 2" Lg	317-160-057	1
18	Polar Cable 3 pin 12" CA0045	317-160-169	1
19	K-Lock Nut #6-32	001-1823	10
20	Cover Plastic Controller	317-160-234	1
21	Screw HSBHCS 10-32 x 1/2" Lg	001-2334	4
22	Tether Pull W/Wrist Strap	317-160-229	1
23	Fair-Rite Ring 0446164951	317-160-290	1
24	Fair-Rite Ring 0461164281	317-160-291	1



Full Vision Inc.
3017 Full Vision Drive
Newton, KS. 67114
www.full-vision.com

