

ergoselect 100/150/200

Bicycle Ergometer

Operator's Manual

201000134000 • Version 2020-01-14/Rev 04 • English



This manual was written with the utmost care. Should you still find details that do not correspond with the system, please let us know and we will correct the issue as soon as possible.

We reserve the right to modify the design and technical features of the device and are not bound by the information and illustrations provided in this manual.

All trademarks appearing in this document are trademarks of their respective owners. Their protection is acknowledged.

No part of this manual may be reprinted, translated or reproduced without the manufacturer's written permission.

This manual is not subject to any change order service. Please contact the manufacturer for the latest document revision.

ergoline GmbH
Lindenstraße 5
72475 Bitz
Germany

Tel.: +49-(0) 7431 98 94 - 0
Fax: +49-(0) 7431 98 94 - 128
e-mail: info@ergoline.com
http: www.ergoline.com

Printed in Germany

CE 0123

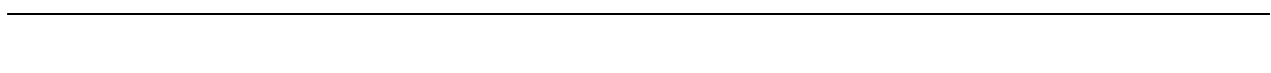

CONTENTS

General Information	5
Safety Information	6
Intended Use	8
Symbols.	9
Setup and Mains Connection.	10
Controls and Indicators.	10
Transport	11
Setup	11
Mounting the Control Terminal (P or K)	12
Connecting the Power Cord.	12
Connecting the ECG Cable	14
Connecting the Blood Pressure Cuff	15
Preparing the Patient	16
Adjusting the Saddle and the Handlebar.	16
Preparing the Patient for Blood Pressure Measurements	17
Checking the Cuff Tubing	18
Operation	19
Control terminal P.	19
Turning the System On	19
Operating Modes with Control Terminal P	20
PC Mode.	21
Ergometry.	22
Manual	24
Settings with Control Terminal P.	25
Control Terminal K.	30
Turning the System On	30
Operating Modes with Control Terminal K	31
Speed readout.	31
PC Mode.	32
Ergometry.	33
Manual	35
Training	36
Training with Chip Card.	37
Settings for Control Terminals K	39
Cleaning, Maintenance, Disposal	46
Technical Specifications	49
Electromagnetic Compatibility EN 60601-1-2.	53

GENERAL INFORMATION

- The product ergoselect bears the CE marking CE-0123 (Notified Body: TÜV), indicating its compliance with the provisions of the Council Directive 93/42/EEC about medical devices and fulfills the essential requirements of Annex I of this directive.
The CE marking covers only the accessories listed in the Order Information chapter.
The ergometer is an MDD class IIa product.

- The device fulfills the requirements of standard EN 60601-1 "Medical Electrical Equipment, Part 1: General Requirements for Safety" as well as the interference protection requirements of standard EN 60601-1-2 "Electromagnetic Compatibility – Medical Electrical Devices".
The radio-interference emitted by this product is within the limits specified in EN 55011, class B.

- The symbol  means: protection class II

- This manual is an integral part of the equipment. It should be available to the equipment operator at all times. Close observance of the information given in the manual is a prerequisite for proper device performance and correct operation and ensures patient and operator safety. Please note that information pertinent to several chapters is given only once. Therefore, read the manual once carefully in its entirety.

- The symbols   mean:

Consult accompanying documents.

They indicate points which are of particular importance in the operation of the device.

- Observance of the safety information protects from injuries and prevents inappropriate use of the device. All equipment users and persons responsible for assembly, maintenance, inspection and repair of the device must read and understand the content of this manual, before using or work on it.
Paragraphs with special symbols are of particular importance.

- If unauthorized individuals open the control terminal, damaging the calibration sticker, any warranty claim shall become void.

- This manual reflects the equipment specifications and applicable safety standards valid at the time of printing. All rights are reserved for devices, circuits, techniques, software programs, and names appearing in this manual.

- On request ERGOLINE will provide a Service Manual.

- The ERGOLINE quality management system complies with the standard EN ISO 13485: 2016.
- The safety information given in this manual is classified as follows:

Danger

indicates an imminent hazard. If not avoided, the hazard will result in death or serious injury.

Warning

indicates a hazard. If not avoided, the hazard may result in minor injury and/or product/property damage.

Caution

indicates a potential hazard. If not avoided, the hazard may result in minor injury and/or product/property damage.

- To ensure patient safety, the specified measuring accuracy, and interference-free operation, we recommend using only original ERGOLINE accessories. The user is responsible if non-ERGOLINE accessories are used.
- ERGOLINE is responsible for the safety, reliability, and performance of the equipment, only if
 - modifications and repair are carried out by ergoline GmbH or by an organization expressly authorized by ergoline GmbH
 - the equipment is used in accordance with the instructions given in this operator's manual.

ergoline GmbH
Lindenstrasse 5
72475 Bitz
Germany

Phone: +49-(0)-7431 - 9894-0
Fax: +49-(0)-7431 - 9894-128
e-mail: info@ergoline.com
http: www.ergoline.com

SAFETY INFORMATION

Danger

- Explosion Hazard •

The device is not designed for use in areas where an explosion hazard may occur.

Explosion hazards may result from the use of flammable anaesthetics, skin cleansing agents or disinfectants.

Warning

- Patient Hazard, Equipment Damage •

Do not expose the ergoselect to direct sunlight to prevent system components from reaching inadmissible high temperatures.

Do NOT use the ergoselect outdoors (medical device). Furthermore the device has no additional protection against the ingress of humidity. Humidity inside the device may cause equipment malfunctions and increases the risk of an electric shock.

Additionally, the device should not be operated in the vicinity of electric power plants, because they may impair equipment functions.

The ergoselect ergometer may only be used in combination with accessories approved by ergoline GmbH.

- Risk to Persons •

Before using the ergometer, the operator must ascertain that it is in correct working order and operating condition. The cables and connectors, in particular, must be checked for signs of damage. Damaged parts must be replaced immediately, before use.

- Equipment Malfunction •

Only the special shielded cables supplied by ERGOLINE may be used to connect the device to other pieces of equipment.

- Equipment Malfunction •

Cellular telephones may not be used in the immediate vicinity of the ergometer, because they might interfere with the proper functioning of the ergometer.

Electromagnetic interference most probably exists when the watt reading is unstable. If the displayed value changes frequently even though the speed is above 30 RPM, this may be due to electromagnetic interference.

Warning

- Shock Hazard •

When the ergometer is connected to other equipment or if a medical system is created, it must be ensured that the added leakage currents do not present a hazard.

In case of questions, please contact your ERGOLINE dealer or the ergoline GmbH Service Department.

For use, the ergometer must always be connected to electric installations that fulfill the local requirements.

- Patient Hazard •

The German Medical Device Operator Ordinance (MPBetreibV, § 5) demands that users

- *must be trained in the use of the ergometer*
- *must be familiar with the routines for handling and assembly of the ergometer*
- *must be familiar with and observe the safety rules and regulations for operation of this type of equipment*
- *must be informed about any other pertinent rules and regulations (e.g. safety features)*
- *must be informed about the potential hazards arising from the use of this type of equipment.*
- *make sure that no unauthorised changes are carried out.*

- Patient Hazard •

Only properly trained and appropriately qualified personnel is allowed to operate and work with the medical device.

Hint

Removing the power cord results in complete disconnection from mains (all poles).

Caution

Additional equipment connected to medical electrical equipment must comply with the respective IEC or ISO standards (e.g. IEC 60950 for data processing equipment). Furthermore all configurations shall comply with the requirements for medical electrical systems (see IEC 60601-1-1 or clause 16 of the 3Ed. of IEC 60601-1, respectively).

Anybody connecting additional equipment to medical electrical equipment config ures a medical system and is therefore responsible that the system complies with the requirements for medical electrical systems. Attention is drawn to the fact that local laws take priority over the above mentioned requirements. If in doubt, consult your local representative or the technical service department.

SAFETY INFORMATION FOR NON-INVASIVE BLOOD PRESSURE MEASUREMENT

Warning

- Patient Hazard •

Do not take blood pressure measurements with a cuff on patients suffering from sickle cell anemia or where skin lesions are likely to occur.

The cuff may cause hematomas in patients with severe blood coagulation disease. In these instances, the user must take a decision for or against automatic blood pressure measurements.

Caution

- Compromised Measuring Accuracy •

Arrhythmias occurring frequently during a measurement may compromise the accuracy of the measurement. In certain cases, a valid measurement will not be possible.

Electromagnetic fields are also capable of impairing the measuring accuracy.

Note

- *If the cuff pressure exceeds the maximum value of 300 mmHg during inflation, the inflation procedure will be aborted and the cuff deflated. As a redundant safety precaution, the cuff is immediately deflated when the cuff pressure exceeds 320 mmHg. You can check the proper functioning of this safety precaution by abruptly bending your arm while the cuff is being inflated, causing a brief overpressure in the cuff. The cuff must deflate immediately.*
- *Measurements that did not yield a valid measurement will not be repeated during the exercise test.*
- *If the inflation phase takes longer than 40 seconds or if an adequate pressure does not build up in the cuff within a reasonable period of time, the measurement will be aborted and the cuff deflated.*
- *If a valid measurement cannot be completed within 120 seconds, the measurement will be aborted and the cuff deflated.*
- *If the cuff pressure remains constant for some time, the measurement will also be aborted and the cuff deflated.*

CONTRAINDICATIONS

The following patient categories are excluded from using the device:

- patients feeling discomfort or suffering from dizziness, nausea or pain.
- patients under the influence of substances that may impair vigilance (alcohol, drugs, medication).

CONTRAINDICATIONS IN EXERCISE TESTING CARRIED OUT WITH ERGOMETERS

(source: Banerjee A et al., 2012)

Contraindications in exercise testing:

- acute myocardial infarction in the previous 4 to 6 days
- unstable angina with rest pain in the previous 48 hours
- uncontrolled heart failure
- acute myocarditis or pericarditis
- acute systemic infection
- deep vein thrombosis as it is likely to shift and cause pulmonary embolism
- uncontrolled hypertension with systolic blood pressure > 220 mmHg or diastolic blood pressure > 120 mmHg
- severe aortic stenosis
- severe hypertrophic obstructive cardiomyopathy
- untreated life-threatening arrhythmia
- dissecting aneurysm
- recent aortic surgery
- abnormalities during testing include:
 - abnormal ST-segment response (horizontal, planar or down-sloping depression of > 1 mm).
 - T-wave elevation of > 1 mm in leads without Q-waves.
 - T-wave changes such as inversion and pseudo-normalization when an inverted T-wave becomes upright are non-specific changes.

CRITERIA FOR STOPPING BICYCLE-BASED EXERCISE TESTING

(source: Banerjee A et al., 2012).

Criteria for stopping bicycle based exercise testing include:

ECG criteria

- severe ST depression of > 3 mm
- ST elevation > 1 mm in non-Q-wave lead
- frequent ventricular extra systoles
- onset of ventricular tachycardia
- new atrial fibrillation or supraventricular tachycardia
- development of new bundle branch block
- progression of heart block to second or third degree
- cardiac arrest

Clinical criteria

- excessive fatigue
- severe chest pain, dyspnea, or dizziness
- > 20 mmHg reduction in systolic blood pressure
- rise in blood pressure

INTENDED USE

The ergoselect is a computer-controlled medical ergometer. At pedal speeds between 30 and 130 RPM and loads between 6 and 999 watt, the ergometer operates independent of the pedal speed.

The speed-independent range is shown in the Appendix (Technical Specifications).

The ergoselect ergometer may only be used in exercise testing as well as for rehabilitation of cardiac and cardiovascular patients according to the instructions given in this manual. If the ergometer is used for other purposes, the manufacturer cannot be held liable for personal injuries or property damage resulting from the unintended use of the equipment.

Note – Applied Parts

- *Applied parts are components that are directly in contact with the human body (e.g., blood pressure measuring devices).*

Note – Stability

- *Ensure the stability of the ergometer. If the maximum permitted patient weight is exceeded by 10%, the stability of the ergometer can no longer be guaranteed. It may become unstable as a result.*

INTENDED USER

Only the intended users are allowed to use the ergometer.

The group of intended users includes

- healthcare professionals thoroughly instructed on the basis of the instructions for use
- patients of the intended patient group who have been thoroughly instructed by trained specialists

The group of intended users does not include persons with special needs, such as:

- impaired mental and physical abilities;
- impaired motor skills

which have an influence on the intended use of the medical device.

INTENDED PATIENT GROUP

The intended patient group includes all persons

- with a maximum weight of 160 kg.
- whose body height and age makes them eligible for exercise testing. Due to various ergonomic aspects, it is not possible to provide exact data for body height and age.
- whose medical condition has been checked by a medical specialist who judged them to be suitable for the application described in the intended use.

BIOCOMPATIBILITY

The parts of the product described in this manual, including all accessories that come in contact with the patient during the intended use, fulfill the biocompatibility requirements of the applicable standards if applied as intended.

If you have questions in this matter, please contact ERGOLINE or a representative.

APPLICABLE LAWS, REGULATIONS AND DIRECTIVES

- 93/42/EEC (Medical Device Directive of the EU)
- 89/336/EEC (Electromagnetic Compatibility Directive of the EU)
- EN 1060-1 Non-invasive sphygmomanometers, Part 1: General requirements
- EN 1060-3 Non-invasive sphygmomanometers, Part 3: Supplementary requirements for electro-mechanical blood pressure measuring systems

SYMBOLS

- 

Symbol 'type B applied part'.
Type B applied parts have no direct contact with patients and offer the lowest protection against electric shock.
- 

Symbol 'type BF applied part'.
Type BF applied parts are connected to the body of the patient and provide a higher degree of protection against electric shock. The applied parts are isolated.
- 

Caution, consult accompanying documents.
- 

Protection class II equipment.
- 

This symbol indicates that the waste of electrical and electronic equipment must not be disposed as unsorted municipal waste and must be collected separately.
Consult operating instructions.
- 

Catalog number.
- 

Serial number.
- 

Scheduled date of the next inspection (e.g., March 2020).
-

Toggle switch ON (voltage).
- 

Toggle switch OFF (voltage).
- 

CE mark per the Medical Device Directive 93/42/EEC of the European Union.
Notified body: TÜV SÜD Product Service GmbH, Ridlerstr. 65, 80339 München, Germany.
- 

Ergometer weight.
- 

Nationally Recognized Testing Laboratory NRTL label for the USA and Canada.
- 

Do not lean against the ergometer: there is a risk of the ergometer tipping over.
- 

Manufacturer's identification.
- 

Date of manufacture.
The number found under this symbol is the date of manufacture in the YYYY-MM-DD format.
- 

PVC-free.
- 

Latex-free.
- 

Suitable for indicated arm circumference.
- 

Small size.
- 

Standard size.
- 

Large size.
- 

Transport and storage label: top.
- 

Transport and storage label: keep dry.
- 

Transport and storage label: fragile.
- 

Transport and storage label: approved temperature range.
- 

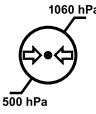
Transport and storage label: approved humidity, non-condensing.
- 

Transport and storage label: approved pressure range.
- 

Transport and storage label: do not stack.

SETUP AND MAINS CONNECTION

CONTROLS AND INDICATORS

- 1 Control terminal (model P or model K)
- 2 Blood pressure cuff connection (option)
- 3 Adjustment of the handlebar angle
- 4 Blood pressure cuff
- 5 Adjustment of the handlebar height (ergoselect 150/200 only)
- 6 Castors
- 7 Speed display (RPM) for patient
- 8 Adjustment of the saddle height (ergoselect 100/150 only)
- 9 Digital saddle height indication (ergoselect 200 only)
- 10 Power switch (green button)
- 11 Sockets for power cord and connection cables (underside of ergometer)
- 12 Levelling devices to adjust the ergometer to uneven floors

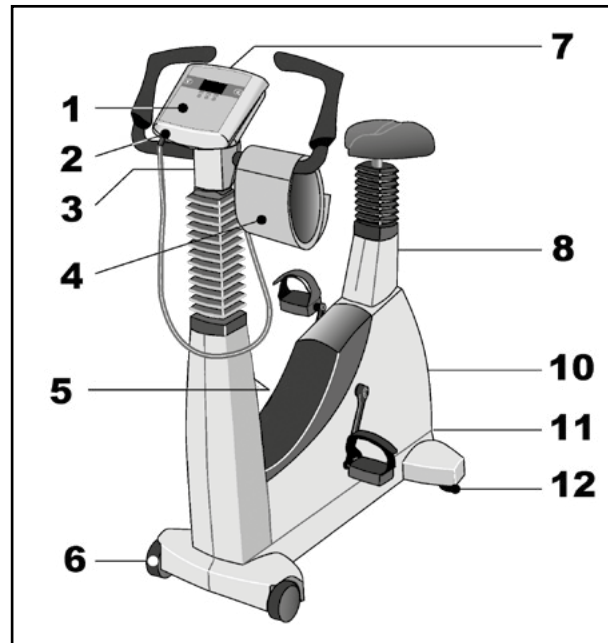

ERGOSELECT 100/150 – CONTROLS, CONNECTIONS AND INDICATORS

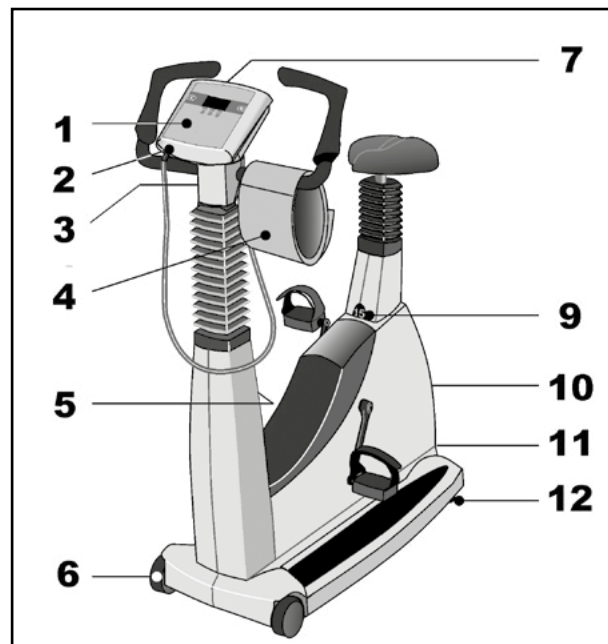

ERGOSELECT 200 – CONTROLS, CONNECTIONS AND INDICATORS

TRANSPORT

For short distances, the ergoselect can be lifted at the saddle and rolled away on its castors.

To cover greater distances, however, we recommend the following method:

- Disconnect the power cord from the wall outlet.
- Rotate the handlebar towards the front. Tighten the clamping lever.
- Stand in front of the ergoselect, grasp the handlebar and tilt the ergoselect towards you until it is standing on the castors only and is balanced.
- It is now possible to transport the ergoselect.
- When you have reached the new location, lower the ergoselect very carefully to avoid damage.

Caution

- Equipment Damage •

Avoid strong vibrations of the ergoselect during transport.



TRANSPORTING THE ERGOSELECT

SETUP

Place the ergoselect on a horizontal level floor.

The ergoselect must be set up in a secure and stable position - the two levelling feet at the back make for easy adjustment to uneven floor surfaces. Extend the foot concerned until the ergoselect no longer wobbles.

In case of delicate flooring, it is recommended to place a mat under the ergometer to protect the flooring from damage by the feet.

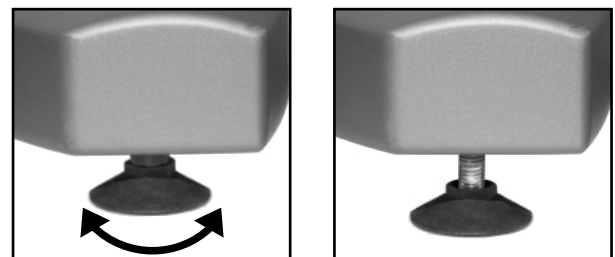

LEVELLING FEET OF THE ERGOSELECT ERGOMETER

MOUNTING THE CONTROL TERMINAL (P OR K)

The control terminal can be installed with the display either facing the patient or the operator.

It is recommended to install the terminal with the display and control keys towards the operator and the speed display towards the patient.

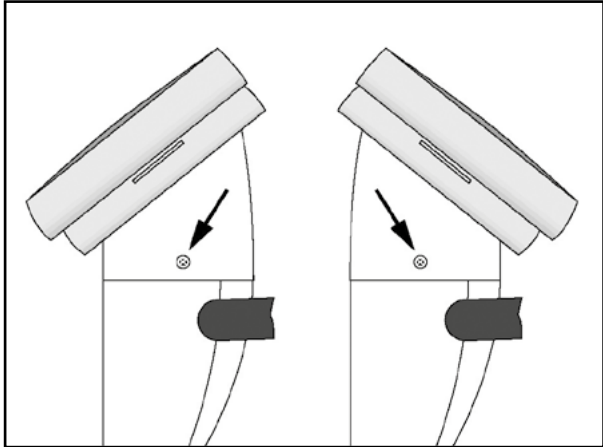

DIFFERENT ORIENTATIONS OF THE CONTROL TERMINAL

CONNECTING THE POWER CORD

Set the handlebar to the front upper position and secure. Tilt the ergoselect carefully towards you until it rests on the handlebar.



ASSEMBLY POSITION OF THE ERGOSELECT ERGOMETER

Caution

- Equipment Damage •

Before connecting the ergometer to the power line, check that the line voltage corresponds to the ratings on the type plate. The type plate is located on the back of the ergometer, at the bottom.

The connection panel is located on the underside of the ergometer.

- Plug the power cord into socket (a) and use the supplied lock (b) to secure it against disconnection.
- Using the supplied strain relief, attach the cable to the metal frame.

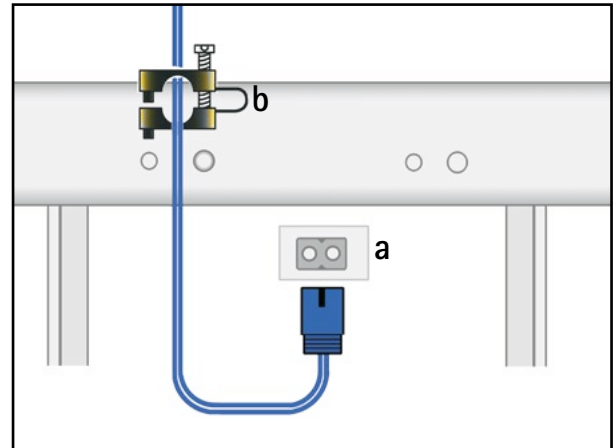

CONNECTION PANEL

a Power input

b Lock

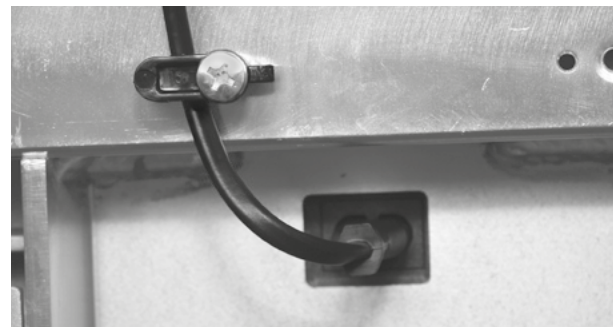

POWER CORD WITH INSTALLED STRAIN RELIEF

Caution

- **Disconnection from Power Supply** •

Pressing the power switch or removing the power cord disconnects the device from the power supply.

Removing the power cord results in a complete disconnection from the power supply (all poles).

Ensure that the power plug is readily accessible at all times.

CONNECTING THE ECG CABLE

ergoselect ergometers can be connected to electrocardiographs and PC-based ECG systems of most manufacturers.

Different connection cables are available to support different communication modes (digital, analog, remote start, etc.).

All ergoline ergometers are equipped with a digital interface (special adapters, which can be obtained from ergoline, are required for control of the ergometer with analog signals or for the remote start function).

The appropriate cable is plugged into the 9-pole port of the connection panel (Port 1) or into the USB port and secured at the metal frame with an additional strain relief.



EKG / PC CONNECTION

<i>USB</i>	<i>PC connection via USB (virtual COM)</i>
<i>PORT 1</i>	<i>Digital connection (remote control from PC or ECG recorder), connection for cable adapter (analog interface + remote start)</i>

Hint

- **connecting cables** •

Only use connecting cables released by ergoline.

To use the integrated USB connector, a special driver is required - contact ergoline.

CONNECTING THE BLOOD PRESSURE CUFF

- Connect the microphone at (1).
- Slip the cuff tubing onto the fitting (2) and engage. To disconnect, push back the connector's knurled sleeve.

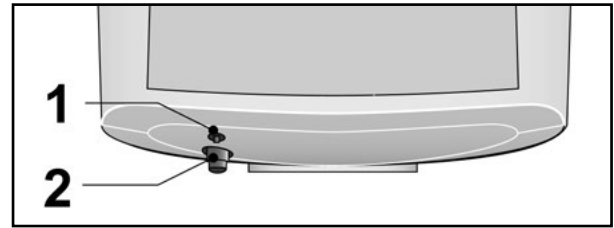

BLOOD PRESSURE CUFF CONNECTIONS

- 1 *Microphone connection*
- 2 *Cuff tubing*

Artifacts that may be caused by patient movements during the exercise test, must be avoided if possible, while the blood pressure is being taken. Therefore, do not forget to attach the cuff tubing to the handlebar with the supplied Velcro tape:

- Open the large Velcro tape and wrap around handlebar.
- Secure the cuff tubing with the small Velcro tape, but do not exert pressure on the tubing.

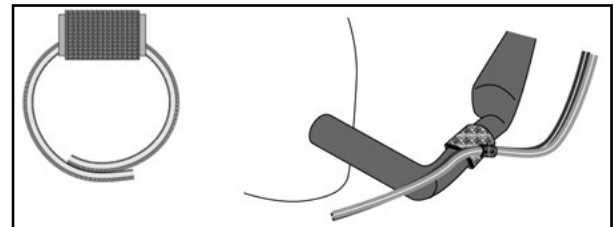

VELCRO TAPE TO SECURE THE CUFF TUBING

PREPARING THE PATIENT

ADJUSTING THE SADDLE AND THE HANDLEBAR

On the ergoselect 100/150, you adjust the saddle height manually with a clamping lever. On the ergoselect 200, the saddle height is electrically adjusted with the corresponding keys on the control terminal (the display below the saddle indicates the saddle height).

With the pedal in the bottom position, the angle between the axis formed by the upper body and the thigh should be approximately 10°.

Set the handlebar to a position where the patient sitting upright on the saddle can reach it easily.

To do so, open clamping lever 1 and set the handlebar to a suitable angle.

On the ergoselect 150/200, the height of the handlebar can additionally be adjusted with clamping lever 2 – the horizontal bar should be approximately at the same level as the saddle.

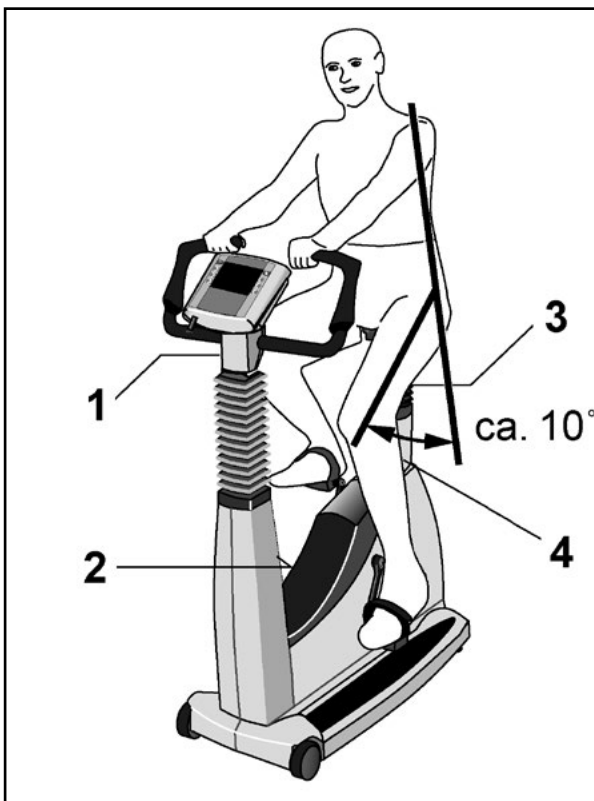

ADJUSTING SADDLE AND HANDLEBAR

- 1 Adjustment of the handlebar angle
- 2 Adjustment of the handlebar height (ergoselect 150/200 only)
- 3 Adjustment of the saddle height (ergoselect 100/150 only)
- 4 Saddle height display (ergoselect 200 only)

Note

- Tighten the clamping levers only as far as necessary, *NOT* with maximum force.
- Lubricate the clamping lever threads quarterly at minimum, using a suitable lubricant (e.g. OKS470).

PREPARING THE PATIENT FOR BLOOD PRESSURE MEASUREMENTS

CUFF SIZE

Always choose the cuff size suitable for the patient's arm. The maximum arm circumference is indicated on the cuff.

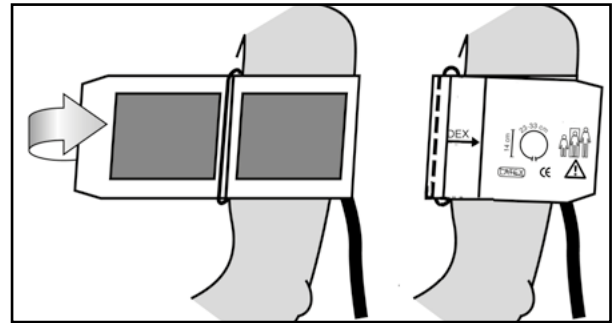

CORRECT CUFF SIZE

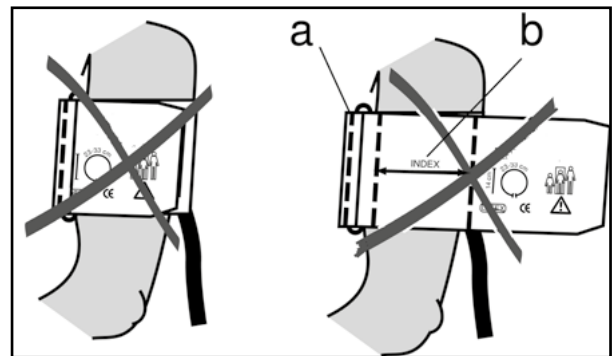

WRONG CUFF SIZE

MICROPHONE POSITION

Before applying the cuff, check the position of the microphone inside the red pocket (on the inside of the cuff): When the microphone is inside the pocket, its **metal side must face the arm**.

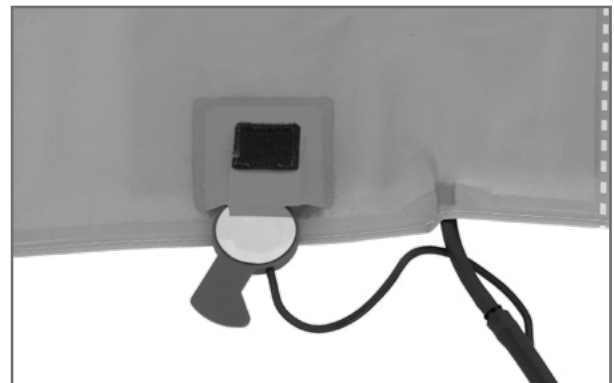

CORRECT MICROPHONE POSITION

APPLYING THE CUFF

The center of the microphone must be located exactly on the **brachial artery**. Locate the artery by palpation, if required. The **red tab** identifies the position of the microphone.

The accurate placement of the microphone is the primary condition for reliable pressure measurement during exercise tests.

The cuff must be applied directly on the skin, it may not be applied on top of clothing, paper, etc. Apply the cuff approx. **2 cm above the bend of the elbow**. The cuff should be **tight**, but it should not constrict blood vessels. The cuff **may not move** during the exercise test.

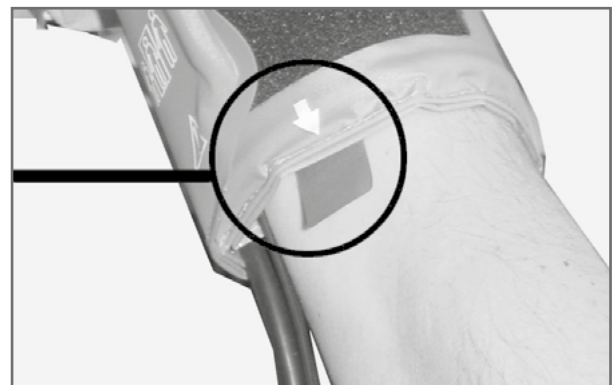

MICROPHONE PLACEMENT ON THE ARTERY

When you close the Velcro strap, check that the metal clasp (a) is inside the marked index range (b), and not outside.

The cuff tab must be located below the metal clasp (see illustration at right).

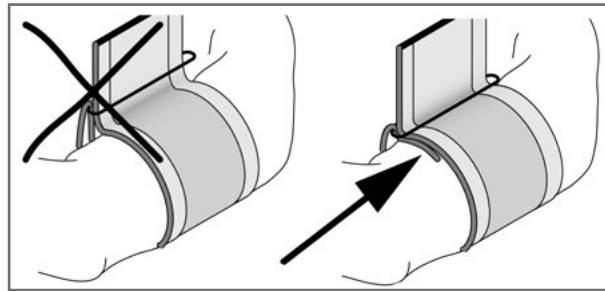

CORRECT CUFF POSITION (TAB)

CHECKING THE CUFF TUBING

Check that the cuff tubing does not knock against the patient's knee, when the patient is pedalling and the hand is on the handlebar.

Secure the cuff tubing with the Velcro tape attached to the handlebar.

Instruct your patient to move as little as possible during a blood pressure measurement and, in particular, to avoid excessive contractions of the muscles in the upper arm.



DISTANCE BETWEEN KNEE AND TUBING

Caution

- Patient Hazard •

Apply the cuff directly on the skin. Make sure that rolled up sleeves do not impede blood circulation in the upper arm.

Loose cuffs will cause erroneous measurements; overtight cuffs may constrict blood vessels or cause skin lesions and hematomas.

- Incorrect Measurements •

A loose cuff would degrade the accuracy of the measurement.

Therefore, the computer aborts the measurement, if a minimum pressure is not attained within a few seconds.

Warning

- Patient Hazard •

If, by accident, an excessive pressure builds up inside the cuff, either remove the cuff immediately from the arm or disconnect the cuff tubing from the control terminal.

The same measures are recommended, if the cuff does not deflate correctly.

OPERATION

The ergometers of the ergoselect series are available with two versions of the control terminal whose functionalities differ.

The following sections describe the control and configuration of the ergometer.



Control terminal P



Control terminal K

CONTROL TERMINAL P

TURNING THE SYSTEM ON

You turn the ergometer on by pressing the power switch - the green indicator in the switch lights up. The ergometer runs a self-test. Subsequently, the main menu displays.

Note

- *Instruct the patient not to pedal while the ergometer is being turned on and during the self-test.*
- *Apply the blood pressure cuff to the patient AFTER the ergometer has been turned on and the self-test completed.*
- *The device can be configured to default to one of the operating modes. If this option is selected, the initial screen of the selected operating mode (e.g. Ergometry) will be displayed instead of the main menu. With the  key, you can display the main menu.*



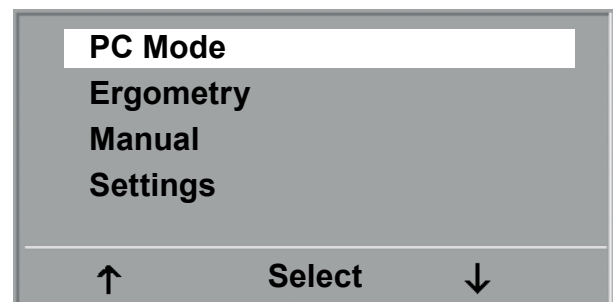

SELF-TEST SCREEN



MAIN MENU

The ergometer software is controlled with 5 keys:

 With this key you display the main menu or return to the previous menu level.

 With this key you initiate a blood pressure measurement. A measurement in progress can be aborted with the same key.

 The functions of these three softkeys change with the displayed menu - the key label describing the function is shown on the display.

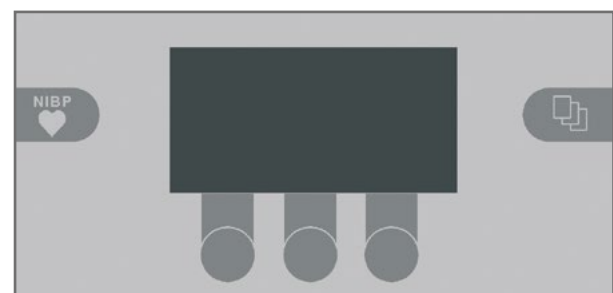

KEYPAD P

OPERATING MODES WITH CONTROL TERMINAL P

An ergoselect ergometer with a control terminal P supports the following operating modes:

PC MODE

An external device (e.g. stand-alone electrocardiograph, PC-based ECG system) controls the ergometer - no intervention at all is required at the ergometer.

ERGOMETRY

The ergometer runs an automatic exercise test - some of the corresponding test protocols are user-configurable and stored in the system (see chapter "Settings").

MANUAL

The ergometer is controlled manually, i.e., the user performs all load changes via the keypad.

SETTINGS

Used to configure the ergometer.

SPEED READOUT

At the top of the control terminal, there is a speed readout for the patient as well as three LEDs that inform the patient of the speed: too slow, too fast or correct.



The ranges for the respective speed ratings depend on the selected load (see "Technical Specifications").



SPEED READOUT

- 1 speed low (patient should pedal faster)
- 2 correct speed
- 3 speed high (= patient should pedal slower)

Note

- If, during an exercise test, the speed drops below 30 RPM, the load readout starts blinking on the display.
- To reactivate the saddle height adjustment function, press  and the arrow keys will again be displayed.
- Additional blood pressure measurements can be initiated with .

PC Mode

Use the softkeys on the right and left (↑ ↓) to position the bar cursor on PC MODE and confirm the selection with SELECT.

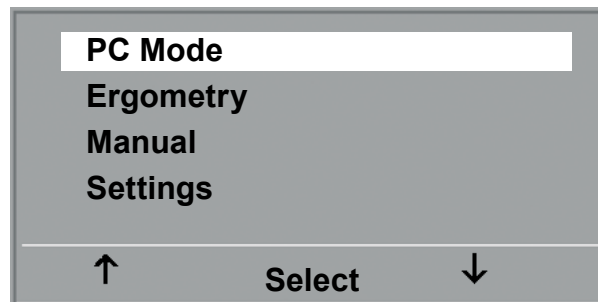

MAIN MENU

The display changes - the ergometer is waiting for commands from the external ECG unit.

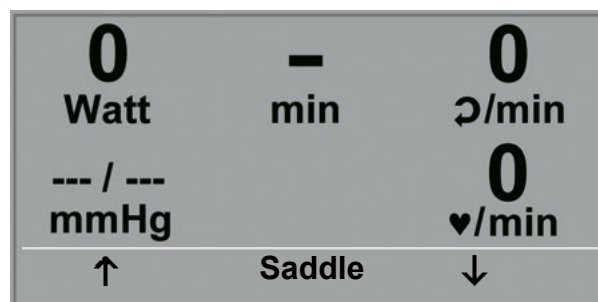

INITIAL SCREEN

With the arrow keys, the saddle height can be electrically adjusted on the ergoselect 200 (on the ergoselect 400, these keys adjust the height of the drive unit).

As soon as the ergometer receives commands from the controlling ECG unit or PC, the exercise test will start and the corresponding values will be displayed.

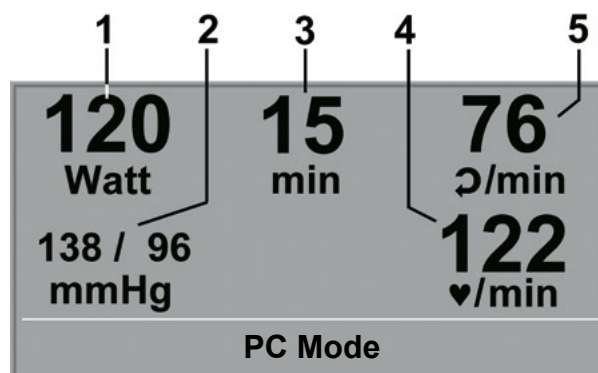



The exercise test can only be terminated with the corresponding command from the controlling ECG unit.

DISPLAY DURING EXERCISE TEST

- 1 current load in watts
- 2 most recent BP value (systolic/diastolic values) or cuff pressure during inflation and bar graph indicating microphone signal strength (see below)
- 3 duration of exercise test (min)
- 4 heart rate at the time of the BP measurement (BPM)
- 5 pedal speed (RPM)

Note

- All functions are locked while the ergometer is operating in PC mode, except for the saddle height adjustment and the blood pressure key.
- To reactivate the saddle height adjustment function, press  and the arrow keys will again be displayed.
- Additional blood pressure measurements can be initiated with .



ERGOMETRY

Use the softkeys on the right and left (↑ ↓) to position the bar cursor on ERGOMETRY and confirm the selection with SELECT.

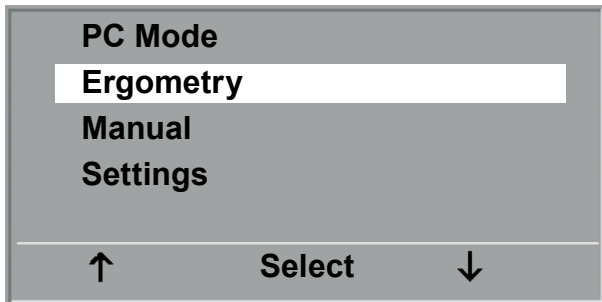

MAIN MENU

The stored test protocols available for selection will be displayed. There are five fixed protocols (protocols 1 to 5, see Appendix), whereas protocols 6 to 15 are user-programmable.

The protocol menu provides an overview of the test phases:

e.g.: **50 W / 2 min / 25 W**
 means: initial (basic) load 50 watts
 stage time 2 minutes
 load increment 25 watts

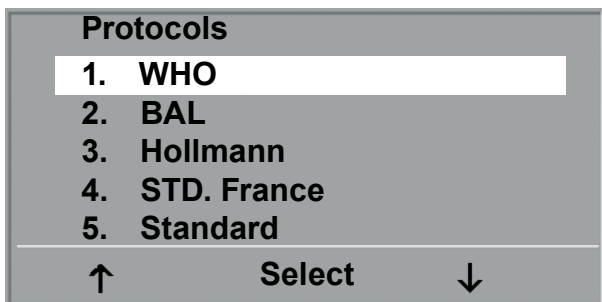

SELECTING AN EXERCISE TEST PROTOCOL

Use the softkeys on the right and left (↑ ↓) to position the bar cursor on one of the protocols and confirm the selection with SELECT.

The exercise test is started with the "Start" key, a blood pressure measurement at rest may precede the test (see "Settings").

When the basic load appears on the display (after approx. 15 seconds or upon termination of the blood pressure measurement) and the patient's RPM indicator blinks, the patient should start pedalling.



INITIAL EXERCISE TEST SCREEN



The internal protocol will now control the entire exercise test - the display always indicates the current values.

With the +5 W and -5 W keys, the current load can be changed at any time (in increments of +/-1 W up to +/-25 W, as configured).



SCREEN DISPLAY DURING THE TEST

Note

- The saddle height (ergoselect 200) can be changed during an exercise test.
- To reactivate the saddle height adjustment function, press  and the arrow keys will again be displayed.
- Additional blood pressure measurements can be initiated with .

TERMINATING AN EXERCISE TEST

The exercise phase can be terminated manually at any time with the RECOVERY key.

The load will immediately be reduced to 25 watts, but a higher or lower value can be selected manually.

It is recommended that the patient continues to pedal in the recovery phase.

The END key in the middle will terminate the test.



RECOVERY PHASE

MANUAL

Use the softkeys on the right and left (↑ ↓) to position the bar cursor on MANUAL and confirm the selection with SELECT.

In this operating mode the user controls the entire exercise test by selecting the loads, stage times and by initiating blood pressure measurements.

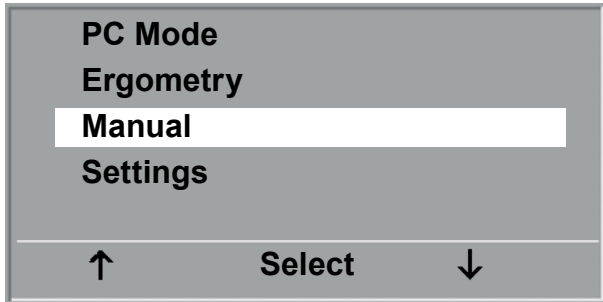

MAIN MENU

The exercise test is started with the "Start" key, afterwards the load can be set and changed with the +5 W and -5 W keys (in increments of +/-1 W up to +/-25 W, as configured).

Blood pressure measurements can be initiated with .



INITIAL SCREEN OF A MANUAL EXERCISE TEST

TERMINATING AN EXERCISE TEST

The exercise test can be terminated manually at any time with the END key located in the middle.

The load will immediately drop to 0 watt.

There is no recovery phase in the manual mode.



SCREEN DISPLAY DURING THE TEST

SETTINGS WITH CONTROL TERMINAL P

Some of the device settings are configurable to meet specific requirements. The settings will be saved and remain stored even when the ergometer is switched off.

Use the softkeys on the right and left (↑ ↓) to position the bar cursor on **SETTINGS** and confirm the selection with **SELECT**.

The configuration menu displays.

When all changes have been made, you can exit the configuration menu with the  key.

Use the softkeys on the right and left (↑ ↓) to position the bar cursor on the parameter to change and confirm the selection with **SELECT**.

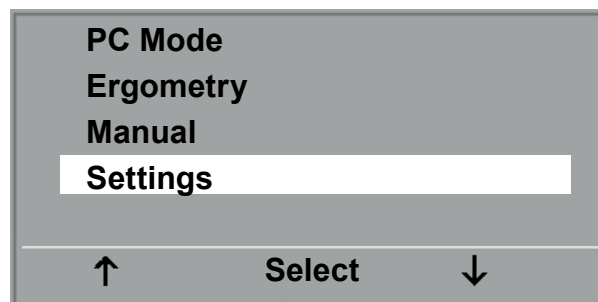

MAIN MENU

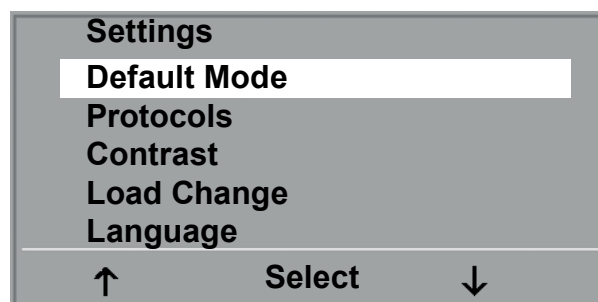

CONFIGURATION MENU

DEFAULT MODE

In this menu you choose the default mode activated when the ergometer is turned on. When first turned on, the ergometer will display this menu.

Use the softkeys on the right and left (↑ ↓) to position the bar cursor on your preferred default mode and save the selection with **SELECT**.

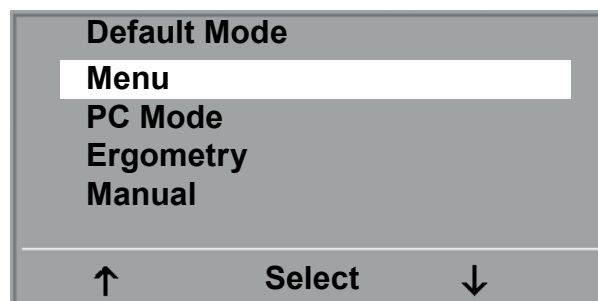

SELECTING THE DEFAULT MODE

PROTOCOLS

Protocols 6 - 15 are user-programmable (protocols 1 - 5 are fixed, see Appendix for protocol parameter details). Standard values for the following parameters can be entered:

- protocol type (step or ramp)
- initial load
- stage time
- load increment (load increase with each stage)

Use the softkeys on the right and left (↑ ↓) to position the bar cursor on the protocol to change (No. 6 - 15) and confirm the selection with **SELECT**.

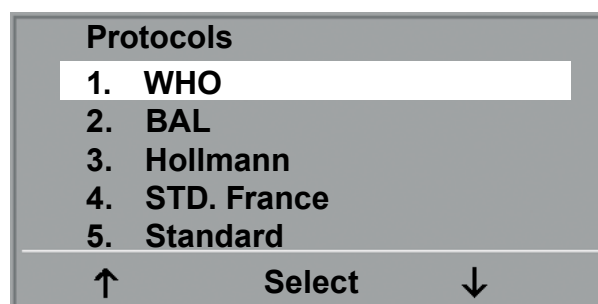

SELECTING THE EXERCISE TEST PROTOCOL TO EDIT

Use the softkeys \uparrow \downarrow to select the parameter to edit.

At Select, for example, you can choose the protocol type:

- Step (load increase in steps) or
- Ramp (continuous load increase).

Press SELECT to save the selected protocol type.

To cancel the selection, press the  key.

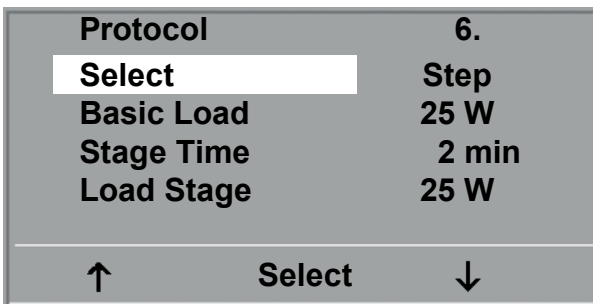

SELECTING THE PARAMETER TO EDIT

All other parameters are edited in the same way.

Using the arrow keys (\uparrow \downarrow), highlight a parameter and confirm the selection with SELECT: the corresponding value appears in reverse video and can be changed with the arrow keys \uparrow \downarrow .

Pressing SELECT will save the new value.

You exit the configuration with .

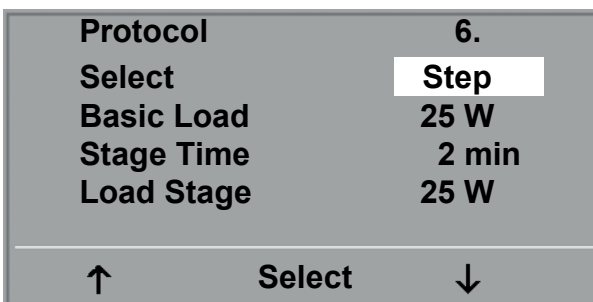

EDITING THE PARAMETER VALUE

CONTRAST

The display contrast is adjustable in the range from 0 to 100%.

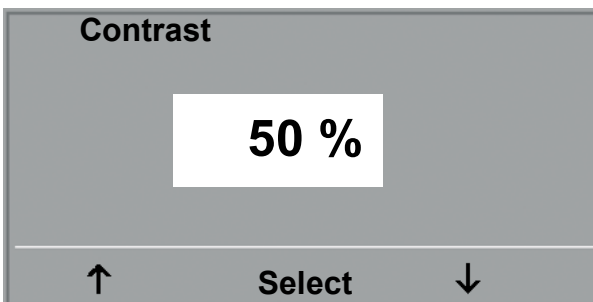

ADJUSTING THE DISPLAY CONTRAST

LOAD CHANGE

Here you determine the increments for each load change. Depending on your choice, each key press will change the load by +/- 1, 5, 10 und 25 Watts.

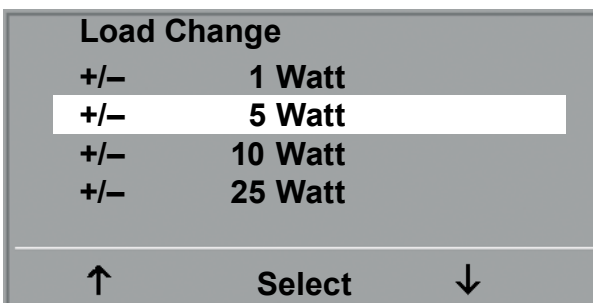

SELECTING THE INCREMENT FOR MANUAL LOAD CHANGES

LANGUAGE

The texts can be displayed in different languages.

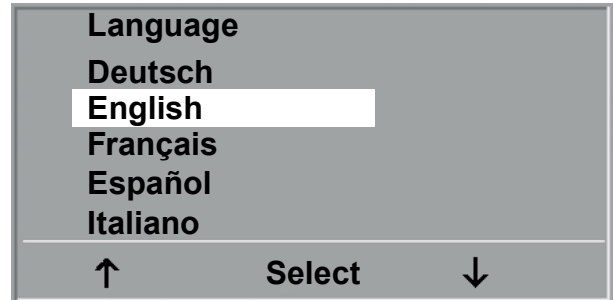

LANGUAGE MENU

BEEP

The audio signal emitted during blood pressure measurements can be turned on and off.

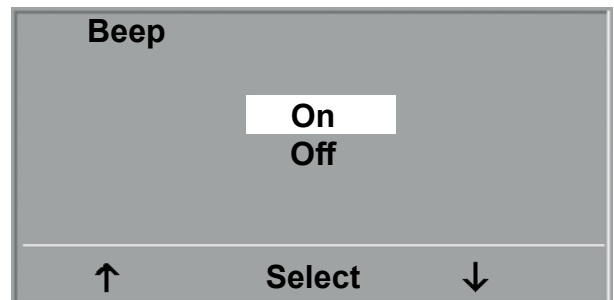

BEEP DURING BP MEASUREMENTS

SOFTWARE VERSION

Select this option to view the installed software version.

DATE/TIME

To begin with, you select DATE or TIME and confirm the selection. Then the value displayed in reverse video can be edited with the \uparrow \downarrow keys and saved with SELECT.

The time is adjusted in the same way.
You exit the configuration with .

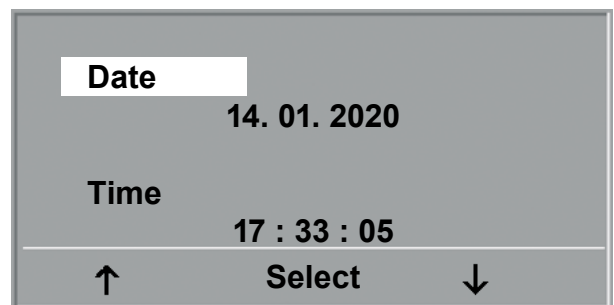

SETTING THE DATE

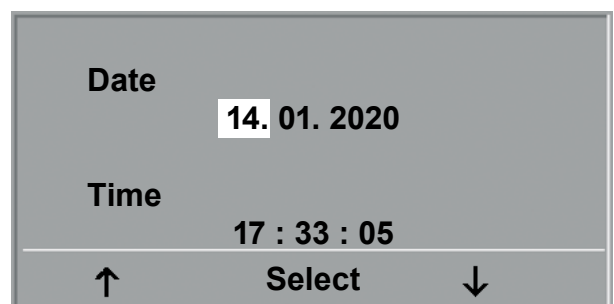

SETTING THE DAY

EKG TYPE

The selected EKG Type determines the communication method with the ECG recorder, PC-based ECG system, etc.

To prevent an accidental change of this setting, the menu is protected with a password.

Using the arrow keys, enter 003 and confirm the entry with SELECT.

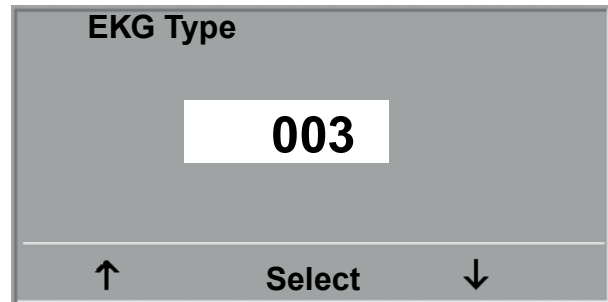

ENTERING THE EKG TYPE PASSWORD

All ergoselect ergometers support the following communication modes:

- **Analog with pulse**
Remote start mode; prior to each load change, the ergometer generates a control pulse and sends the corresponding data via the interface.
- **Analog / Digital**
An analog voltage controls the load - blood pressure measurements can be initiated with digital commands.
- **Digital (default)**
The communication with the ergometer is entirely controlled with digital commands.
- **Analog IN-OUT**
The entire communication (load control and BP measurements) is controlled with analog signals. No digital data will be sent.

Select the communication mode and confirm with SELECT.

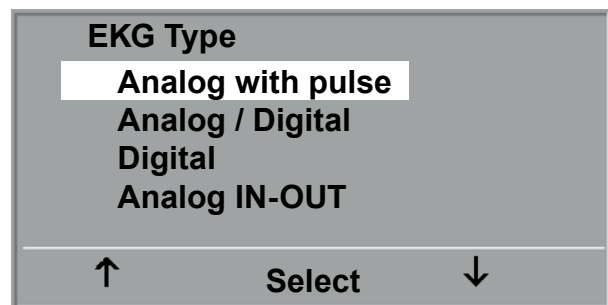

SELECTING THE ERGOMETER COMMUNICATION MODE

Note

- *The EKG Type needs to be selected only when the ergometer is connected to an ECG unit. The selection is part of the installation procedure.*
- *The "Analog/Digital" and "Digital" communication is only possible when PC Mode is selected from the main menu or when this is the default mode.*

RPM

Here you determine the RPM limits. When these limits are exceeded, the LEDs for high or low speed (RPM) will illuminate.

Select the value to change (Min. or Max.) and confirm with SELECT.

Using the arrow keys, change the value and save the new value with SELECT.

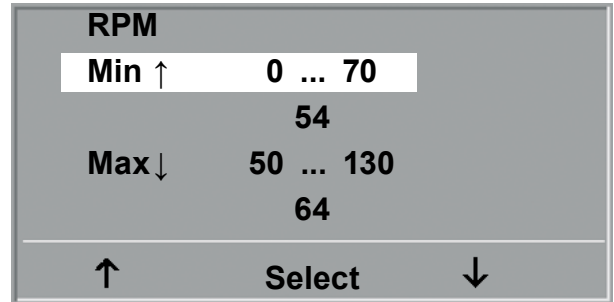

SETTING THE RPM LIMIT VALUES

Note

- *The limits selected in this menu only apply to the load range between 6 and 150 watts. At higher loads the RPM limits automatically adapt to the respective loads:*

Load (watts)	Green RPM range (1/min)
6 - 150	54 - 64 (adjustable)
151 - 250	58 - 65
251 - 350	68 - 75
351 - 450	78 - 85
451 - 550	88 - 95
551 - 650	98 - 105
651 - 750	108 - 115
751 - 850	118 - 125
851 - 950	> 125
951 - 999	> 130

PULSE DISPLAY

The pulse readout on the display can be turned off.

CONTROL TERMINAL K

TURNING THE SYSTEM ON

You turn the ergometer on by pressing the power switch - the green indicator in the switch lights up. The ergometer runs a self-test. Subsequently, the main menu displays.



SELF-TEST SCREEN

Note

- *Instruct the patient not to pedal while the ergometer is being turned on and during the self-test.*
- *Apply the blood pressure cuff to the patient AFTER the ergometer has been turned on and the self-test completed.*
- *The device can be configured to default to one of the operating modes. If this option is selected, the initial screen of the selected operating mode (e.g. Ergometry) will be displayed instead of the main menu. With the  key, you can display the main menu.*

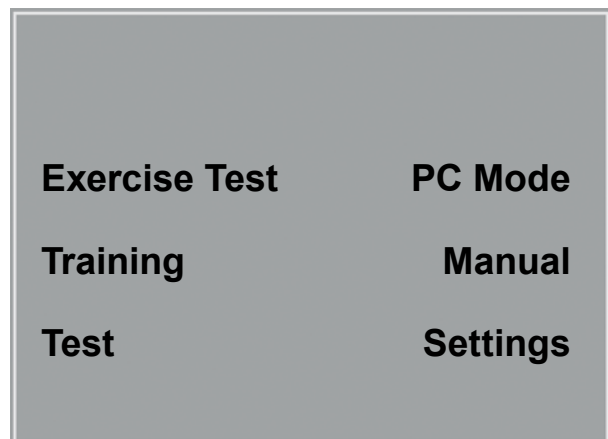

MAIN MENU

The ergometer software is controlled with 8 keys:

 With this key you display the main menu or return to the previous menu level.

 With this key you initiate a blood pressure measurement. A measurement in progress can be aborted with the same key.

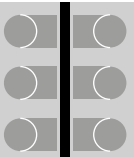
 The functions of these six softkeys change with the displayed menu - the key label describing the function is shown on the display.

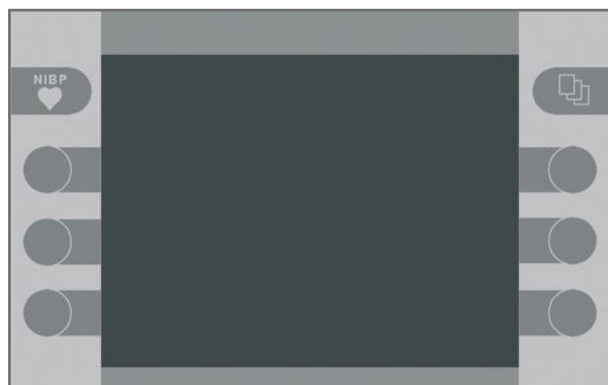

KEYPAD K

OPERATING MODES WITH CONTROL TERMINAL K

An ergoselect ergometer with a control terminal K supports the following operating modes:

PC MODE

An external device (e.g. stand-alone electrocardiograph, PC-based ECG system) controls the ergometer – no intervention at all is required at the ergometer.

ERGOMETRY

The ergometer runs an automatic exercise test – some of the corresponding test protocols are user-configurable and stored in the system (see chapter "Settings").

TRAINING

Ten different training protocols with warm-up, exercise and recovery phases can be custom-configured (see chapter "Settings").

A POLAR receiver is integrated in the ergometer and provides the relevant data for heart-rate controlled training sessions.

TEST

Integrated test protocols (steep ramping test, PWC tests) allow an assessment of the physical fitness.

MANUAL

The ergometer is controlled manually, i.e., the user performs all load changes via the keypad.

SETTINGS

Used to configure the ergometer.

SPEED READOUT

At the top of the control terminal, there is a speed readout for the patient as well as three LEDs that inform the patient of the speed: too slow, too fast or correct.



The ranges for the respective speed ratings depend on the selected load (see "Technical Specifications").



SPEED READOUT

- 1 speed low (patient should pedal faster)
- 2 correct speed
- 3 speed high (= patient should pedal slower)

Note

- If, during an exercise test, the speed drops below 30 RPM, the load readout starts blinking on the display.
- To reactivate the saddle height adjustment function, press  and the arrow keys will again be displayed.
- Additional blood pressure measurements can be initiated with .

PC MODE

When the PC Mode key has been pressed, the screen appears as shown at right. The ergometer is waiting for commands from the external ECG unit.

With the arrow keys, the saddle height can be electrically adjusted on the ergoselect 200 (on the ergoselect 400, these key adjust the height of the drive unit).

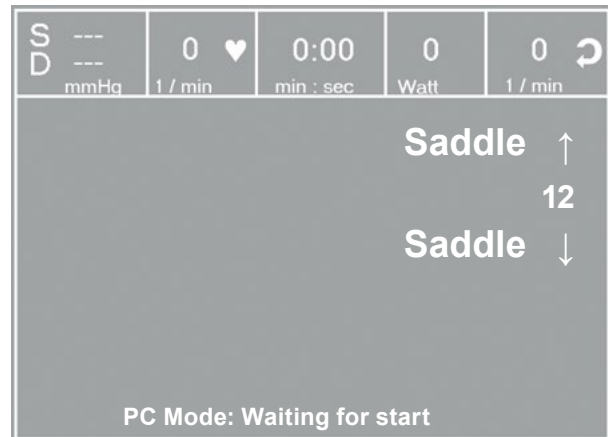

INITIAL SCREEN IN PC MODE

As soon as the ergometer receives commands from the controlling ECG unit or PC, the exercise test will start and the corresponding values will be displayed.

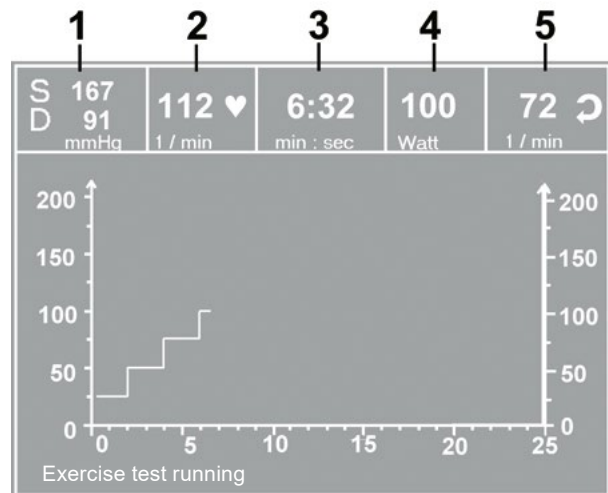

The exercise test can only be terminated with the corresponding command from the controlling ECG unit.



DISPLAY DURING EXERCISE TEST

- 1 most recent BP value (systolic/diastolic pressures) or cuff pressure during inflation and bar graph indicating microphone signal strength (see below)
- 2 SpO2 (%), heart rate (BPM)
- 3 duration of exercise test (minutes:seconds)
- 4 current load in watts
- 5 pedal speed (RPM)

Note

- All functions are locked while the ergometer is operating in PC mode, except for the saddle height adjustment and the blood pressure key.
- To reactivate the saddle height adjustment function, press  and the arrow keys will again be displayed.
- Additional blood pressure measurements can be initiated with .



ERGOMETRY

The ergometer is controlled by an internally stored protocol.

Pressing the "Ergometry" key will display the test protocol used last.

Press the "Start" key to re-start the protocol, or press the "Select" key to display the protocol parameters or to switch to another test protocol.

There are five fixed protocols (protocols 1 - 5, see Appendix), whereas protocols 6 - 15 are user-programmable.



INITIAL SCREEN OF AN EXERCISE TEST

With the arrow keys you can display the test protocol. With "Select" you confirm the selection.

The selected exercise test is started with the "Start" key, a blood pressure measurement at rest may precede the test (see "Settings").

The display changes to the exercise test screen, where load and heart rate are represented both by numeric values and waveforms.

When the basic load appears on the display (after approx. 15 seconds or upon termination of the blood pressure measurement) and the patient's RPM indicator blinks, the patient should start pedalling.

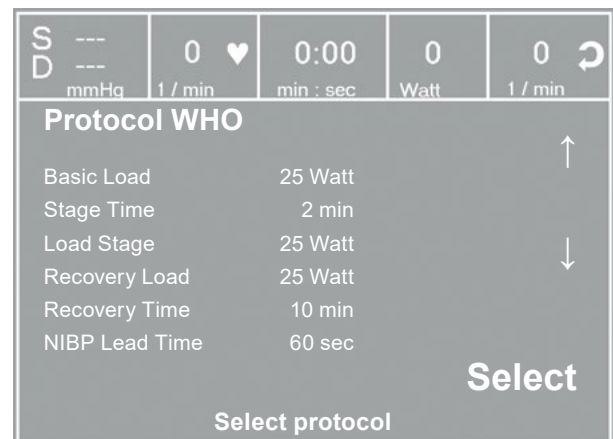

SELECTING THE TEST PROTOCOL

The internal protocol will now control the entire exercise test - the display always indicates the current values.

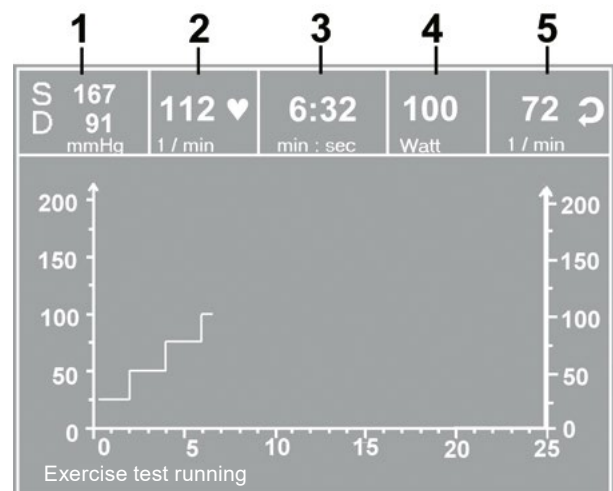

DISPLAY DURING EXERCISE TEST

- 1 most recent BP value (systolic/diastolic pressures) or cuff pressure during inflation
- 2 heart rate (BPM)
- 3 duration of exercise test (minutes:seconds)
- 4 current load in watts
- 5 pedal speed (RPM)

ADJUSTMENTS DURING THE EXERCISE TEST

Press the  key to display the configuration menu.

This is what you can do during the test

- increase or decrease the current load in increments (adjustable between 1 watt and 25 watts),
- hold the current load,
- end the exercise phase and advance to the recovery phase,
- terminate the test.

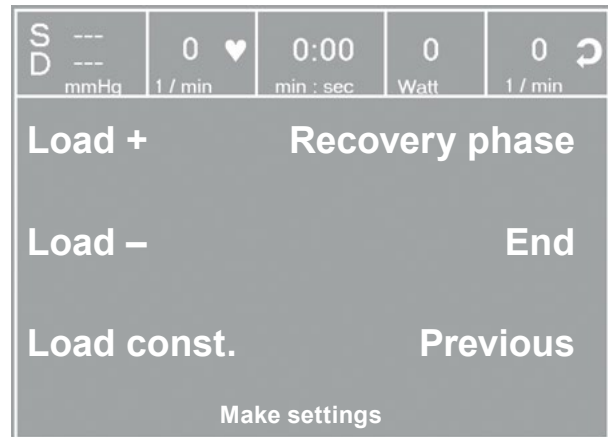

CONFIGURATION MENU I

Pressing  again displays another menu where you can change the saddle height and the display mode (see "PC Mode").

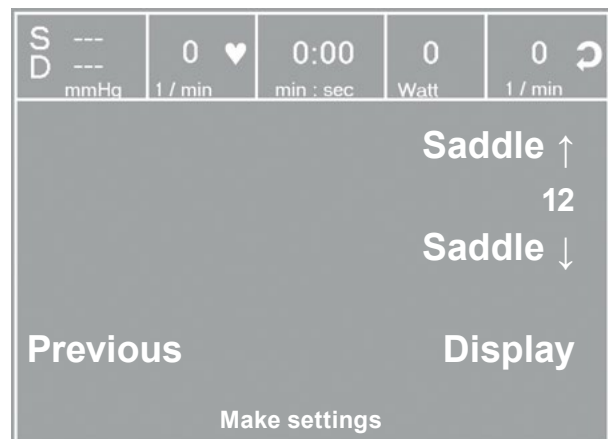

CONFIGURATION MENU II

TERMINATING THE TEST

Once the full protocol has been completed, the test will be terminated.

However, it is possible at any time to manually terminate the test or switch to the recovery phase (see above).

MANUAL

In this operating mode the user controls the entire exercise test by selecting the loads, stage times and by initiating blood pressure measurements.

The exercise test is started with the "Start" key, afterwards the load can be set and changed with the [Load +] and [Load -] keys (in increments of 1 W up to 25 W, as configured).

Blood pressure measurements can be initiated with .

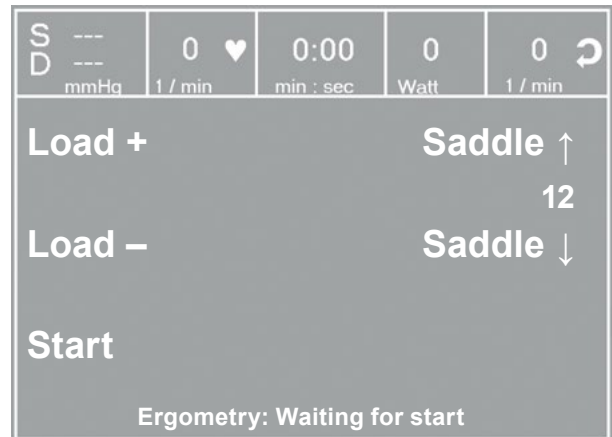

SCREEN DISPLAY IN MANUAL MODE

TERMINATING AN EXERCISE TEST

The exercise test can be terminated manually at any time with the END key located in the middle.

The load will immediately drop to 0 watt.

There is no recovery phase in the manual mode.

TRAINING

Cardiologic training sessions can be performed with ergo-select ergometers equipped with control terminal K. For a detailed description of the protocols, please refer to the Appendix.

Pressing the "Training" key will display the training protocol used last.

Press the "Start" key to re-start the protocol, or press the "Select" key to display the protocol parameters or to switch to another training protocol.

All training protocols 1 - 10 are user-configurable (see "Settings for Control Terminals K").

Use the arrow keys to display the protocol to use and the corresponding parameters. Confirm the selection with the "Select" key.

You initiate the training session with the "Start" key.

The display changes to the training session screen, where load and heart rate are represented both by numeric values and by waveforms.

When the basic load appears on the display (after approx. 15 seconds or upon termination of the blood pressure measurement) and the patient's RPM indicator blinks, the patient should start pedalling.

The internal protocol will now control the entire training session - the display always indicates the current values.

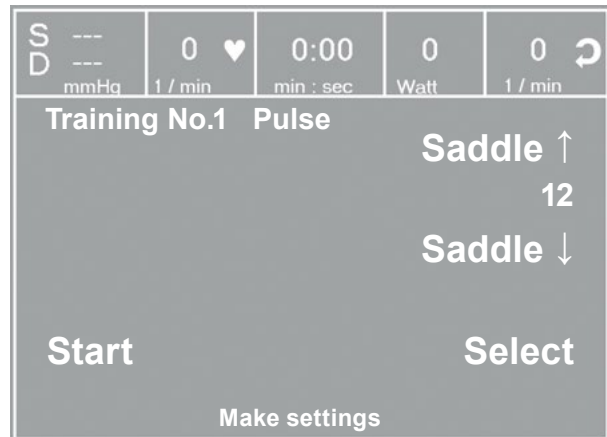

INITIAL SCREEN OF THE TRAINING SESSION

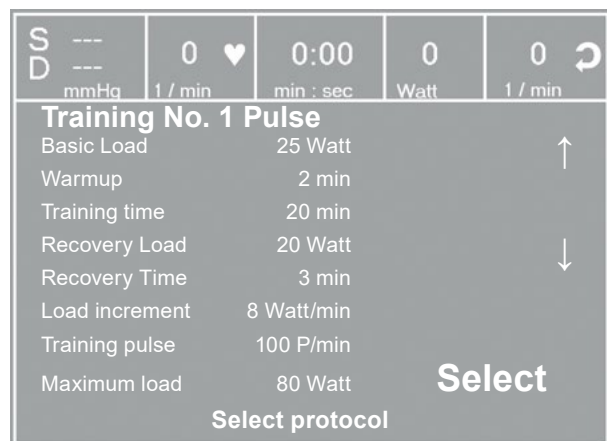

SELECTING THE TRAINING PROTOCOL

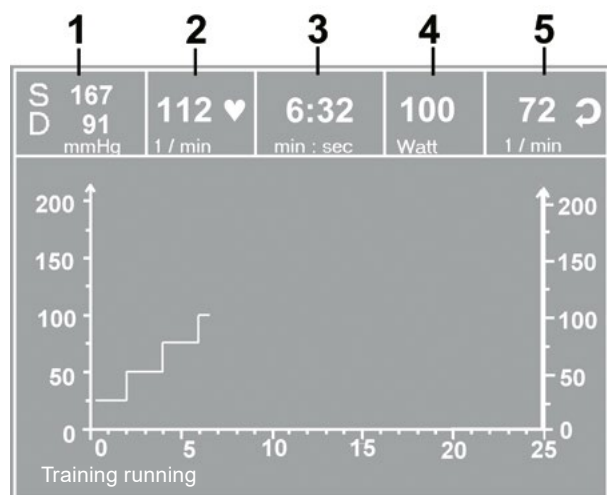

DISPLAY DURING EXERCISE TEST

- 1 most recent BP value (systolic/diastolic pressures) or cuff pressure during inflation
- 2 heart rate (BPM)
- 3 duration of exercise test (minutes:seconds)
- 4 current load in watts
- 5 pedal speed (RPM)

ADJUSTMENTS DURING THE TRAINING SESSION

Press the  key to display the configuration menu.

This is what you can do during the training session

- end the training session and advance to the recovery phase,
- directly terminate the training session,
- change the display mode (see "PC Mode").



CONFIGURATION MENU

TRAINING WITH CHIP CARD

As an alternative to the training protocols saved in the ergometer, it is possible to load training protocols from the chip card.

The training protocols are saved to the chip card by means of a PC program ("ergoline opticare professional" or "ergoline opticare basic").

Upon completion of the training session, the entire procedure (incl. load and heart rate waveforms) is saved to the chip card and can be reviewed and analyzed at the PC.

STARTING THE CHIP CARD TRAINING SESSION

Select the "Training" mode and insert the chip card into the card reader (on the side of the control terminal).

The ergometer switches to the chip card mode and reads the data stored on the card.

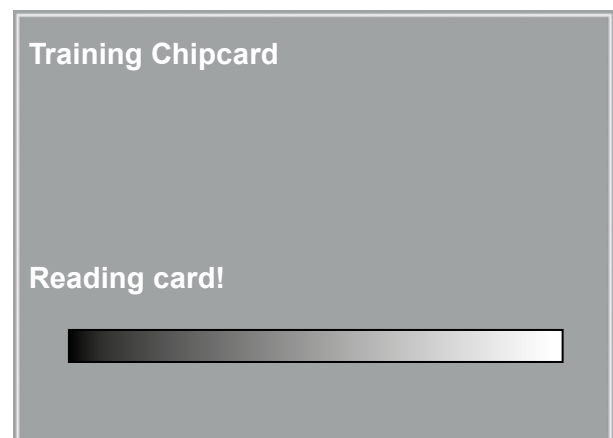

READING THE CHIP CARD DATA

The name and the weight stored on the card are displayed.

You can use the arrow keys to enter the current weight.

Press the "Next" key and the initial screen will display.
You can initiate the displayed training protocol or select another protocol from the chip card.

The chip card training session proceeds in the same way as the exercise tests stored in the ergometer.

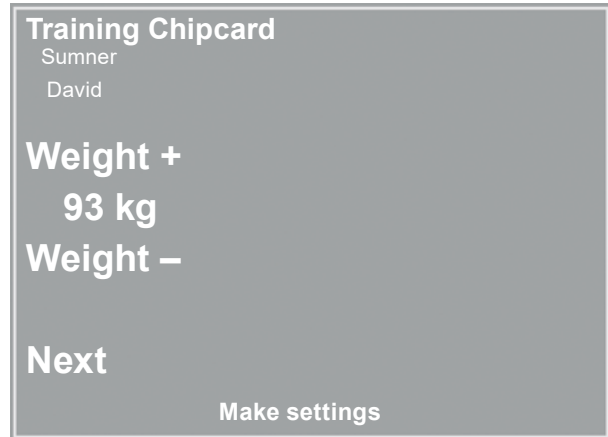

ENTERING THE WEIGHT

TERMINATING THE TRAINING SESSION

After termination of the training session (automatic termination when the programmed recovery phase has been completed, or manual termination) the test subject can state how the test was perceived (BORG scale).

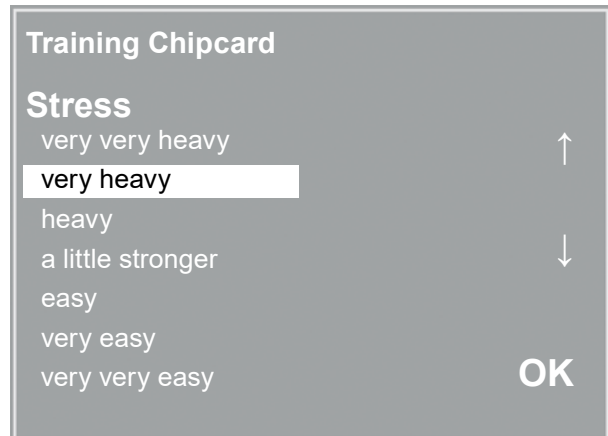

ENTERING THE BORG VALUE

Subsequently all training data are written to the chip card and are then available for analysis with a special program (e.g. opticare basic).

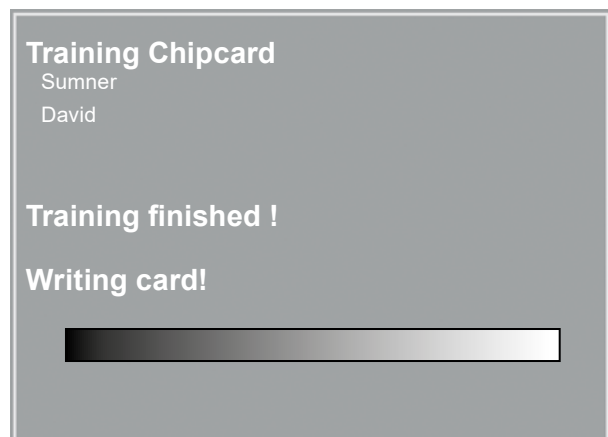

WRITING TO THE CHIP CARD

SETTINGS FOR CONTROL TERMINALS K

Some of the device settings are configurable to meet specific requirements. The settings will be saved and remain stored even when the ergometer is switched off.

Select **SETTINGS** to display the configuration menu.

When all changes have been made, you can exit the configuration menu with the  key.

Use the softkeys (↑ ↓) to position the bar cursor on the parameter to change and confirm the selection with **SELECT**.

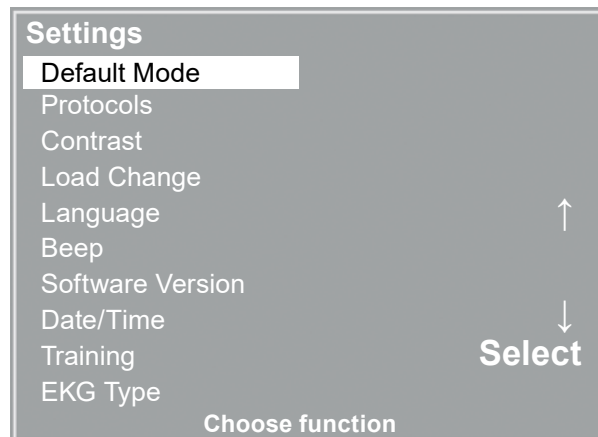

CONFIGURATION MENU

DEFAULT MODE

In this menu you choose the default mode activated when the ergometer is turned on. When first turned on, the ergometer will display this menu.

Use the softkeys (↑ ↓) to position the bar cursor on your preferred default mode and save the selection with **SELECT**.

PROTOCOLS

Protocols 6 - 15 are user-programmable (protocols 1 - 5 are fixed, see Appendix for protocol parameter details). Standard values for the following parameters can be entered:

- test protocol type (step/ramp)
- initial load
- stage time
- load increment (load increase with each stage)
- NIBP lead time (blood pressure measurement)
- recovery load
- recovery time

Use the softkeys (↑ ↓) to position the bar cursor on the protocol to change (No. 6 - 15) and confirm the selection with **SELECT**.

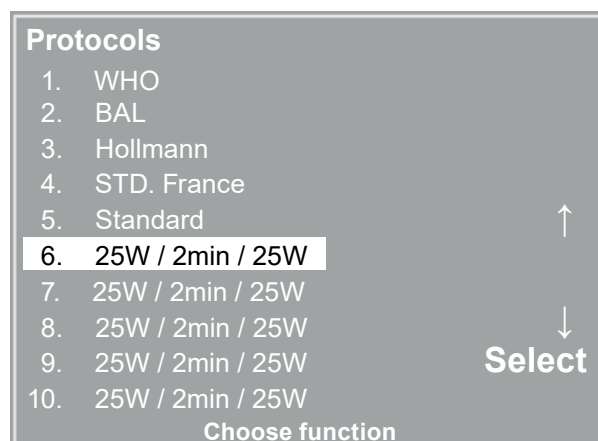

SELECTING THE EXERCISE TEST PROTOCOL TO EDIT

Use the softkeys $\uparrow \downarrow$ to select the parameter to edit.

At Select, for example, you can choose the protocol type:

- Step (load increase in steps) or
- Ramp (continuous load increase).

Press SELECT to save the selected protocol type.

To cancel the selection, press the  key.

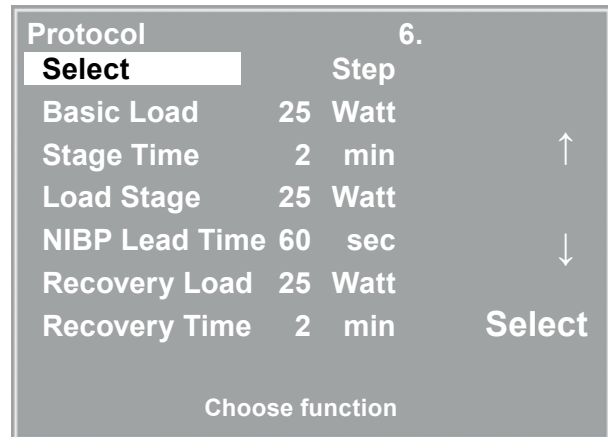

SELECTING THE PARAMETER TO EDIT

All other parameters are edited in the same way.

Using the arrow keys ($\uparrow \downarrow$), highlight a parameter and confirm the selection with SELECT: the corresponding value appears in reverse video and can be changed with the arrow keys $\uparrow \downarrow$.

Pressing SELECT will save the new value.

You exit the configuration with .

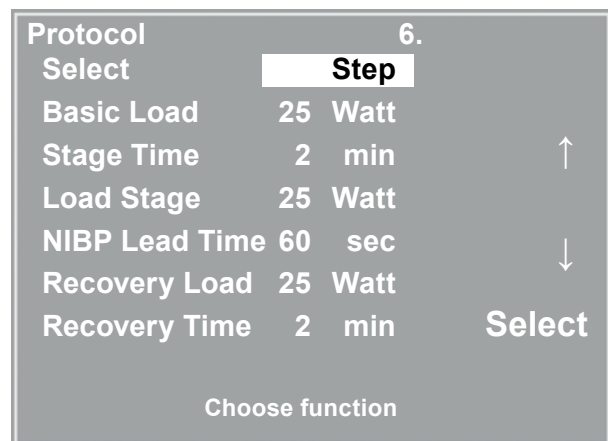

EDITING THE PARAMETER VALUE

CONTRAST

The display contrast is adjustable in the range from 0 to 100%.

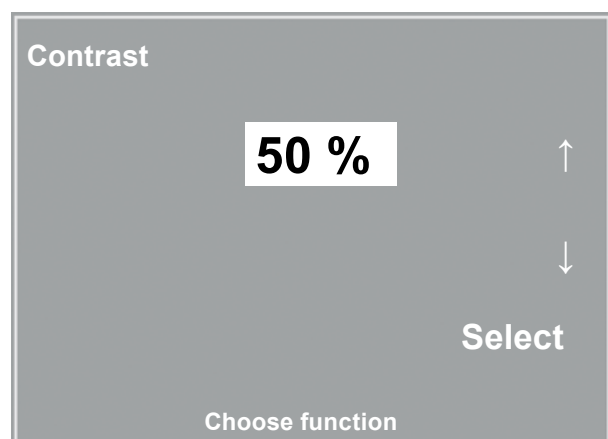

EDITING THE PARAMETER VALUE

LOAD CHANGE

Here you determine the increments for each load change. Depending on your choice, each key press will change the load by +/- 1, 5, 10 und 25 watts.

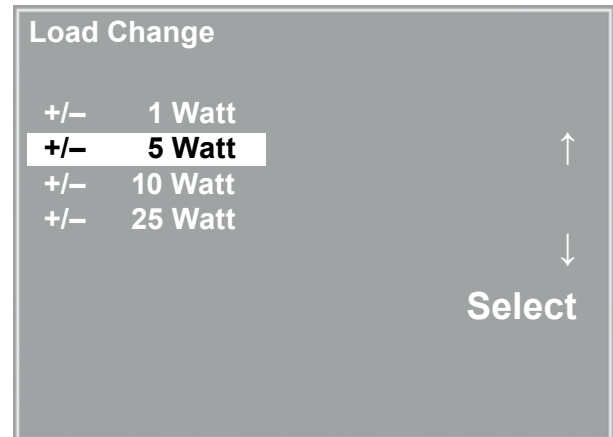

SELECTING THE INCREMENT FOR MANUAL LOAD CHANGES

LANGUAGE

The texts can be displayed in different languages.

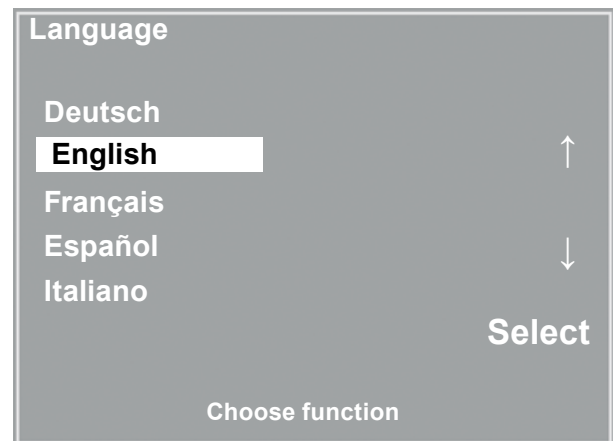

LANGUAGE MENU

BEEP

The audio signal emitted during blood pressure measurements can be turned on and off.

SOFTWARE VERSION

Select this option to view the ergometer's installed software version.

DATE/TIME

To begin with, you select DATE or TIME and confirm the selection.

Then the value displayed in reverse video can be edited with the ↑ ↓ keys and saved with SELECT.

The time is set in the same way.

You exit the configuration with .

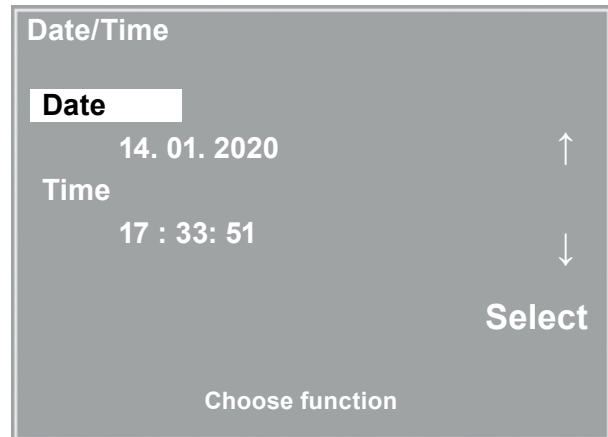

Date/Time

Date
14. 01. 2020 ↑

Time
17 : 33: 51 ↓

Select

Choose function

SETTING THE DATE

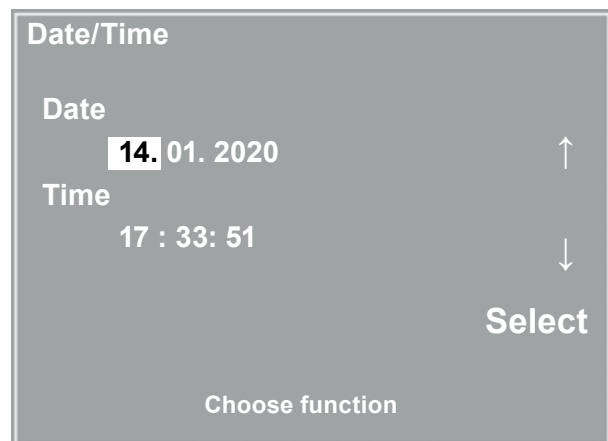

Date/Time

Date
14. 01. 2020 ↑

Time
17 : 33: 51 ↓

Select

Choose function

CHANGING THE DATE

TRAINING

Ten training protocols consisting of warmup, training and recovery phase are user-configurable. Depending on the selected training mode (pulse, constant, interval), there will be different parameters to define for the training phase:

First of all you select and confirm the protocol you wish to configure.

Then you select the parameters with the arrow keys (↑ ↓) as usual and edit them.

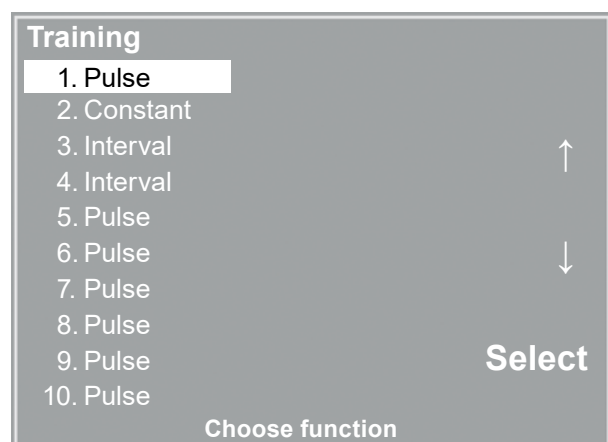

Training

1. Pulse ↑

2. Constant

3. Interval

4. Interval

5. Pulse ↓

6. Pulse

7. Pulse

8. Pulse

9. Pulse

10. Pulse

Select

Choose function

SELECTING THE EXERCISE TEST PROTOCOL TO EDIT

For all training modes (pulse, constant load and interval), the warmup phase, the duration of the training session and the recovery phase are defined first. Depending on the selected training mode, you can edit the corresponding parameters afterwards:

- **Pulse-controlled training:**
 Training pulse: 40 - 250 1/min
 Maximum load: 1 - 999 Watt
- **Constant load:**
 Training load: 1 - 999 Watt
- **Interval training:**
 Load Stage 1: 1 - 999 Watt
 Stage Time 1: 10 - 300 sec
 Load Stage 2: 1 - 999 Watt
 Stage Time 2: 10 - 300 sec

Training			
Select		Pulse	
Basic Load	20	Watt	
Warmup	2	min	↑
Training time	20	min	
Recovery Load	20	Watt	
Recovery Time	3	min	↓
Load increment	8	W/min	
Training pulse	100	1/min	
Maximum load	50	Watt	Select
Choose function			

EDITING THE TRAINING PROTOCOL

EKG TYPE

The selected EKG Type determines the communication method with the ECG recorder, PC-based ECG system, etc.

To prevent an accidental change of this setting, the menu is protected with a password.

Using the arrow keys, enter 003 and confirm the entry with SELECT.

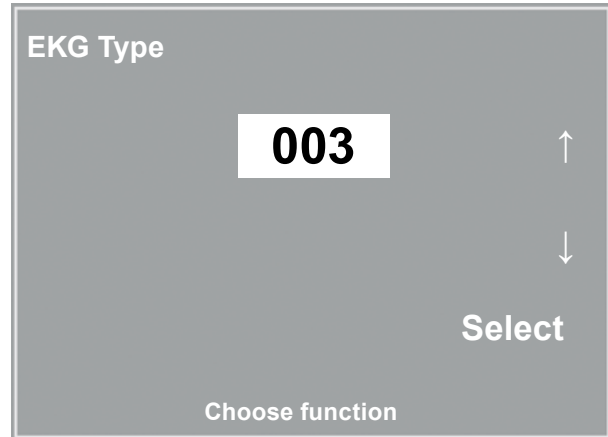

ENTERING THE EKG TYPE PASSWORD

All ergoselect ergometers support the following communication modes:

- Analog with pulse
Remote start mode; prior to each load change, the ergometer generates a control pulse and sends the corresponding data via the interface.
- Analog / Digital
An analog voltage controls the load - blood pressure measurements can be initiated with digital commands.
- Digital (default)
The communication with the ergometer is entirely controlled with digital commands.
- Analog IN-OUT
The entire communication (load control and BP measurements) is controlled with analog signals.
No digital data will be sent.

Select the communication mode and confirm with SELECT.

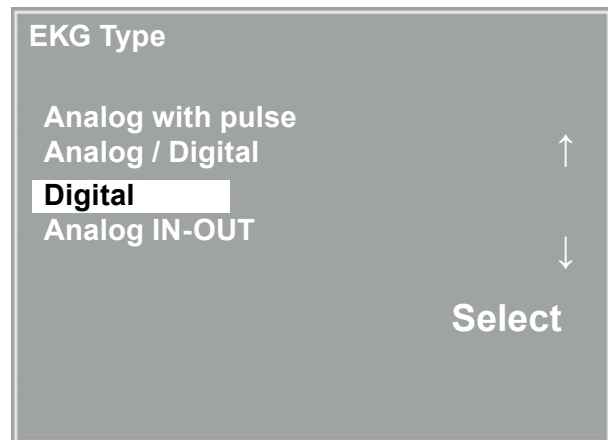

SELECTING THE ERGOMETER COMMUNICATION MODE

Note

- *The EKG Type needs to be selected only when the ergometer is connected to an ECG unit. The selection is part of the installation procedure.*
- *The "Analog/Digital" and "Digital" communication is only possible when PC Mode is selected from the main menu or when this is the default mode.*

RPM

Here you determine the RPM limits. When these limits are exceeded, the LEDs for high or low speed (RPM) will illuminate.

Select the value to change (Min. or Max.) and confirm with SELECT.

Using the arrow keys, change the corresponding value and save the new value with SELECT.

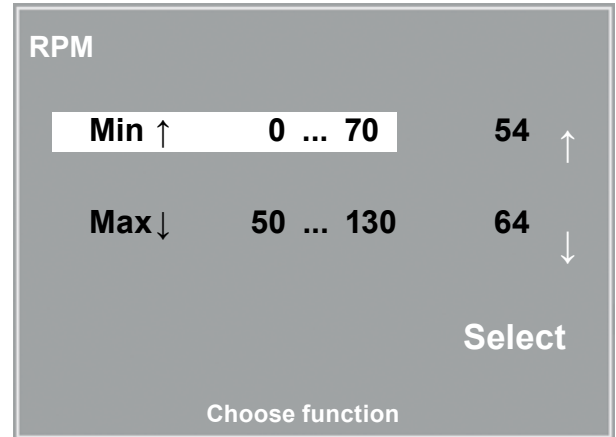

SETTING THE RPM LIMIT VALUES

Note

- *The limits selected in this menu only apply to the load range between 6 and 150 watts. At higher loads the RPM limits automatically adapt to the respective loads:*

Load (watts)	Green RPM range (1/min)
6 - 150	54 - 64 (adjustable)
151 - 250	58 - 65
251 - 350	68 - 75
351 - 450	78 - 85
451 - 550	88 - 95
551 - 650	98 - 105
651 - 750	108 - 115
751 - 850	118 - 125
851 - 950	> 125
951 - 999	> 130

PULSE DISPLAY

The pulse readout on the display can be turned off.

CLEANING, MAINTENANCE, DISPOSAL

GENERAL CLEANING

Wipe the device surface down with a cloth moistened with soap water or a disinfectant.

The cloth should not be dripping wet; do not allow liquids to enter the device.

CLEANING THE HANDLEBAR

After each training session, the handlebar should be disinfected with one of the disinfectants listed below.

CLEANING THE SADDLE

Clean the saddle with a soft and dry or moist cloth (**Disinfectants used should not contain any alcohol**).

CLEANING THE UPHOLSTERY (E.G. COUCH ERGOMETER)

Wipe the upholstery down with a soft cloth moistened with soap water.

The cloth should only be moist and not dripping wet.

If the cleaning agents and disinfectants used are caustic or contain alcohol, they may damage and/or discolor the upholstery.

DISINFECTION

Only the following disinfectants are approved for disinfection:

Schülke & Mayr GmbH:

- Antifect® AF, FF, FD 10
- Terralin® (0,5 %)
- Quartamon Med®

B. Braun Melsungen AG:

- Hexaquart plus® (0,5 % / 5,0 %)
- Hexaquart S® (1,5 % / 5,0 %)
- Meliseptol®
- Melsept SF® (0,5 % / 5,0 %)

ECOLAB:

- Incidin Foam®

Warning

- Shock Hazard •

- *Disconnect the device from the power line before cleaning.*

- Equipment Damage •

- *Do not allow liquids to enter the equipment. Devices into which liquids have entered must be immediately cleaned and checked by a service technician, before they can be reused.*

- *Do not use acids, alkaline solutions (household cleaners) or caustic disinfectants.*

Note

- *The use of cleaning agents and disinfectants containing alcohol is not permitted!*

Hint

- *Strictly observe the manufacturer's instructions for use.*

CLEANING THE BLOOD PRESSURE CUFF

REMOVING THE MICROPHONE

Pull the end of the cuff through the metal clasp and fold out the cuff.

Pull on the short Velcro tab to open the microphone pocket and carefully remove the microphone.

CLEANING

Clean the cuff and tubing with a moist cloth. You can use a dishwashing liquid or mild soap water (**no cleaning agents containing alcohol**).

Clean the microphone with a cloth moistened with alcohol or soap water. Allow the microphone to dry before reinserting it in its pocket.

DISINFECTION

For disinfection, spray a disinfectant sparingly on the cuff, the tubing and the microphone. After the contact time indicated by the manufacturer, wipe all components dry.

Only the following disinfectants are approved for disinfection:

Schülke & Mayr GmbH:

- Antifect® AF, FF, FD 10
- Terralin® (0,5 %)
- Quartamon Med®

B. Braun Melsungen AG:

- Hexaquart plus® (0,5 % / 5,0 %)
- Hexaquart S® (1,5 % / 5,0 %)
- Meliseptol®
- Melsept SF® (0,5 % / 5,0 %)

ECOLAB:

- Incidin Foam®

INSERTING THE MICROPHONE

Slip the microphone into the pocket, the metal side facing the arm.

Guide the microphone cable out of the pocket and to the right of the Velcro tab. Then close the tab.

Fold the end of the cuff over and introduce it into the metal clasp.

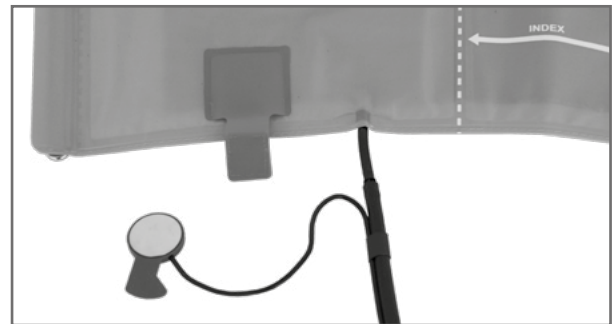

REMOVING THE MICROPHONE

Warning

- **Equipment Damage**
- *Cuff, microphone and tubing may not under any circumstances:*
 - be immersed in liquids
 - be cleaned in a water bath or in running water.

Hint

- *Strictly observe the manufacturer's instructions for use.*

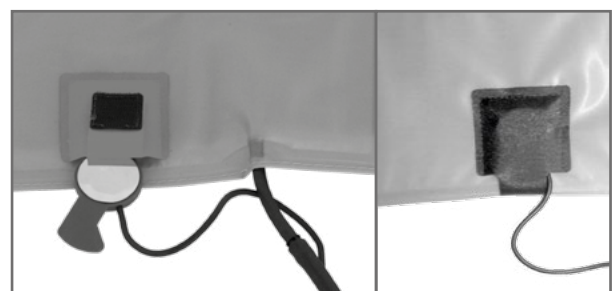

INSERTING THE MICROPHONE

MAINTENANCE

CHECKS BEFORE EACH USE

Before each use, visually inspect the device for signs of damage.

If you detect damages or impaired functions which may result in a hazard to the patient or the operator, the device must be repaired before it can be used again.

TECHNICAL SAFETY INSPECTIONS AND TECHNICAL INSPECTIONS OF THE MEASURING SYSTEM

The technical safety inspections and the inspections of the measuring system must be completed every two years according to the rules of the art by a Service Engineer authorized by ergoline.

Similarly, the automatic sphygmomanometer in the control terminal must be checked and calibrated by an authorized specialist every two years to fulfill legal requirements.

The date of the next inspection is indicated on the inspection sticker attached next to the type plate on the ergometer.

DISPOSAL

Do not dispose the product described in this Operator Manual as unsorted municipal waste. It must be collected separately.



Please contact the authorized manufacturer ergoline GmbH to obtain information concerning the decommissioning of your equipment. There is no proper waste management, proper disposal is documented by ergoline GmbH. Consult operating instructions.

TECHNICAL SPECIFICATIONS

ERGOMETER

Model	modular ergometer system ergoselect models ergoselect 100 P / K, ergoselect 150 P / K, ergoselect 200 P / K
Operating Mode	continuous operation
Power	100 - 240 V / 50 - 60 Hz (100 VA max.) specification power cord US: SPT 2x18AWG 125 V / 10 A "hospital" or "hospital grade" specification internal backup battery: IEC: CR 2032 /3V 230 mAh
Braking Principle	computer-controlled eddy current brake with torque measurement; speed independent to DIN VDE 0750-0238
Load Range	6 - 999 watts, speed independent (see diagrams)
Speed Range	30 to 130 RPM
Deviation of Measured Load	to DIN VDE 0750-0238
Load Increments	user programmable
Internal Protocols	Control Terminal P: <ul style="list-style-type: none">• 5 fixed incremental exercise test protocols (e.g. WHO)• 10 user-programmable protocols• manual load control Control Terminal K: <ul style="list-style-type: none">• 5 fixed incremental exercise test protocols (e.g. WHO)• 10 user-programmable protocols• manual load control• 4 fixed test protocols (e.g. PWC)• 10 user-programmable training protocols
Permitted Patient Weight	max. 160 kg (ergoselect 100 / ergoselect 150 / ergoselect 200) max. 200 kg (ergoselect 200 with stabilizer plate)
Saddle Height Adjustment	continuous, for patients between 120 cm and 210 cm ergoselect 100/150: manual adjustment of saddle height ergoselect 200: electrical adjustment of saddle height with digital readout
Handlebar Adjustment	for patient heights between 120 cm and 210 cm continuous handlebar adjustment over 360° ergoselect 100: rigid steering column ergoselect 150/200: height-adjustable steering column
Crank Length	170 mm (cranks with adjustable length are optional accessories)

Displays	LCD: 68 x 34 mm, 128 x 64 pixels (Control Terminal P) 115 x 88 mm, 320 x 240 pixels (Control Terminal K) additional LED display for speed (RPM)
Interfaces	PORT 1 (DSUB-9-pole): digital remote control RS232 by PC or ECG recorder, remote start of ECG recorder (optional) USB: digital remote control by PC (driver required)
Dimensions, Weight	ergoselect 100/150: length: 900 mm width: 420 mm (width of handlebar: approx. 535 mm) height: 900 mm - 1350 mm weight: approx. 74,5 kg / approx. 80 kg ergoselect 200: length: 900 mm width: 460 mm (width of handlebar: approx. 535 mm) height: 900 mm - 1350 mm weight: approx. 67 kg
Safety Standards	DIN EN 60601-1, DIN EN 60601-1-2, DIN VDE 0750-238
Protection Class / Degree of Protection	II  / B (ergometer) BF (blood pressure module)
MDD Classification	class IIa to 93/42 EEC
RF Emission	class B to DIN EN 55011 / 5.0 DIN EN 60601-1-2
Environment	operation: temperature: +10 to +40 °C (50 to 104 °F) rel. humidity: 30 to 75%, no condensation atmospheric pressure: 800 to 1060 hPa transport and storage: temperature: -20 to +70 °C (-40 to +158 °F) rel. humidity: 10 to 95%, no condensation atmospheric pressure: 500 to 1060 hPa

BLOOD PRESSURE MODULE

Measuring Method:	auscultatory method, oscillometric; for resting BP, the results from both measurements are compared for plausibility
Measuring Range	systolic pressure: 40 to 280 mmHg diastolic pressure: 40 to 280 mmHg pulse rate: 35 to 230 P/min
Measurement Error, systematic	systole: +/- 3 mmHg diastole: +/- 3 mmHg (temperature: +15 ... +25 °C)

Standard deviation (clinical trial)	systole / diastole: 7 mmHg (max.)
Inflation Pressure	300 mmHg max.; during inflation the inflation pressure automatically adapts to patient's BP
Inflation Rate	between approx. 6 seconds (to 140 mmHg) and approx. 18 seconds (to 300 mmHg)
Max. Cuff Pressure	300 mmHg
Cuff Deflation Method	pulse-dependent deflation rate approx. 3 mmHg/beat or approx. 3 mmHg/s
Calibration	calibration with external pressure meter
Artifact Rejection	automatic artifact rejection and comparison of the resting BP readings from both methods for plausibility

EXERCISE TEST PROTOCOLS

Protocol	initial load [W]	time in stage [min]	load increment [W]	recovery load [W]	recovery time [min]
1. WHO	25	2	25	25	99
2. BAL	50	3	50	25	99
3. Hollmann	30	3	40	25	99
4. STD France	30	3	30	25	99
5. Standard	20	1	25	25	99
6. - 15. (user-programmable)	25	2	25	25	99
Adjustment Range	20 - 100	1 - 30	1 - 400	20 - 100 (*)	1 - 99

(*) With Control Terminal P, the recovery load is fixed at 25 W.

TEST PROTOCOLS (CONTROL TERMINAL K ONLY)

Protocol	initial load [W]	duration [sec]	load increment [W]	time in stage [sec]	recovery load [W]	recovery time [min]
ramping protocol	0	120	25	10	25	99
PWC-130 (*)	25	0	25	120	25	99
PWC-150 (*)	50	0	25	120	25	99
PWC-170 (*)	50	0	50	120	25	99

(*) The program advances to the recovery phase as soon as the target heart rate (130/150/170) is reached.

FAMILY OF CHARACTERISTICS OF THE BRAKING TORQUE CONTROL RANGE

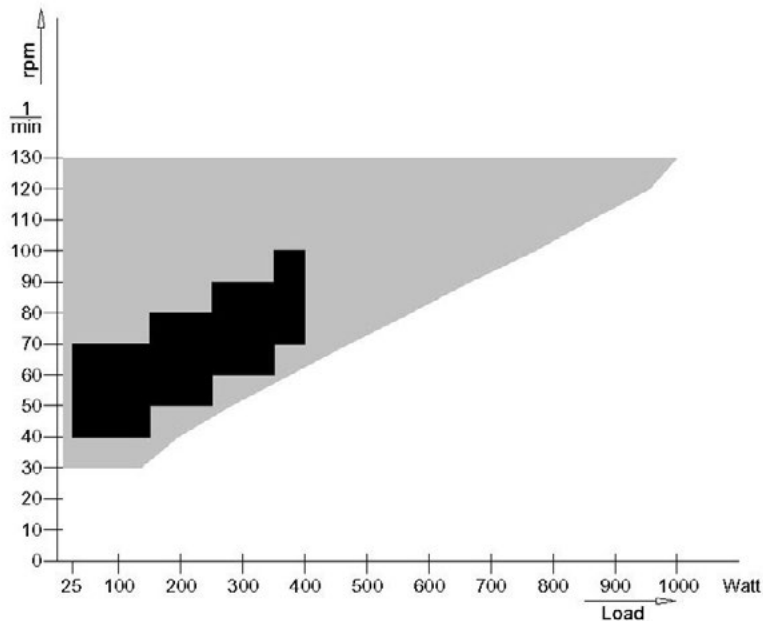

black: speed-independent range to DIN VDE 0750-0238
black + grey: speed-independent range of the ergoselect ergometer

FAMILY OF CHARACTERISTICS OF THE LOAD PERIODS ACCORDING TO IEC 60601-1

Watt	0-20	20-40	40-60	60-80	80-100	100-120	120-140	140-160	160-180	180-200	200-220	220-240
999	14	28	6	40	6	40	6	40	6	40	6	6
900	18	28	7	36	7	36	7	36	7	36	7	7
800	23	28	9	32	9	32	9	32	9	32	9	9
700	29	28	11	29	11	29	11	29	11	29	11	11
600	35	28	14	28	14	28	14	28	14	28	14	14
500	48	28	19	28	19	28	19	28	19	28	19	19
400	72	28	26	28	26	28	26	28	26	28	26	26
350	99	28	38	28	38	28	38	28	38	28	38	38
300	∞											

Under permanent load, the load periods and pauses (white) shall be observed.

ELECTROMAGNETIC COMPATIBILITY

EN 60601-1-2

Changes or modifications to this system not expressly approved by ergoline could cause EMC issues with this or other equipment.

This system is designed to comply with applicable regulations regarding EMC.

Its compliance with these requirements has been verified. It needs to be installed and put into service according to the EMC information stated as follows.

Warning

• RF INTERFERENCE •

- *Use of portable telephones or other radio frequency (RF) emitting equipment near the system may cause unexpected or adverse operation.*

Caution

• Equipment Malfunction •

- *The equipment or system should not be used adjacent to, or stacked with, other equipment. If adjacent or stacked use is necessary, the equipment or system should be tested to verify normal operation in the configuration in which it is being used.*

GUIDANCE AND MANUFACTURER'S DECLARATION – ELECTROMAGNETIC EMISSIONS		
The ergoselect ergometer is intended for use in the electromagnetic environment specified below. It is the responsibility of the customer or user to ensure that the ergoselect ergometer is used in such an environment.		
Emissions Test	Compliance	Electromagnetic Environment – Guidance
RF emissions to EN 55011	Group 1	The ergoselect ergometer uses RF energy only for its internal function. Therefore, its RF emissions are very low and are not likely to cause any interference in nearby electronic equipment.
RF emissions to EN 55011	Class B	The ergoselect ergometer is suitable for use in all establishments, including domestic and those directly connected to the public low-voltage power supply network that supplies buildings used for domestic purposes.
Harmonic emissions to EN 61000-3-2	Class A	
Voltage fluctuations/flicker emissions to EN 61000-3-3	Complies	

GUIDANCE AND MANUFACTURER'S DECLARATION – ELECTROMAGNETIC IMMUNITY

The ergoselect ergometer is intended for use in the electromagnetic environment specified below. It is the responsibility of the customer or user to ensure that the ergoselect ergometer is used in such an environment.

Immunity Test	IEC 60601 Test Level	Compliance Level	Electromagnetic Environment – Guidance
Electrostatic discharge (ESD) to EN 61000-4-2	± 6 kV contact ± 8 kV air	± 6 kV ± 8 kV	Floors should be wood, concrete or ceramic tile. If floors are covered with synthetic material, the relative humidity should be at least 30%.
Electrical fast transient/burst to EN 61000-4-4	± 2 kV for power supply lines ± 1 kV for input and output lines	± 2 kV passed	Mains power should be that of a typical commercial or hospital environment.
Surge to EN 61000-4-5	± 1 kV differential mode ± 2 kV common mode	± 1 kV N/A	Mains power should be that of a typical commercial or hospital environment.
Voltage dips, short interruptions and voltage variations on power supply input lines to EN 61000-4-11	< 5 % UT (> 95 % dip in UT) for 0.5 cycles 40 % UT (60 % dip in UT) for 5 cycles 70 % UT (30 % dip in UT) for 25 cycles < 5 % UT (> 95 % dip in UT) for 5 s	< 5 % UT 40 % UT 70 % UT < 5 % UT	Mains power should be that of a typical commercial or hospital environment. If the user of the ergoselect ergometer requires continued operation during power mains interruptions, it is recommended that the ergoselect ergometer be powered from an uninterruptible power supply or a battery.
Power frequency (50/60 Hz) magnetic field to EN 61000-4-8	3 A/m	passed	Power frequency magnetic fields should be at levels characteristic of a typical location in a typical commercial or hospital environment. The ergoselect ergometer has no components susceptible to magnetic fields.

NOTE: UT is the a.c. mains voltage prior to application of the test level.

GUIDANCE AND MANUFACTURER'S DECLARATION – ELECTROMAGNETIC IMMUNITY

The ergoselect ergometer is intended for use in the electromagnetic environment specified below. It is the responsibility of the customer or user to ensure that the ergoselect ergometer is used in such an environment.

Immunity Test	IEC 60601 Test Level	Compliance Level	Electromagnetic Environment – Guidance
Conducted RF to EN 61000-4-6	3 Vrms 150 kHz to 80 MHz	3 V	<p>Portable and mobile RF communications equipment should be used no closer to any part of the ergoselect ergometer, including cables, than the recommended separation distance calculated from the equation applicable to the frequency of the transmitter.</p> <p>Recommended separation distance: $d = 1.2 \sqrt{P}$ $d = 1.2 \sqrt{P}$ for 80 MHz to 800 MHz $d = 2.3 \sqrt{P}$ for 800 MHz to 2.5 GHz</p> <p>where P is the rated output power rating of the transmitter in watts (W) according to the transmitter manufacturer and d is the recommended separation distance in meters (m).</p> <p>Field strengths from fixed RF transmitters, as determined by an electromagnetic site survey (a), should be less than the compliance level in each frequency range (b).</p> <p>Interference may occur in the vicinity of equipment marked with the following symbol</p> <div style="text-align: center;">  </div>
Radiated RF to EN 61000-4-3	3 V/m 80 MHz to 2.5 GHz	3 V/m	

NOTE 1: At 80 MHz and 800 MHz, the higher frequency range applies.

NOTE 2: These guidelines may not apply in all situations. Electromagnetic propagation is affected by absorption and reflection from structures, objects, and people.

(a) Field strengths from fixed transmitters, such as base stations for radio (cellular/cordless) telephones and land mobile radio, AM and FM radio broadcast and TV broadcast cannot be predicted theoretically with accuracy. To assess the electromagnetic environment due to fixed RF transmitters, an electromagnetic site survey should be considered. If the measured field strength in the location in which the ergoselect ergometer is used exceeds the applicable RF compliance level above, the ergoselect ergometer should be observed to verify normal operation. If abnormal performance is observed, additional measures may be necessary, such as re-orienting or relocating the ergoselect ergometer.

(b) Over the frequency range from 150 kHz to 80 MHz, field strengths should be less than 3 V/m.

**RECOMMENDED SEPARATION DISTANCES BETWEEN PORTABLE AND
MOBILE RF COMMUNICATIONS EQUIPMENT AND THE ERGOSELECT ERGOMETER**

The ergoselect ergometer is intended for use in the electromagnetic environment in which radiated RF disturbances are controlled. The customer or the user of the ergoselect ergometer can help prevent electromagnetic interference by maintaining a minimum distance between portable and mobile RF communications equipment (transmitters) and the ergoselect ergometer as recommended below, according to the maximum output power of the communications equipment.

Rated Maximum Output Power of Transmitter [W]	Separation Distance According to Frequency of Transmitter [m]		
	150 kHz to 80 MHz $d = 1.2 \sqrt{P}$	80 MHz to 800 MHz $d = 1.2 \sqrt{P}$	800 MHz to 2.5 GHz $d = 2.3 \sqrt{P}$
0.01	0.12	0.12	0.23
0.1	0.37	0.37	0.74
1	1.17	1.17	2.33
10	3.7	3.7	7.37
100	11.7	11.7	23.3

For transmitters rated at a maximum output power not listed above, the recommended separation distance d in meters (m) can be estimated using the equation applicable to the frequency of the transmitter, where P is the maximum output power rating of the transmitter in watts (W) according to the transmitter manufacturer.

NOTE 1: At 80 MHz and 800 MHz, the higher frequency range applies.

NOTE 2: These guidelines may not apply in all situations. Electromagnetic propagation is affected by absorption and reflection from structures, objects, and people.

ergoline
MOVING TO HEALTH

ergoline GmbH
Lindenstraße 5
72475 Bitz
Germany

Tel.: +49-(0) 7431 98 94 - 0
Fax: +49-(0) 7431 98 94 - 128
e-mail: info@ergoline.com
http: www.ergoline.com