

CL4416R Probe
Instruction Manual
Specification

MN1-6266 Rev.2

Notes for operators and responsible maintenance personnel

- ★ *Please read through this Instruction Manual as well as the separate Instruction Manual “Safety (MN1-5990)” and “Cleaning, Disinfection and Sterilization (MN1-6161)” carefully prior to use.*
- ★ *Keep this Instruction Manual together with the ultrasound diagnostic instrument for any future reference.*



 **Hitachi, Ltd.**

© Hitachi, Ltd. 2016, 2017. All rights reserved.

Introduction

This is the instruction manual for CL4416R probe. The probe is available by connecting to Hitachi's ultrasound diagnostic instrument and can be used as a transrectal probe for observation of prostate and surrounding organs. It can also be used for ultrasound-guided puncture under the condition that the optional puncture adapter is attached to it. Prior to use, read this manual as well as the separate instruction manual "Safety" in which information for safe use is provided.

The probe bears the CE mark but the mark is valid only when the probe is connected to the ultrasound diagnostic instrument bearing the CE mark.

Symbols used in this document

Safety information is classified into Danger, Warning, Caution, and Note according to the level of hazard. Those terms are used in safety information provided to prevent hazards and injuries to the operator or patient.

Danger

Indicates an imminently hazardous situation which, if not avoided, will result in death or serious injury to the operator or patient.

Warning

Indicates a potentially hazardous situation which, if not avoided, could result in death or serious injury to the operator or patient.

Caution

Indicates a potentially hazardous situation which, if not avoided, may result in minor or moderate injury to the operator or patient, or property damage only.

Note

Indicates a strong request concerning an item that must be observed in order to prevent damage or deterioration of the equipment and also to ensure that it is used efficiently.

The type of safety information is indicated by the symbols below.



This symbol means that attention is required.



This symbol means that the described action is prohibited.



This symbol means that the described action is mandatory.

CONTENTS

1. General Information.....	1
1-1. Intended use.....	1
1-2. Classification of ME equipment.....	1
1-3. Standard components.....	1
1-4. Options.....	2
2-1. Specifications.....	3
2-2. Name of each parts.....	4
3. Preparations before use.....	5
3-1. Visual check.....	5
3-2. Confirmation of cleaning, disinfection, and sterilization.....	5
3-3. Operation check.....	5
4. Operation.....	7
4-1. Operation.....	7
4-2. Relationship between the image and the orientation mark.....	7
4-3. How to mount/remove the probe cover.....	8
4-3-1. How to mount the probe cover.....	8
4-3-2. How to remove the probe cover.....	9
4-4. How to attach/release the magnetic position sensor and the magnetic position sensor attachment.....	9
4-4-1. How to attach the magnetic position sensor and the magnetic position sensor attachment.....	9
4-4-2. How to release the magnetic position sensor and the magnetic position sensor attachment.....	10

This instruction manual contains 4 pages of front matter and 12 pages of the main content.

1. General Information



General information for the probe is provided below.

1-1. Intended use

This probe is intended to be used by a doctor or other qualified operator for ultrasonic observations of the prostate, uterus, and surrounding organs. It can also be used for ultrasound-guided puncture.

Please refer to the ultrasound diagnostic instrument instruction manual used with this probe for the probe intended use information.

Regarding with the connectable instrument, please refer to section 2-1. Specifications of this manual.

 Warning
 Do not use this equipment for other than its intended use. Otherwise it could cause burns or other injuries to the operator or the patient.

1-2. Classification of ME equipment

This probe is classified as follows according to IEC60601-1.

Please refer to the section 2-1 for the applied part, the part treated as the applied part, and the range of IPX7.

- Classification based on the degree of protection against electric shock Type BF applied part
- Classification for protection against ingress of liquids IPX7 (Watertight equipment)
- Operation mode..... Continuous operation
- Method of sterilization..... Refer to the separate instruction manual
“Cleaning, Disinfection and Sterilization”

1-3. Standard components

The standard components of CL4416R probe are as follows.

- CL4416R Probe 1 pc
- Storage case 1 set
- Instruction Manual
 - Specification (MN1-6266) 1 copy
 - Safety (MN1-5990) 1 copy
 - Cleaning, Disinfection and Sterilization (MN1-6161) 1 copy

1-4. Options

The following options are available for CL4416R probe.

- Puncture

Please use one of the options listed in Table 1 for performing a puncture. Regarding the usage of puncture adapter, please refer to the documentation supplied with the puncture adapter.

Table 1 Options for puncture

Product Name	Product No.	Remark
Puncture Guide Fixture	BA-001	Applicable needle size: 16G, 18G, 20G

- Probe cover

Please use the option listed in Table 2 for probe cover. Please refer to the section 4-3 for how to mount/remove the probe cover.

Table 2 Option for probe cover

Product Name	Product No.
Rubber Boot	RB-945BP-NS

- Real Time Virtual Sonography (RVS)

Please use the option listed in Table 3 for performing RVS. Please refer to the section 4-4.

Table 3 Option for RVS

Product Name	Product No.
Magnetic Sensor Attachment	RV-011

- Reprocessing by liquid detergent, disinfectant or sterilant

Whole the probe is able to immerse into the liquids by putting the connector of the ultrasound probe to the waterproof case WP-001 as below table 4.

Precautions about the waterproof case, please refer to the instruction manual.

Table 4 Accessory for reprocessing by liquid detergent, disinfectant or sterilant

Product Name	Product No.
Waterproof case	WP-001

2. Specifications and Parts name

The specifications and the name of each part are provided below.

2-1. Specifications

Application:	Urological applications
Type of patient contact:	Transrectum, Transvaginal
Connectable instruments:	ARIETTA 70, ARIETTA 60, ALOKA ARIETTA 850
	NOTE:
	At the time of publication of this manual, the connectable diagnostic ultrasound instrument or instrument software version available with this probe is different for each country, please refer to the instrument instruction manual or contact your local Hitachi representative.
Field of view:	63mm (Sagittal plane), 180° (Axial plane)
Frequency:	7.5 MHz (Sagittal plane), 6.5 MHz (Axial plane)
Cable length:	2.5 m
Service life:	3 years
Applied part:	See Figure 1
Part treated as Applied part:	See Figure 1
IPX7 range:	See Figure 1 (In case that not putting the waterproof case to the ultrasound probe connector) In case that putting the waterproof case to the ultrasound probe connector, whole the probe from the tip of the ultrasound probe to the connector with Waterproof Case WP-001 is IPX7. range
Measurement accuracy:	Refer to the instruction manual of the ultrasound diagnostic instrument
External dimensions:	See Figure 1

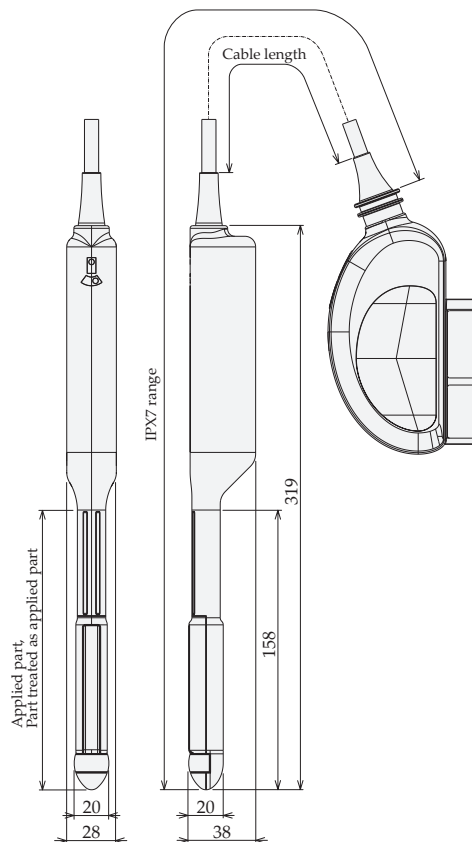

Unit: mm

Remark: The tolerance for the dimensions is $\pm 10\%$.

Figure 1 External View

2-2. Name of each parts

The name of each part is shown in Figure 2 and the explanation for each part is listed in Table 5.

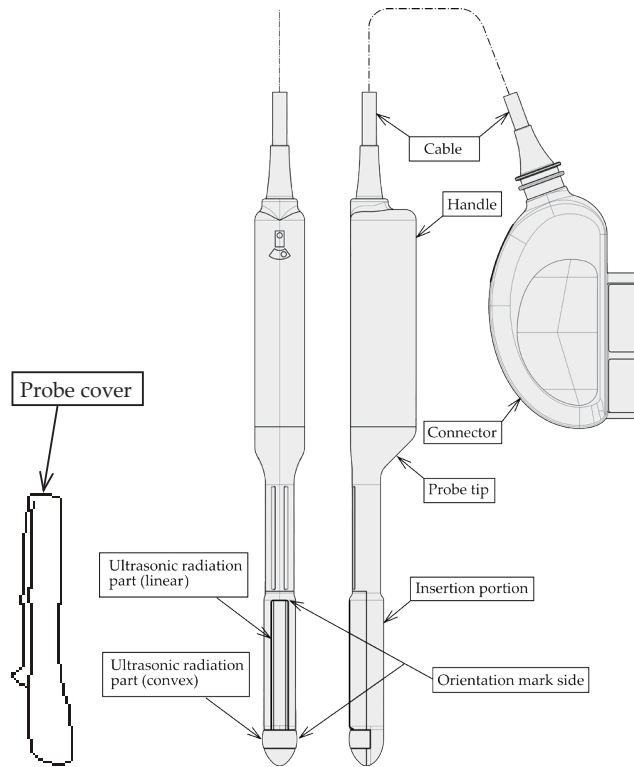

Figure 2 Name of each parts

Table 5 Name of each part and its explanation

Name	Explanation
Ultrasonic radiation part (convex)	Ultrasound is radiated from this part. The electronic convex transducer is integrated underneath this part.
Ultrasonic radiation part (linear)	Ultrasound is radiated from this part. The electronic linear transducer is integrated underneath this part.
Orientation mark side	The side of the orientation mark corresponds to the side of the orientation mark on the image. See 4-2.
Probe tip	The probe tip is the part includes both the insertion portion and the handle.
Handle	This part is held during operation.
Insertion portion	This part is inserted into the patient.
Cable	Cable transfers electric input/output signals.
Connector	The connector is the part which is connected to the ultrasound diagnostic instrument.
Probe cover	This covers the insertion portion for preventing infection. Follow the instructions in section 4-3.

⚠ Caution	
⊘	Do not pull, bend, twist, or apply excessive force to the cable. The probe may malfunction due to cable disconnection.
⊘	Do not subject the ultrasonic radiation part to hard impact. The impact may cause damage to the transducer, and that results in noise or no echo in the image. In most cases, the ultrasonic radiation part itself is not damaged because the part is made of elastic material.

3. Preparations before use

This chapter describes preparations needed to use the probe safely. Please prepare the probe prior to each use by following the instructions below.

3-1. Visual check

Visually check the ultrasonic radiation part, insertion portion, handle, cable, and connector.

If any holes, indentations, abrasion, cracks, deformation, looseness, discoloration, or other abnormalities are found, do not use the probe.

Check also the options as necessary.

3-2. Confirmation of cleaning, disinfection, and sterilization

Confirm that the probe is certainly cleaned, disinfected, and sterilized. The degree of reprocessing depends on the intended use. Please refer to the separate instruction manual “Cleaning, Disinfection and Sterilization“ for cleaning, disinfection, and sterilization procedure. Confirm also that options are properly cleaned, disinfected, and sterilized.

3-3. Operation check

Connect the probe to the ultrasound diagnostic instrument and check that the displayed scan type and frequency correspond to those of the probe. Check also that there is no abnormality in the image.

Remark: Please refer to the documentation supplied with the ultrasound diagnostic instrument for how to connect the probe and information displayed on the monitor.

If the probe is operated in still air, brightness on the top of the image may be non uniform, but this does not affect the performance of the probe.

Warning

Make preparations prior to each use.



The operator and the patient may be injured if the equipment has any abnormality.

If any abnormality is found in the equipment, stop using it and contact our office written on the back cover.

Caution

Do not use the probe if the displayed scan type and frequency do not correspond to those of the probe.



Incorrect acoustic output can result in burns or other injuries to the patient. Contact our office written on the back cover.

4. Operation

This chapter describes the operation of the probe, the image direction, and how to attach magnetic position sensor and Magnetic Position Sensor Attachment.

4-1. Operation

Mount a probe cover on the probe and insert the probe into the body cavity. An image of the region of interest is displayed on the monitor of the ultrasound diagnostic instrument. For details on displaying and adjusting the image, refer to the documentation supplied with the ultrasound diagnostic instrument.

⚠ Caution	
⊘	Do not operate the probe with excessive force. Use with excessive force could result in injury to the patient.
!	Scan for minimum time necessary at the lowest possible acoustic output. Acoustic output may affect the patient's internal tissues. For details about the acoustic output, please refer to the documentation supplied with the ultrasound diagnostic instrument.
⊘	Do not touch the connector terminal pin of the probe. Electrostatic discharge may result in malfunction of the probe.
⊘	Do not touch the probe connector of the ultrasound diagnostic instrument and the patient at the same time. It can cause electric shock to the patient.

4-2. Relationship between the image and the orientation mark

This probe has two ultrasound radiation parts, one for Sagittal image and the other for axial image. Figure 3 shows the relationship between the direction of the probe and the orientation mark in the image.

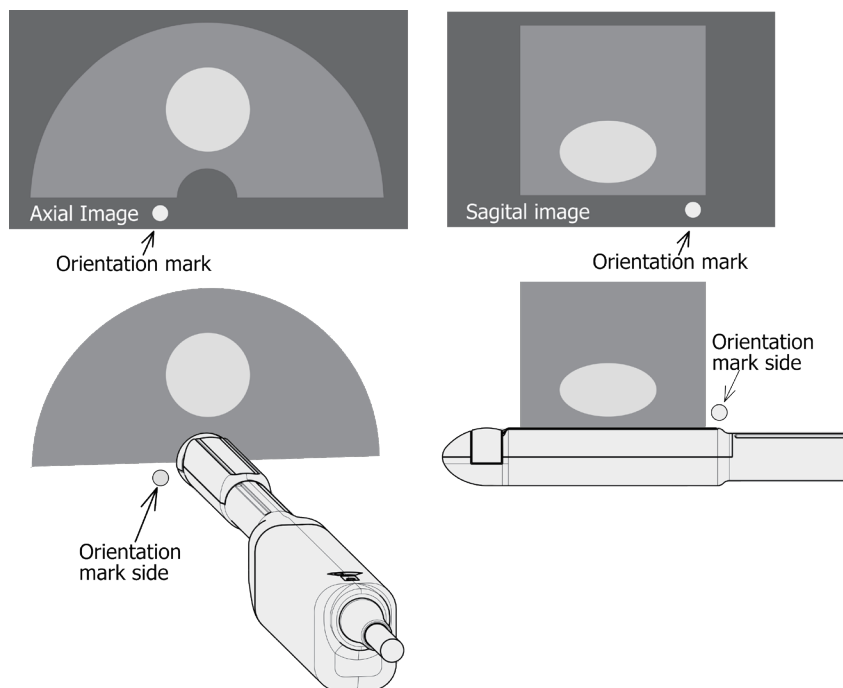

Figure 3 Relationship between the direction of the probe and the orientation mark

4-3. How to mount/remove the probe cover

4-3-1. How to mount the probe cover

Apply a suitable amount of ultrasound gel on the ultrasound radiation part and then mount the probe cover on the probe.

Remove air bubbles in the ultrasound gel or wrinkles of the probe cover on the ultrasound radiation part.

apply a suitable amount of ultrasound gel

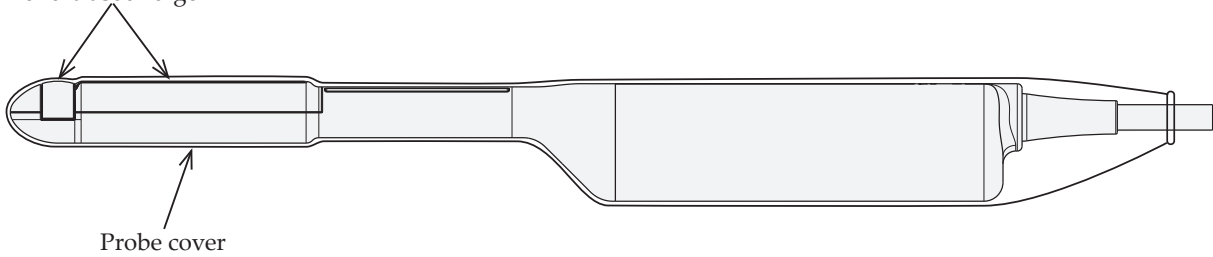

Figure 4 How to mount the probe cover

⚠ Warning	
!	Mount the probe cover on the insertion portion. If the probe cover is not mounted, residual pathogens on the probe could infect the patient.
!	Use Hitachi-approved probe covers only. Use of non biocompatible probe covers can cause an adverse reaction.
!	Use only sterile probe covers. Use of non sterile probe covers could cause infection to the patient.
⊘	Do not reuse the probe cover. Reuse of probe covers may cause infection to the patient.
⊘	Do not apply non sterile acoustic medium on the probe cover. Use of non sterile acoustic medium can cause infection to the patient.
⊘	Do not use latex probe covers for patient who may have an allergic reaction. Use of the latex probe covers could result in anaphylactic shock. Ask the patient about allergy history before diagnosis.

⚠ Caution	
!	Confirm the storage condition and the expiration date of the probe cover. Store the probe cover according to its instruction. Do not use the probe cover if the expiration date has passed, if it is discolored or if there is visible damage such as a tear.
!	Confirm that there is no air bubbles in the ultrasound gel on the ultrasound radiation part. Air bubbles on the ultrasound radiation part can result in misdiagnosis due to poor image quality or improper rendering.

4-3-2. How to remove the probe cover

- (1) Wrap the probe cover in tissue and remove the probe cover from the probe.
- (2) Dispose tissue and the probe cover according to the infection prevention procedures of your facility.

⚠ Caution
<p>! Before disposing of the equipment, disinfect or take other infection-prevention measures. Disposal of the equipment without taking the proper preventative measures can lead to infection.</p>

4-4. How to attach/release the magnetic position sensor and the magnetic position sensor attachment

This section provides how to attach the magnetic position sensor and the magnetic position sensor attachment to the probe.

4-4-1. How to attach the magnetic position sensor and the magnetic position sensor attachment

- (1) Confirm that the magnetic position sensor attachment is sterilized or disinfected.
- (2) Insert the magnetic position sensor into the magnetic position sensor attachment with the correct direction as shown in Figure 5.
- (3) Attach the magnetic position sensor attachment to the probe as shown in Figure 6.

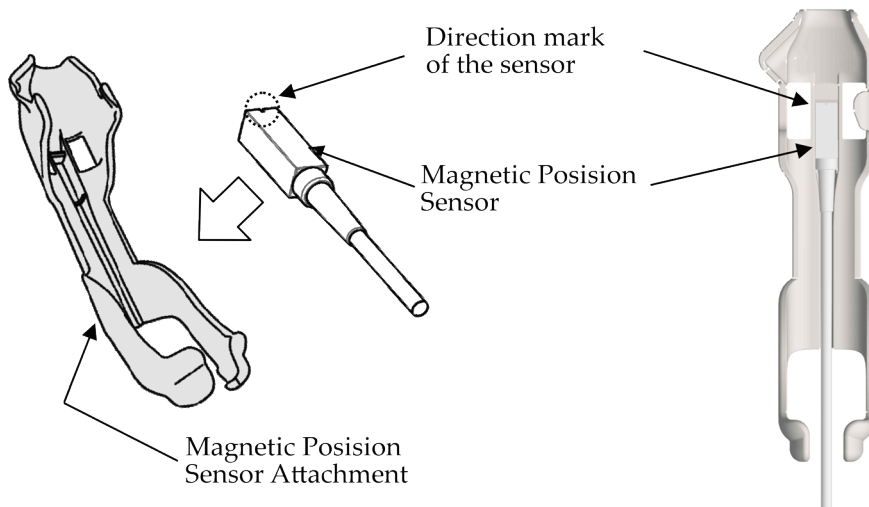

Figure 5 How to attach Magnetic Position Sensor

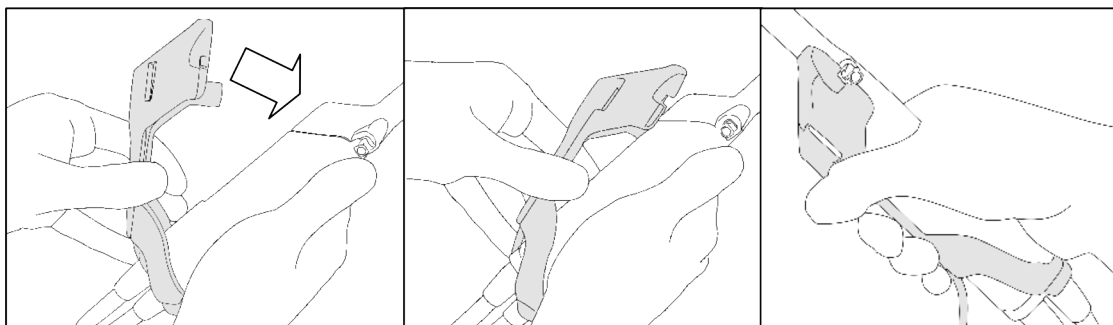

Figure 6 How to attach Magnetic Position Sensor Attachment

⚠ Caution	
!	Never attach the magnetic position sensor attachment to the probe in the incorrect direction, otherwise it may result in false diagnosis.
!	Be careful not to put your fingers between the magnetic position sensor attachment and the probe when attaching the attachment to the probe.
⊘	Do not use the magnetic position sensor attachment if it fell on the floor, otherwise there is a risk of infection. Stop using it and perform the reprocessing procedure described in the separate instruction manual "Cleaning, Disinfection and Sterilization" and make preparations before use described in this manual.

4-4-2. How to release the magnetic position sensor and the magnetic position sensor attachment

- (1) Release the magnetic position sensor attachment from the probe as shown in Figure 7.
- (2) Release the magnetic position sensor from the magnetic position sensor attachment as shown in Figure 8.

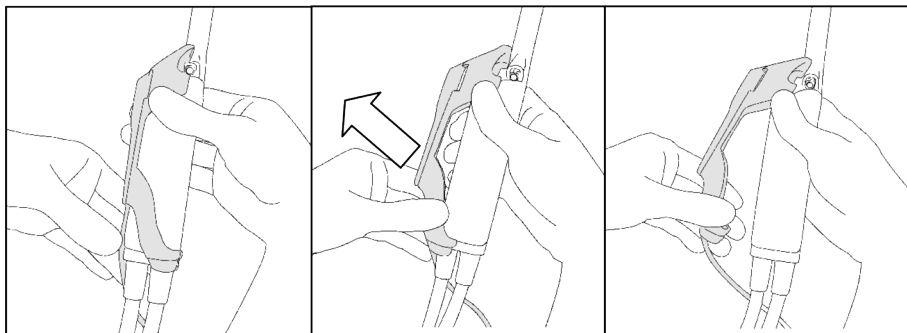

Figure 7 How to release Magnetic Position Sensor Attachment

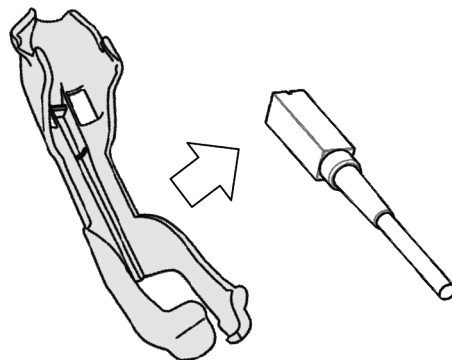

Figure 8 How to release Magnetic Position Sensor from the attachment

■ Manufacturer

 Hitachi, Ltd.

2-16-1, Higashi-Ueno, Taito-ku, Tokyo, 110-0015, Japan

■ Contact

+81-3-6284-3668

<http://www.hitachi.com/businesses/healthcare/index.html>

Overseas Offices:

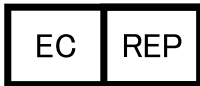

Hitachi Medical Systems GmbH

Otto-von-Guericke-Ring 3 D-65205 Wiesbaden, Germany

EU Importer: Hitachi Medical Systems Europe Holding AG

Address: Sumpfstrasse 13 CH-6300 Zug, Switzerland

US Importer: Hitachi Healthcare Americas Corporation

Address: 1959 Summit Commerce Park, Twinsburg, Ohio 44087

Distributor