

C42K Probe

INSTRUCTION MANUAL

Notes for operators and responsible maintenance personnel

- ★ Please read through this Instruction Manual carefully prior to use.
- ★ Keep this Instruction Manual together with the system with care to make it available anytime.

 **Hitachi, Ltd.**
Tokyo, Japan

Q1E-EP1391-6

© Hitachi, Ltd. 2013,2017. All rights reserved.

Manufacturer:



Hitachi, Ltd.

2-16-1, Higashi-Ueno, Taito-ku, Tokyo, 110-0015,
Japan

+81-3-6284-3668

[http://www.hitachi.com/businesses/healthcare/
index.html](http://www.hitachi.com/businesses/healthcare/index.html)

European

Representative:



Hitachi Medical Systems GmbH

Otto-von-Guericke-Ring 3 D-65205 Wiesbaden,
Germany

EU Importer:

Address:

Hitachi Medical Systems Europe Holding AG

Sumpfstrasse 13 CH-6300 Zug, Switzerland

Local Distributor:

About this manual

This instruction manual shall provide instructions for using, cleaning, and disinfecting and/or sterilizing the HITACHI ultrasound probes. It also describes safety considerations, maintenance.

For instructions for operating the main unit, refer to the operation manual for it.

Before using the probe, thoroughly read this manual and keep this book for future reference.

If you have any questions concerning the manual, please contact a service support.



The following conventions are used throughout the manual to denote information of special emphasis.

WARNING: "Warning" is used to indicate the presence of a hazard which can cause severe personal injury, death, or substantial property damage if the warning is ignored.

CAUTION: "Caution" is used to indicate the presence of a hazard which will or can cause minor personal injury or property damage if the caution is ignored.





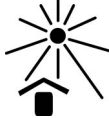



NOTICE: "Notice" is used to notify people of installation, operation, or maintenance information which is important, but not hazard related.

Graphical Symbols for Use in Labeling of Hitachi Ultrasound Probes
 Some graphical symbols that are used in labeling of Hitachi Ultrasound Probes are compliant with EN980:2008 standard. Refer to the following table about the meanings of them.

Explanation of Symbol	Symbol	Descriptive Content
Manufacturer Company Name and Address		Hitachi, Ltd. 2-16-1, Higashi-Ueno, Taito-ku, Tokyo, 110-0015, Japan +81-3-6284-3668 http://www.hitachi.com/businesses/healthcare/index.html
Authorized Representative in The European Community		Hitachi Medical Systems GmbH Otto-von-Guericke-Ring 3 D-65205 Wiesbaden, Germany
Keep away from Sunlight		Store the probe in a cool place and keep away from high temperature, high humidity, or direct sunlight.

Definition of symbol

The following symbol is also used for HITACHI Ultrasound Probes.

Location	Symbol	Definition
Probe connector		This instrument complies with Directive 93/42/EEC relating to Medical Device and Directive 2011/65/EU relating to RoHS
Probe connector		IPX7 mark See section 1.6.
Probe connector		Type BF APPLIED PART
Probe connector		General warning sign
Probe connector		Warning; dangerous voltage
Probe connector		Caution; Biohazard
Probe connector		Follow the instruction manual to operate this instrument. If not avoided, may result in injury, property damage, or the equipment trouble.
Probe connector		STERRAD sterilization compatibility mark
Probe connector		Do not waste the instrument as general waste. Comply with a local regulation.
Probe connector	Rx Only	By prescription only. U.S. Federal Law restricts this device to sale on order of a physician only.

CONTENTS

	Page
1. General	1
1.1 General	1
1.2 Principles of operation	1
1.3 Intended Use	1
1.4 Components	2
1.5 Option	2
1.5.1 Puncture adapter (MP-2458)	2
1.5.2 Puncture adapter (MP-2783)	2
1.5.3 CIVCO Bracket (CIV-614-068)	2
1.6 External View	3
2. Inspection before Use	4
2.1 Inspection for Appropriate Connection	4
2.2 Inspection for Material Surface	4
3. Operation Procedure	5
4. Cleaning, Disinfection and Sterilization	7
4.1 Point of use (Pre-cleaning)	8
4.2 Containment and transportation	8
4.3 Manual Cleaning and disinfection	9
4.4 Drying	10
4.5 Inspection	10
4.6 Packaging	11
4.7 Sterilization	12
4.8 Storage	14
5. Maintenance and Safety Inspection	14
6. Safety Precautions	15
7. Specifications	16
7.1 Probe	16
7.2 Suppliers List	17
8. Disposal of the probe	17

1. General

1.1 General

C42K Probe is a Convex Array Probe.

The acoustic output of this probe when connected to ultrasound scanner was measured according to IEC 60601-2-37 standard.

The table of measured acoustic output data is contained in the operation manual of each ultrasound scanner.

This probe is categorized in class IIa according to Directive 93/42/EEC. According to IEC 60601-1 the probe is classified as type BF.

1.2 Principles of operation

This probe and the ultrasound diagnostic scanner enable image diagnosis using ultrasonic waves. This system operates under the principles described below.

- 1) When an electric pulse signal is applied from the transmitter to the transducer of the probe, the transducer converts electric signals into mechanical vibration energy for emitting pulse-shaped ultrasonic waves into the body part, liquid or other medium contacting the transducer.
- 2) The emitted ultrasonic waves are reflected by boundaries with different acoustic characteristics (acoustic impedance) within the body.
- 3) The transducer is also used to receive reflected ultrasonic waves. The transducer vibrates mechanically due to the received ultrasonic waves and converts mechanical vibrations into electric energy. Electric signals are converted to shades of brightness by brightness modulation to obtain an image.

⚠ WARNING

- 1) Never use the probe for following applications.
 - Direct contact to the heart.
 - Biopsy to the heart.
 - Direct contact to the eye
- 2) Never use the probe with (HF) surgical equipment.

1.3 Intended Use

C42K Probe is designed for observation and diagnosis mainly of the following regions by connecting with the HITACHI ultrasound scanner.

- Intraoperative

1.4 Components

The components of C42K Probe are given below:

- 1) Probe 1 piece
- 2) Instruction manual 1 copy

CAUTION

Sterilization has not been made to the probe, shipped from the factory. Prior to use of the probe, be sure to clean, disinfect and sterilize the probe.

1.5 Option

1.5.1 Puncture adapter (MP-2458)

- 1) Puncture adapter (MP-2458-MB) 1 set
- 2) Needle stopper (MP-2477) 1 set
- 3) Depth gauge (MP-2458-DG) 1 piece
- 4) Adjustment hexagon screwdriver 1 piece
- 5) Instruction manual 1 copy

1.5.2 Puncture adapter (MP-2783)

- 1) Puncture adapter unit (MP-2783-MB) 1 set
- 2) Probe holder (MP-2783-PH) 1 piece
- 3) Needle guide (MP-2783-G20)
(For 20G puncture needle) 1 piece
- 4) Instruction manual 1 copy

1.5.3 CIVCO Bracket (CIV-614-068)

Please refer to the instruction manual of option about the method of handling, cleaning, disinfection and sterilization.

CAUTION

- 1) Sterilization has not been made to the MP-2458 and MP-2783 shipped from the factory. Prior to use of them, be sure to clean, disinfect and sterilize them.
- 2) A biopsy should be performed only by a well-trained physician. Use only the authorized puncture adapter for performing a biopsy.

1.6 External View

The external view of C42K Probe is shown in Fig. 1.

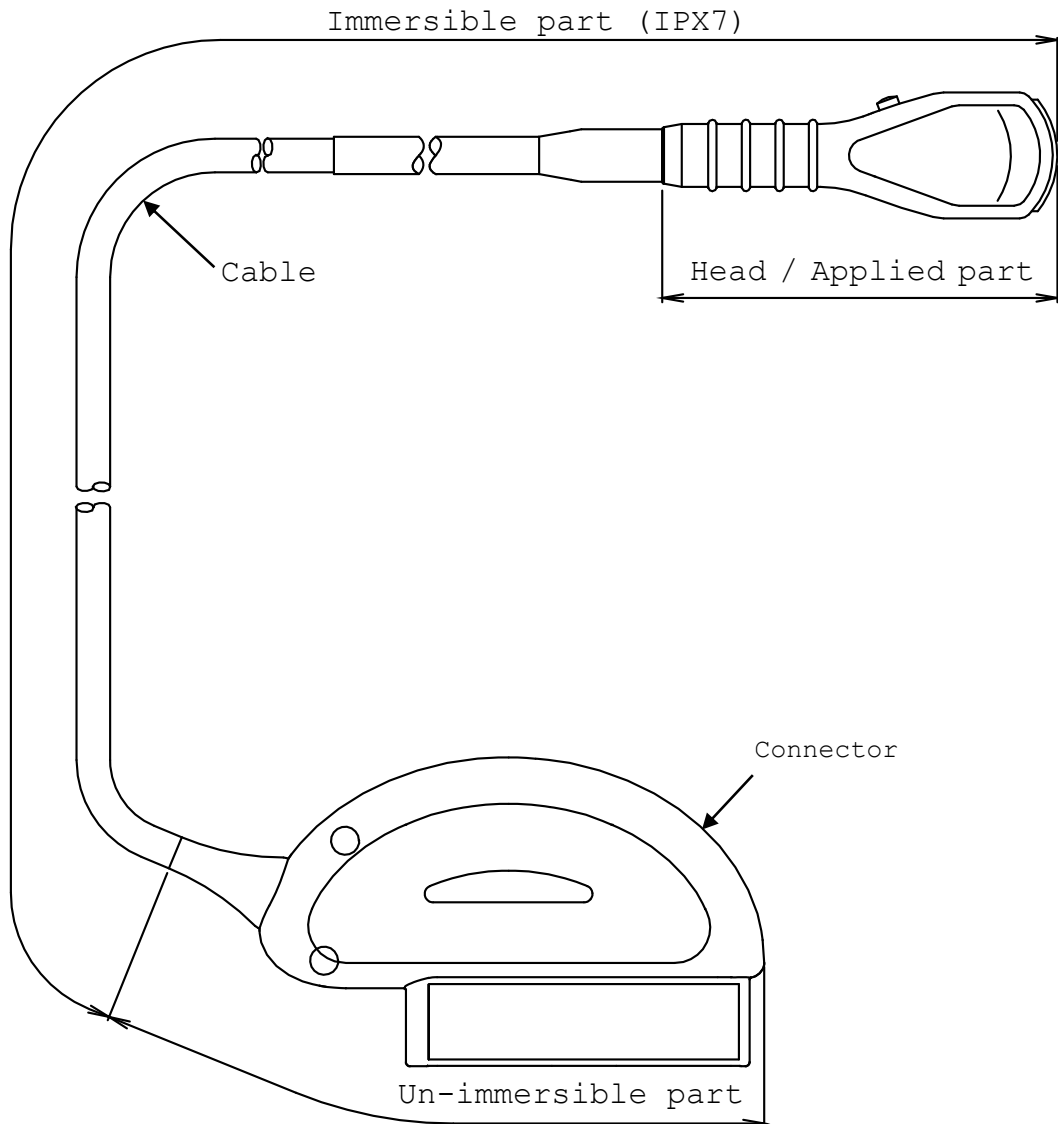

Immersible part:

This part can be immersed in disinfectant solution and also can be cleaned by water.

Un-immersible part:

This part should not be immersed in disinfectant solution and also cannot be cleaned by water.

Fig. 1 External View

2. Inspection before Use

Prior to use, the probe must be carefully inspected that they are appropriate for use.

2.1 Inspection for Appropriate Connection

- 1) Confirm that the system is correctly operating. Refer to the instruction manual for the ultrasound diagnostic scanner.
- 2) Do not attach or connect unauthorized devices or instruments on the probe, such as unauthorized biopsy attachments.

2.2 Inspection for Material Surface

Visually inspect the surface of the probe head, housing, the cable and the connector for any crack, scratch or denaturalization. If you find any damage, do not use the probe, and immediately contact a service support.

3. Operation Procedure

- 1) Confirm that the probe is disinfected or sterilized.
- 2) It is recommended to use a disposable probe cover for preventing a patient from infection.
- 3) Connect the probe to the ultrasound diagnostic scanner, operate the scanner, and adjust the image, all according to the instructions given in the operation manual for the ultrasound diagnostic scanner with which the probe is used as connected.
- 4) Confirm the direction of the probe. The relationship between the direction of the probe and image is shown in Fig. 2. The Right-left orientation mark on the image indicates the direction of the index mark of the probe.

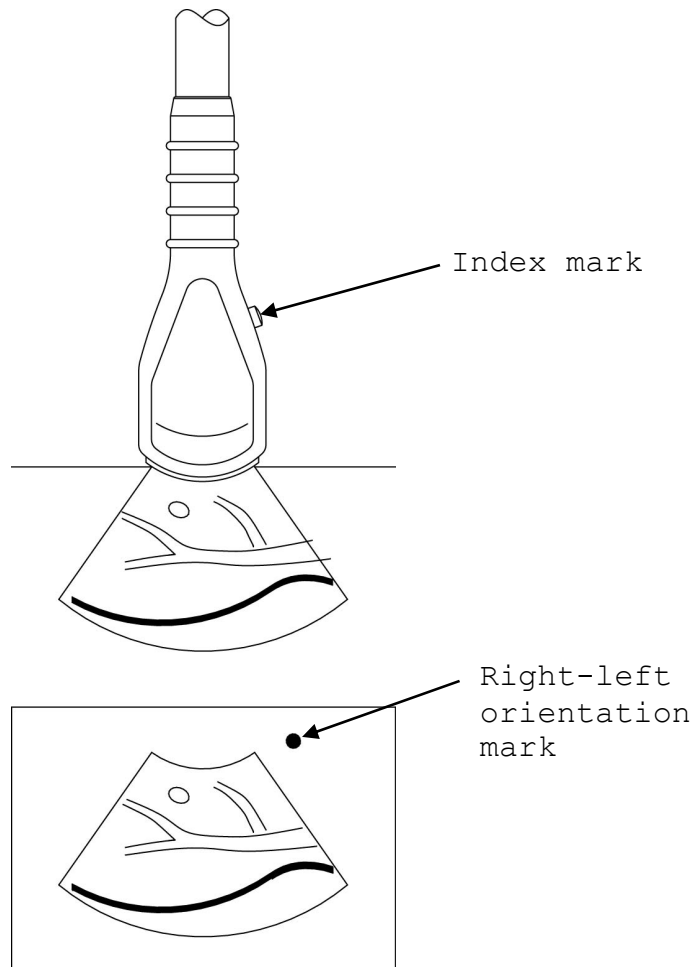

Fig. 2 Relationship between the directions of the probe and the Right-left orientation mark

- 5) Use under sterile condition, protect the probe by using covers (Refer to Suppliers List). Some Latex material may create allergic reaction. Please use allergy free material covers.
- 6) After using the probe, perform the reprocessing procedure in accordance with the procedure stated in "4. Reprocessing Procedure" every time immediately after completing the ultrasound examination.

7) Store the probe in the environment indicated in "5. Maintenance and Safety Inspection".

 **CAUTION**

The acoustic lens of the probe is very thin and delicate. So if the surface of the acoustic lens is wiped for removing remaining ultrasound jelly or cleaned, use the soft cloth or tissue paper and handle with care.

4. Cleaning, Disinfection and Sterilization



The probe and accessory must be reprocessed after each use. Refer to the reprocessing instruction in this chapter.

WARNINGS	<ul style="list-style-type: none"> - The probe is delivered unsterile. Prior to the first use, reprocess the probe. - Temperature should not exceed 60°C during reprocessing. - Probe connector is not water resistant.
Limitations on reprocessing	The probe is not completely submersible. The immersible part is shown in Fig.1. The un-immersible part should be disinfected by wipe disinfection.
Transportation before using	The probe should be packed in a sterile pouch or container to transport from Central Sterile Supply Department (CSSD) to an operating room. Be careful not to damage the sterile pouch or container during transportation.

Levels of reprocessing requirements:

Depending on the application of the product and with regard to risk evaluation, the user has to classify the medical device according to the current Medical Device Directive for processing of medical devices as uncritical, semi-critical or critical. Supporting information concerning this topic is listed in the table below. The user is responsible for correct classification of the medical device.

Classification	Definition	Processing
uncritical	Application part only contacts intact and uninjured skin	Cleaning Disinfection
semicritical	Application part contacts mucosa (intracavitary application)	Cleaning Disinfection (Disinfectant with virucidal effect)
critical	Application part contacts intracorporeal tissue directly (operative application)	Cleaning Disinfection (Disinfectant with virucidal effect - minimum) Sterilization

According to the intended use, C42K probe is classified as critical.

The flowchart of the reprocessing process of this probe is as follows.

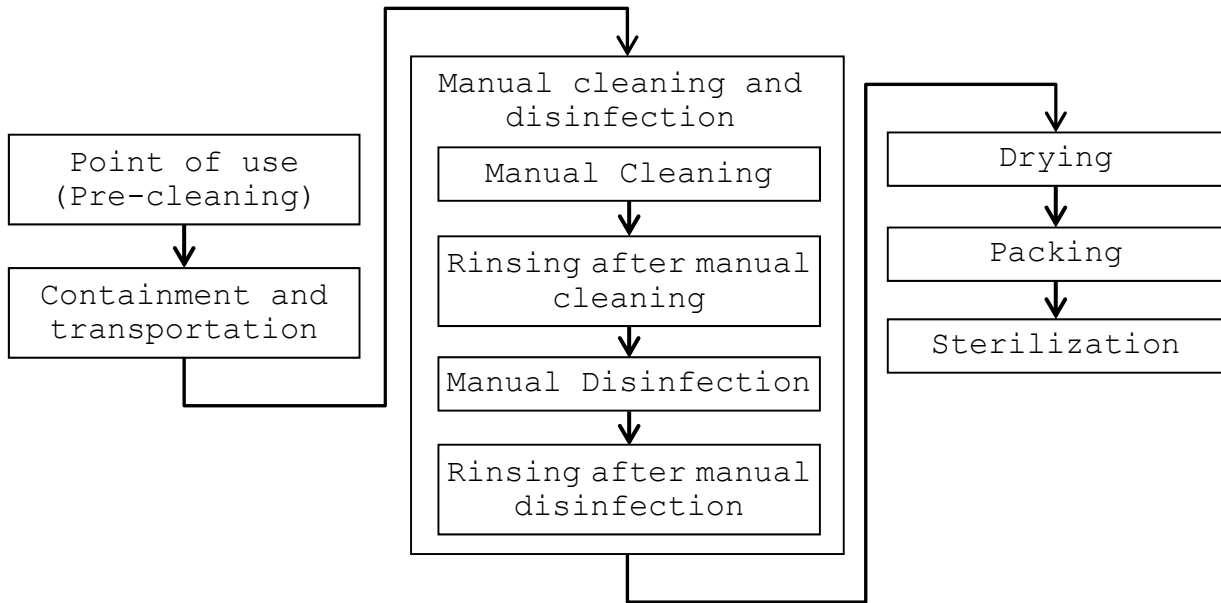

4.1 Point of use (Pre-cleaning)

Pre-cleaning should be done immediately after each use. The procedure is as follows:

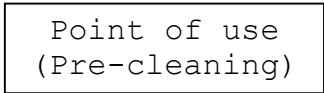

- 1) Remove the protective cover.
- 2) Clean the probe of all patient's blood or fluid with running tap water until the surface of the probe looks visually clean.
- 3) Wipe the whole surface of the probe with gauze pad and remove superficial visible impurities.

4.2 Containment and transportation

Putting the contaminated equipment into exclusive shock and damage proof container for transportation is recommended. It is recommended that instruments are reprocessed as soon as possible and not later than 4 hours after usage.

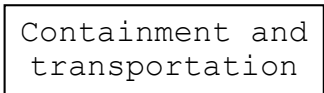

4.3 Manual Cleaning and disinfection

Prepare following items before manual cleaning and disinfection:

- a) Detergent: Cidezyme® (Johnson & Johnson, #2258) or another cleaning agent with approved material compatibility for this medical device
- b) Disinfectant: Cidex® OPA (Johnson & Johnson, # 20391) or another disinfectant with approved material compatibility for this medical device
- c) Two tanks, one for cleaning and one for disinfection - optional:
1 additional tank for rinsing with deionized/tap water (sufficient size for immersion of the immersible part of the probe at full length)
- d) Soft, fluff free cloth or single use towel
- e) Personal protective equipment (gloves, water repellent protective skirt, face protection mask or protective glasses, see also instructions of the manufacturer for the detergent and the disinfectant)

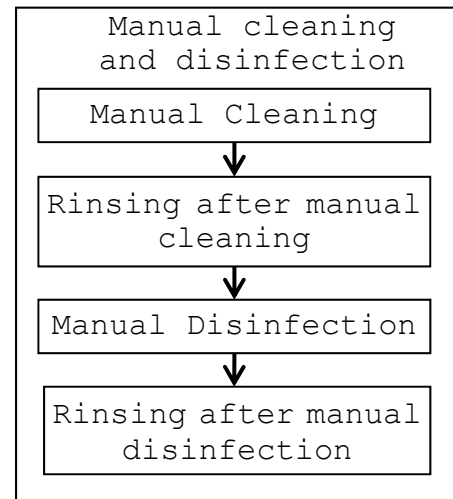

Manual Cleaning:

Prepare the detergent solution in a tank with cold water (please follow the instructions of the detergent manufacturer regarding application, dilution and contact time).

- 1) The temperature of the detergent solution should be between 15-30°C, concentration is 1.6%. Please note the minimum contact time of the detergent in the manufacturer's instruction. If a differing detergent is used, please also note the approved material compatibility for the medical device.
- 2) Immerse the immersible part of the probe without connector into the diluted detergent solution (see Figure 3). Wipe the immersible part of the probe under the surface of the detergent solution with a soft cloth to remove all visible soil. Be sure that all grooves of the probe are implemented during the cleaning process.
- 3) The immersible part of the probe should be left in the detergent solution according to the specified contact time of the detergent manufacturer.
- 4) Wipe the un-immersible parts of the probe with a soft cloth dipped with the detergent solution.
- 5) Rinse the probe with running tap water for 1 minute. (alternatively: immerse the immersible part of the probe in a tray filled with deionized water/tap water (see Fig.3) for 5 min.)
- 6) Visually check the outer surface of the probe for cleanness. If necessary, use magnifying glass for visually check. If there is still soil visible, repeat all above steps.

Manual disinfection:

- 1) Prepare the disinfectant solution in a tank with cold water (please follow the instructions of the disinfectant manufacturer regarding application, concentration, microbiological efficiency, service life and contact time).
- 2) Confirm the concentration of the disinfectant before immersing the probe. Although Cidex® OPA does not need to be diluted, it is recommended to use test strips to verify the concentration. The test strips can indicate whether or not the concentration is above the Minimum Effective Concentration (MEC). Please also note the expiration date of the test stripes. Temperature of disinfectant solution should be minimum 20°C. The minimum contact time is 5 minutes. If a different disinfectant is used, follow the manufacturer's instructions. Please also consider the material compatibility for the medical device.

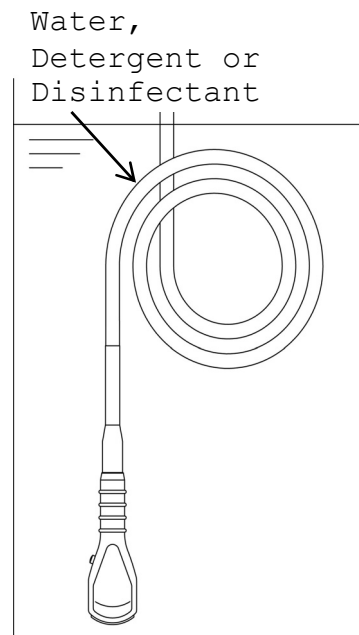

Fig. 3 Immersion of the probe

- 3) Immerse the immersible part of the probe into the disinfectant (see Fig. 3). Set a clock to insure the recommended contact time which is 5 minutes.
- 4) Rinse the immersible part of the probe with deionized water for 1 minute. (alternatively: immerse the immersible part of the probe in a tray filled with deionized water (see Fig. 3) for 5 min.)
- 5) Visually check the outer surface of the probe for leavings of the disinfectant. If necessary, repeat the rinsing.

4.4 Drying

Drying

- 1) Wipe the equipment with a single-use, fluff-free wipe or towel to remove moisture from the surface of the equipment.
- 2) Dry the equipment naturally in an ambient temperature between 15-30°C for a minimum of 4 hours. Alternatively the equipment can be dried using a drying heater at a temperature of less than 60°C.

4.5 Inspection

Inspect the equipment for any damage such as crack, scratch or deformation. Do not use it if any damage is found.

4.6 Packaging

Pack the equipment in a sterile barrier such as Polypropylene fleece or transparent package made from Polyethylene film and Tyvek®, and then place it into a tray. The tray should be also covered with a sterile barrier.

Additionally the equipment can be placed on plastic mesh wires supplied for plasma sterilization and then packed as mentioned above.

The equipment can be packed in a simple or double packing.

Please note that the size of a sterile barrier should be large enough to be able to pack the equipment leaving sufficient space to seal it completely.

A sterile barrier should be sealed by an appropriate sealing machine and it is important to confirm that the package is sealed completely. If the sealing is not complete, pack and reseal again.

4.7 Sterilization

Sterilization

The probe and accessory can be sterilized using either ethylen oxide gas (EtO) sterilization or plasma sterilization (see table below).

Follow the manufacturer's instructions of the sterilizer regarding usage, temperature and sterilization-time.

The sterilization method and operating conditions are as follows.

➤ ETO Gas Sterilizer, closed system

Parameter	Specification
Preconditioning	None
Conditioning in Chamber (Dwell)	Temperature: 122.0 - 131.0 °F (equivalent of 50 - 55 °C) Humidity: 40 - 90 % RH Prevacuum: 8 - 26 kPa Time: 30 - 45 minutes
Exposure	Temperature: 122.0 - 131.0 °F (equivalent of 50 - 55 °C) Sterilant gas: 10 % EO / 90 % HCFC Excess pressure: 162 - 200 kPa Exposure time: 120 - 125 min (full cycle)
Post-vacuum	8 - 26 kPa, 2 times
Aeration	Temperature: 50 - 55 °C Time: min. 11 hours

➤ Plasma sterilization

Sterilization Method	Condition
Plasma Sterilization: STERRAD® 50, 100S or 200 (*)	Short Cycle
Plasma Sterilization: Sterrad® NX or 100NX (*)	Standard cycle

* STERRAD® systems are manufactured by "Johnson & Johnson"

⚠ WARNING ⚠

- 1) Before performing sterilization, check that the operation data of sterilizer are in conjunction with min. and max. data applicable for the probe and the Magnetic sensor attachment.
- 2) Do not sterilize the probe and the Magnetic sensor attachment by Steam Autoclaving. If you autoclave them, they suffers serious damage and will be not functional.

The packaging before sterilization is as follows.

- 1) Put the probe into TYVEK pouch.

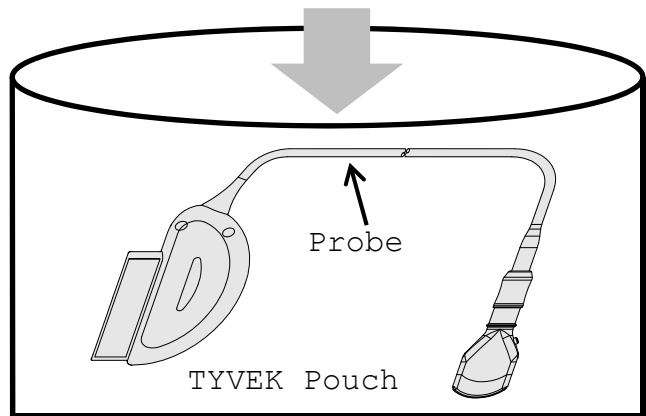

Fig. 4 Packaging in the pouch

- 2) Seal the TYVEK Pouch using a heat sealer. Ensure that the seal is complete.

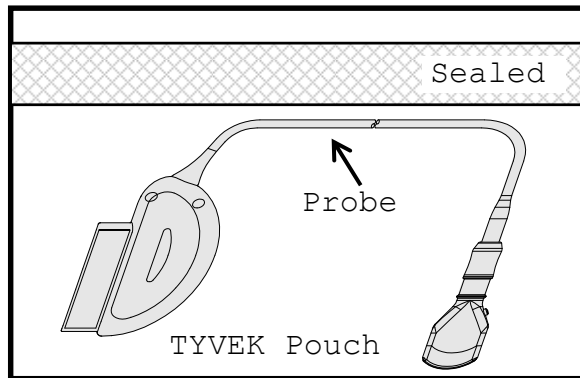

Fig. 5 Sealing

- 3) Put the sealed pouch into a tray or plastic mesh wire for sterilization.

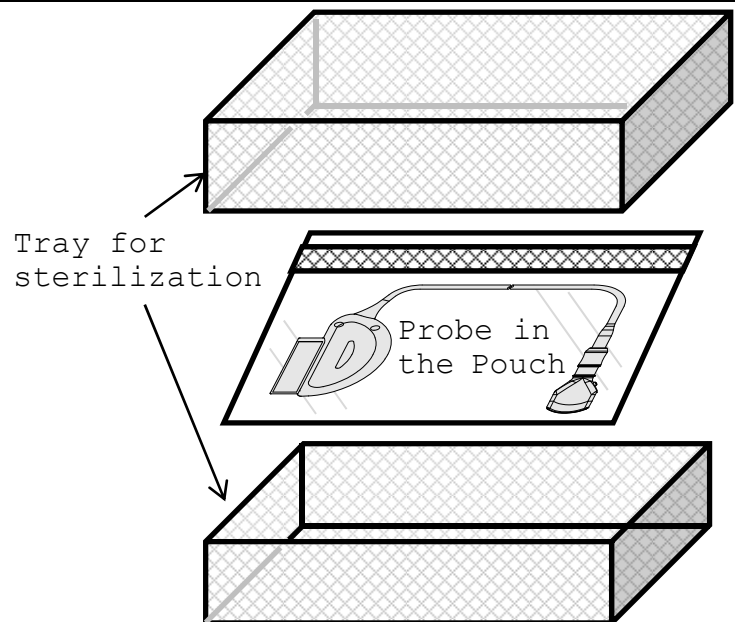

Fig. 6 Packaging in a tray

4.8 Storage



Store the equipment in a cool, dustproof, dry, and dark space to avoid high temperature, humidity and direct sunlight. Limitations for the time for sterilized equipment belong to package.

5. Maintenance and Safety Inspection



- 1) After using the probe, the probe should be cleaned and disinfected or sterilized according to "4. Reprocessing Procedure", store the probe in a cool and dark space to avoid high temperature, humidity and direct sunlight.
- 2) Visually inspect the surface of the probe head, the housing, the cable and the connector for any crack, scratch or denaturalization. If you find any damage, do not use the probe, and immediately contact a service support.

6. Safety Precautions

WARNING

- Never use the probe if the probe head, housing or cable are cracked or damaged.
- Warning is case of using probe covers which latex is contained to. The latex may cause such allergic reactions as itching, rubor, urticaria, swelling, fever, anhelation, wheezing, and depression of blood pressure, shock and so on. For the patients suspected of latex allergy, do not use the latex-containing medical devices. If you observe any of above mentioned symptoms in your patient during the operation, stop the use of the latex-containing medical devices immediately and take an appropriate treatment to the patient.

CAUTION

- By examination of an early pregnancy the exposure time shall be as short as possible. Start examination with acoustic output power set to L (Low).
- Do not expose the connector to water or other liquids. The connector is not waterproof.
- Do not hit or drop the probe. The probe is easily damaged by mechanical shock.
- Do not use detergents and disinfectants other than listed in "7.2 Suppliers list".
- Use a sterile probe cover to avoid staining or damaging the acoustic lens.
- Clean and sterilize the probe before the first use as it is not sterilized in the factory.
- Use only the soft cloth or tissue to clean the acoustic lens.
- A biopsy should be performed only by a well-trained physician.
- Do not attach unapproved devices to the probe.

7. Specifications

7.1 Probe

Type:	C42K Probe
Acoustic working frequency:	7.5MHz
Technology:	Convex Array Probe
Dimensions:	See Fig. 7.
Weight:	Approx. 0.56kg (incl. cable and connector)
Scanning angle:	65°
Probe materials:	Bio-compatible allergy free components
Acoustic output:	According to IEC60601-2-37 (See Main Unit manual.)
Applicable system:	Depending on production and upgrade status. For detailed information contact a service support.
Classification:	MDD classification IIa.
Cleaning:	Applicable detergents are listed in the suppliers list
Disinfection:	Applicable disinfectants are listed in the suppliers list
Sterilization:	ETO gas sterilization, Plasma sterilization
Operating conditions:	
Ambient temperature;	+10 - +35°C
Contact surface temperature (temperature of examinee) ;	max. 42°C
Relative humidity;	30 - 85%
Storage conditions:	
Temperature;	-10 - +55°C
Relative humidity;	10 - 95% (subject to no condensation)

7.2 Suppliers List

The products listed below are seriously tested and approved for use with C42K Probe.

Product name	Manufacturer	Purpose
CIDEZYME®	Johnson & Johnson	Enzymatic detergent /cleaner
Cidex® OPA	Johnson & Johnson	Disinfectant
HYAMINE SOLUTION	RICCA CHEMICAL COMPANY	Disinfectant
STERIHYDE®	Maruishi Pharmaceutical	Disinfectant

Please contact your local distributor for a current version of the "Disinfectant/Sterilization Method Compatibility for Ultrasound Probe and Accessory List".

8. Disposal of the probe

Recycle or dispose of this equipment properly in compliance with the Waste Management and Public Cleansing Law.

CAUTION

Before disposing of the equipment, disinfect or take other infection-prevention measures.

Disposal of the equipment without taking the proper preventative measures can lead to infection.

Waste Electrical and Electronic Equipment (WEEE) Directive

The illustration on the right is required by the EU WEEE Directive to appear on all electrical and electronic equipment.

For proper disposal of this product in an EU nation, contact an EU office or agency and observe appropriate local and national regulations and laws.



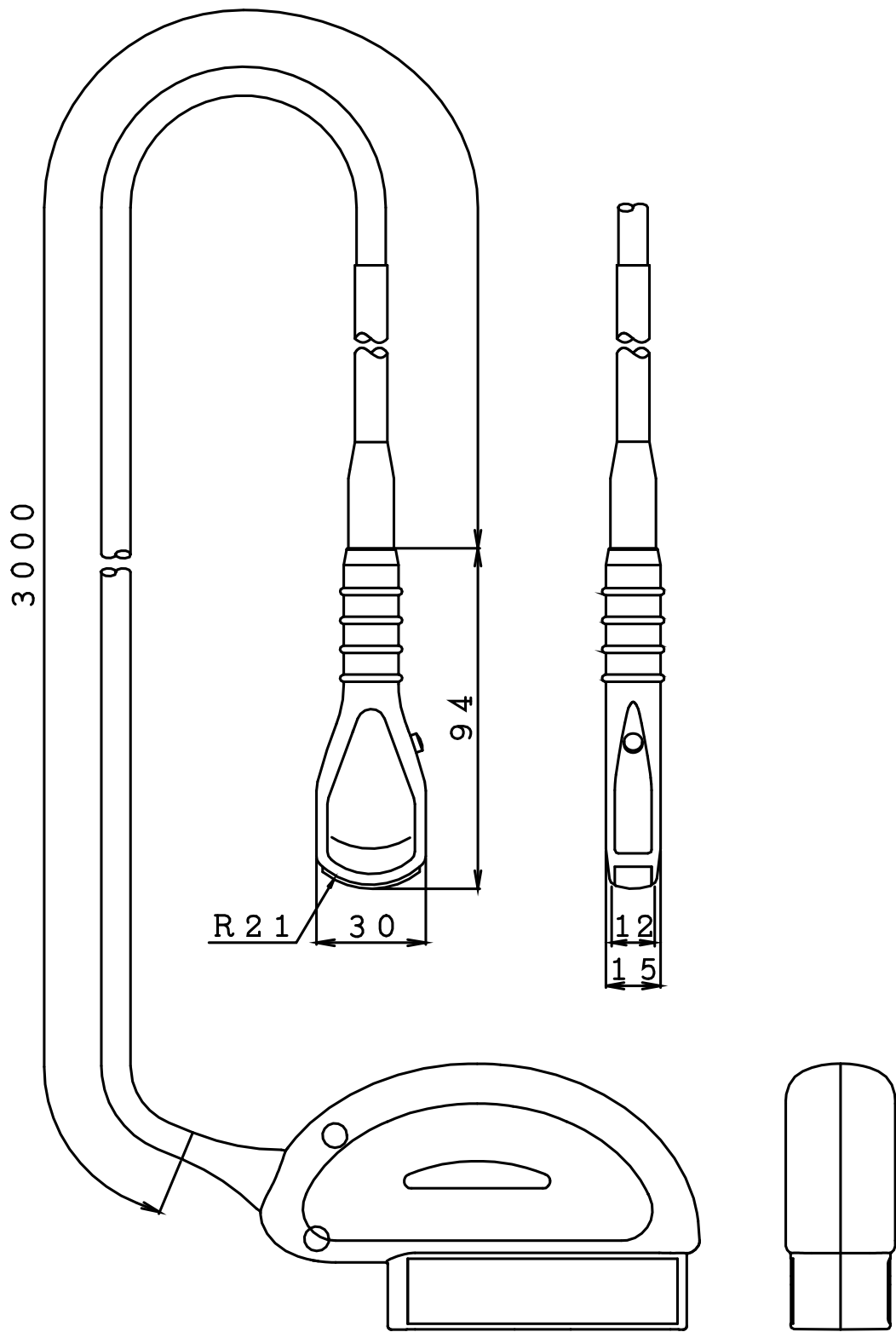

Fig. 7 Dimensions

Unit: mm

